

SPECIFICATION

MODEL : SLHNNWH629T1S0Q2T2

[Rank : $V_f(S1, S2)$, CIE(Q0, R0) $\Phi_v(T1, U1)$]

HIGH POWER LED – SUNNIX6

CUSTOMER		
CHECKED	CHECKED	APPROVED
Preliminary		

SAMSUNG LED			
DRAWN	CHECKED(Sales)	CHECKED(Quality)	APPROVED

SAMSUNG LED CO.,LTD.
314, MAETAN3-DONG, YEONGTONG-GU,
SUWON-SI, GYEONGGI-DO, KOREA, 443-743

Contents

1.	Product outline	3
2.	Absolute Maximum Rating	3
3.	Characteristics	3
4.	Chromaticity Diagram	4
5.	Typical Characteristic Graphs	5
6.	Outline Drawing and Dimension	6
7.	Package Structure	7
8.	Solder Conditions	7
9.	Reliability Test Items and Conditions	8
10.	Taping Dimension	9
11.	Label Structure	10
12.	Lot Number	10
13.	Reel Packing Structure	11
14.	Precaution for Use	13
15.	Hazard Substance Analysis	18
16.	Revision History	22

1. Product Outline

1) Features

- Plastic Molded Lead Frame Type : 8.0 mm, 8.0 mm, 3.9 mm
- High CRI LED
- Built In 9 LED Chips
- Beam View Angle($\Delta\theta$) : 120 °
- Lead(Pb) Free Product : RoHS Compliant

2) Applications

- General Illumination
- Down Lighting
- Decorative Lighting

2. Absolute Maximum Rating

- Operation Forward Current 250 mA
- Peak Pulsed Forward Current 350 mA
- Reverse Voltage 16.5 V
- Thermal Resistance ($R_{th\ J-S}$) $\cong 5\text{ }^{\circ}\text{C/W}$
- Operating Temperature Range (T_{OPR}) $-40\text{ }^{\circ}\text{C} \sim 85\text{ }^{\circ}\text{C}$
- Storage Temperature Range (T_{STG}) $-40\text{ }^{\circ}\text{C} \sim 110\text{ }^{\circ}\text{C}$
- LED Junction Temperature (T_J) 120 °C

3. Characteristics

1) Electrical properties ($T_a = 25\text{ }^{\circ}\text{C}$)

Parameter	Symbol	Condition	Rank	Min.	Typ.	Max.	Unit	
Reverse Voltage	V_R	$I_F = 5\text{ mA}$	–	12.0	–	16.5	V	
Forward Voltage	V_F	$I_F = 180\text{ mA}$	S0	S1	8.9	–	10.0	V
				S2	10.0	–	11.0	

2) Luminous Flux ($T_a = 25\text{ }^{\circ}\text{C}$)

Rank		Symbol	Condition	Min.	Typ.	Max.	Unit
T2	T1	Φ_V	$I_F = 180\text{ mA}$	110	–	130	lm
	U1			130	–	150	

3) Chromaticity Coordinates ($T_a = 25 \text{ }^\circ\text{C}$)

Rank		CCT(K)	Condition	CCx				CCy			
Q2	Q0	6000~7000	$I_F = 180 \text{ mA}$	0.3128	0.3250	0.3200	0.3011	0.2864	0.2981	0.3600	0.3407
	R0	5000~6000		0.3250	0.3428	0.3484	0.3200	0.2981	0.3138	0.3885	0.3600

※ Tolerance : $V_F : \pm 0.1$, $\Phi_V : \pm 10 \%$, CCx CCy : ± 0.02

※ Luminous Flux (1W) : Typ. 80 lm/W (@120 mA)

※ Color Rendering Index (Ra) : Typ. 87

4. Chromaticity Diagram

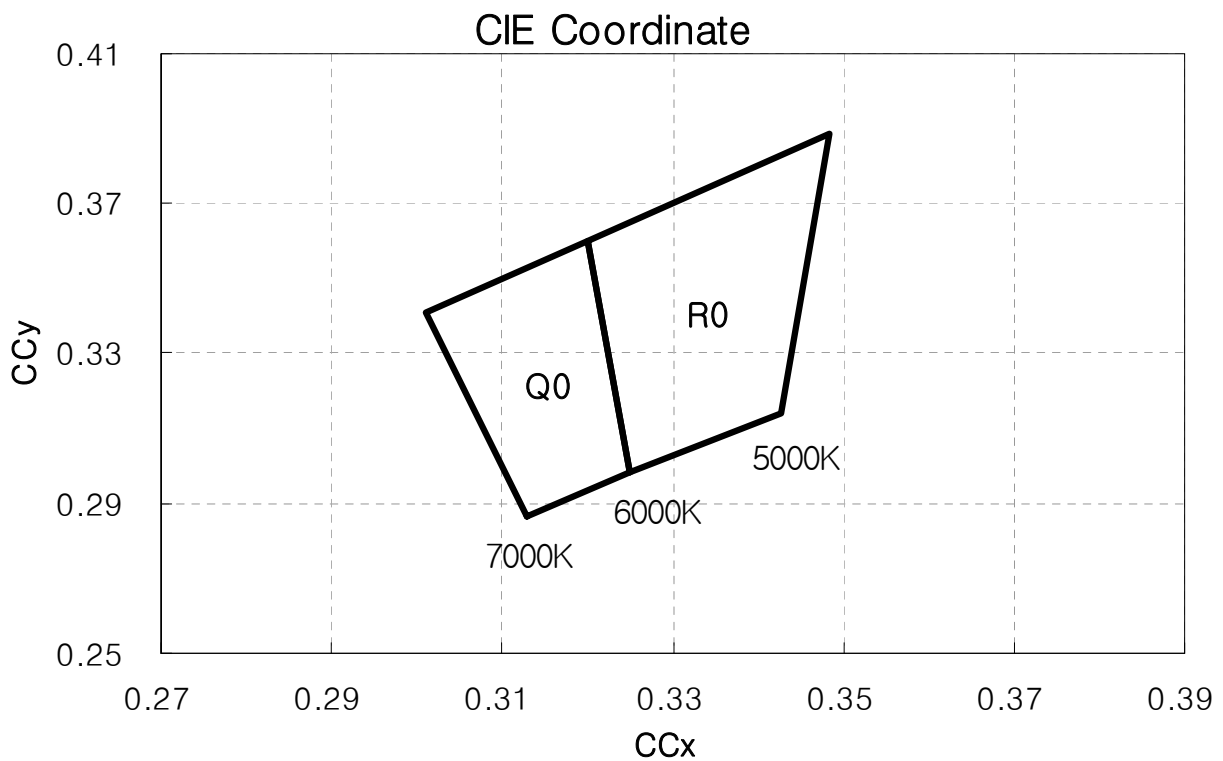

Approved Rank

Symbol	V_F	CIE	Φ_V
Rank	S1, S2	Q0, R0	T1, U1

5. Typical Characteristic Graphs

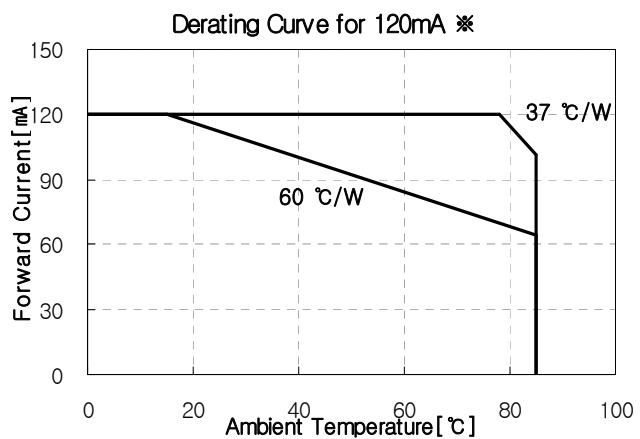
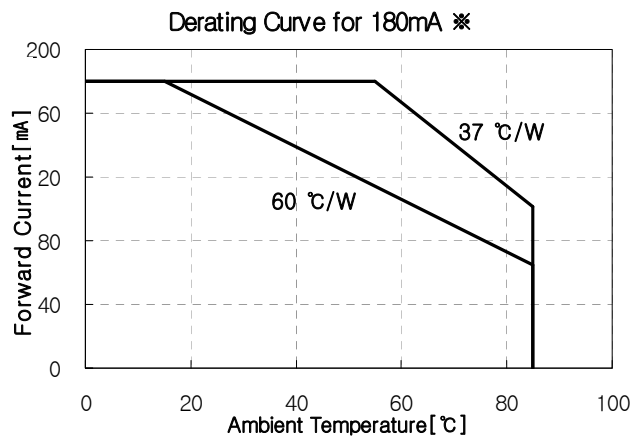
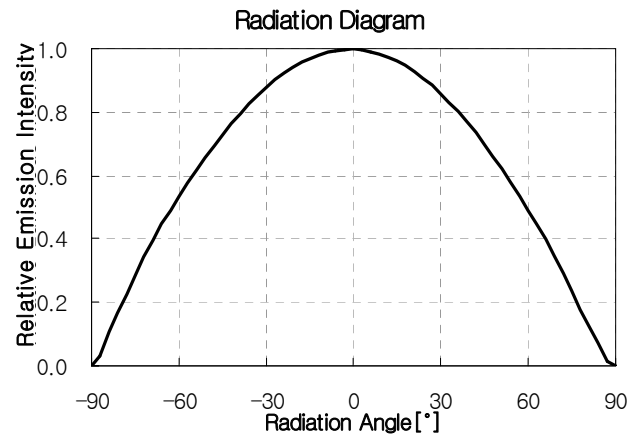
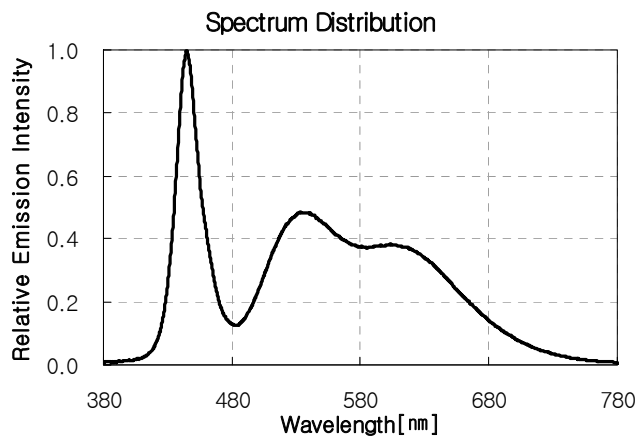
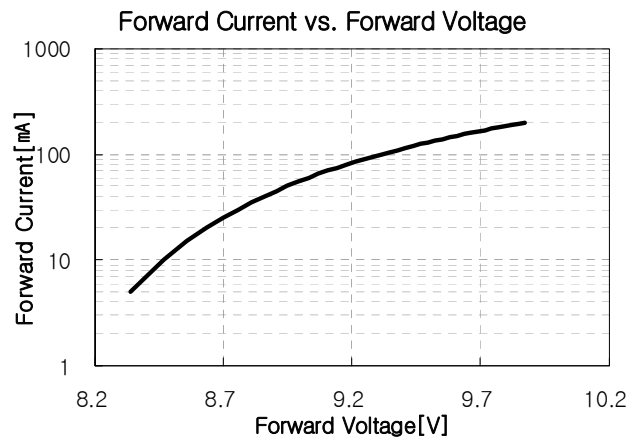
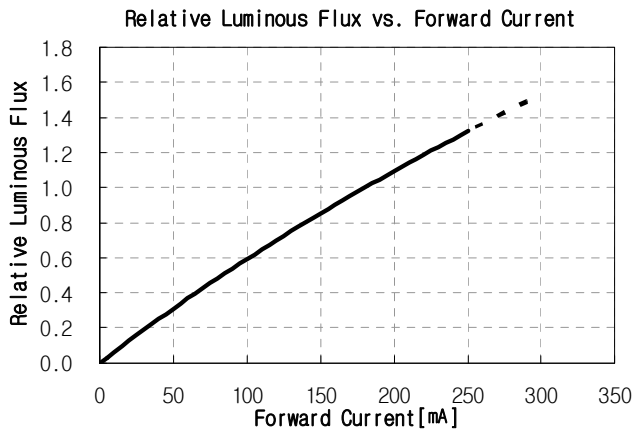

※ Thermal Resistance Test Conditions

- Junction to ambient thermal resistance
- JEDEC Standard JESD 51-2,3

JESD 51-2 : Integrated Circuits Thermal Test Method Environmental Conditions
 - Natural Convection (Still Air)

JESD 51-3 : Low Effective Thermal Conductivity Test Board for Leaded Surface Mount Package

6. Outline Drawing and Dimension

Unit : mm
Tolerance : ± 0.2

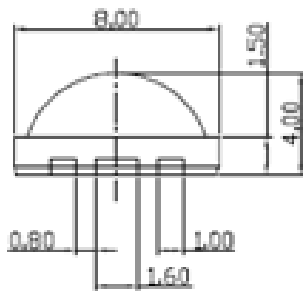
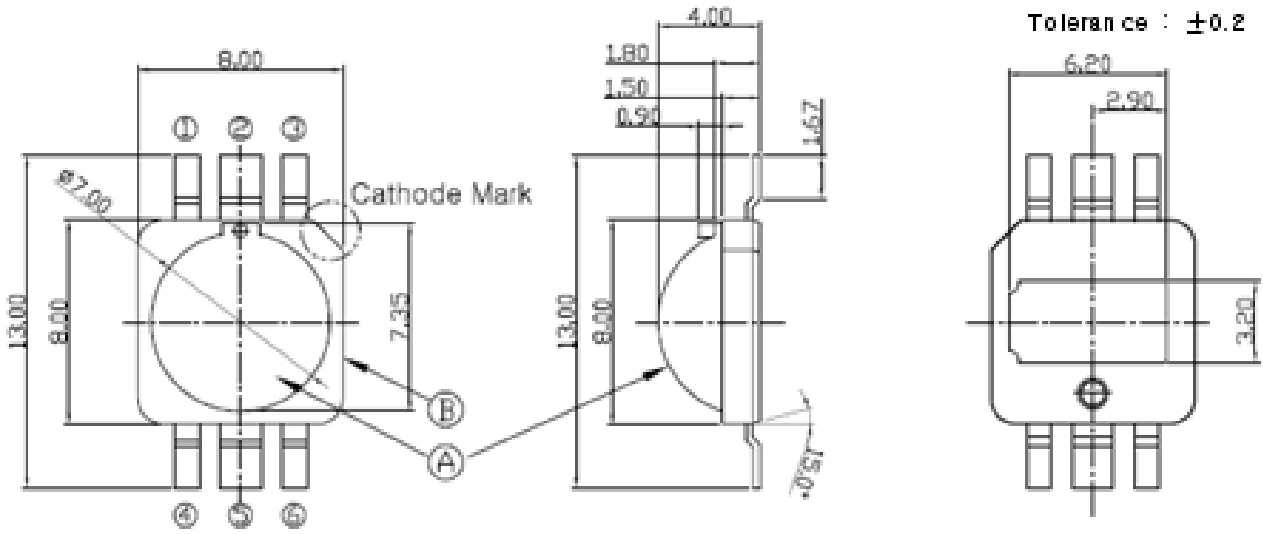

Pick and Place

1. Do not place pressure on the encapsulating resin ('A')
2. The maximum compressing force is 15N on the polymer ('B')

Circuit

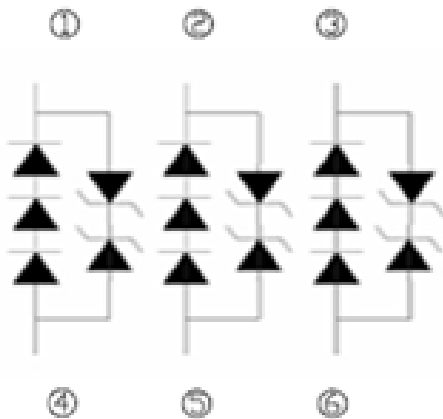

Solder Pattern for Surface Mount

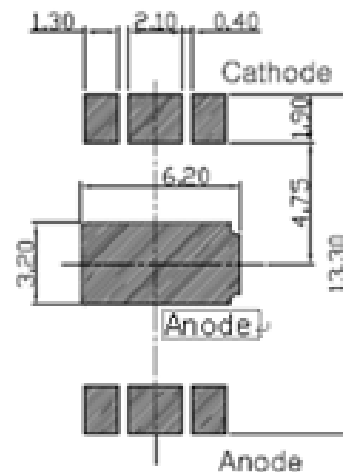

Remarks

Make sure that the heat sink is electrically connected to the Anode.
Heat sink is to be soldered, If not, use the heat conductive adhesive.

7. Package Structure

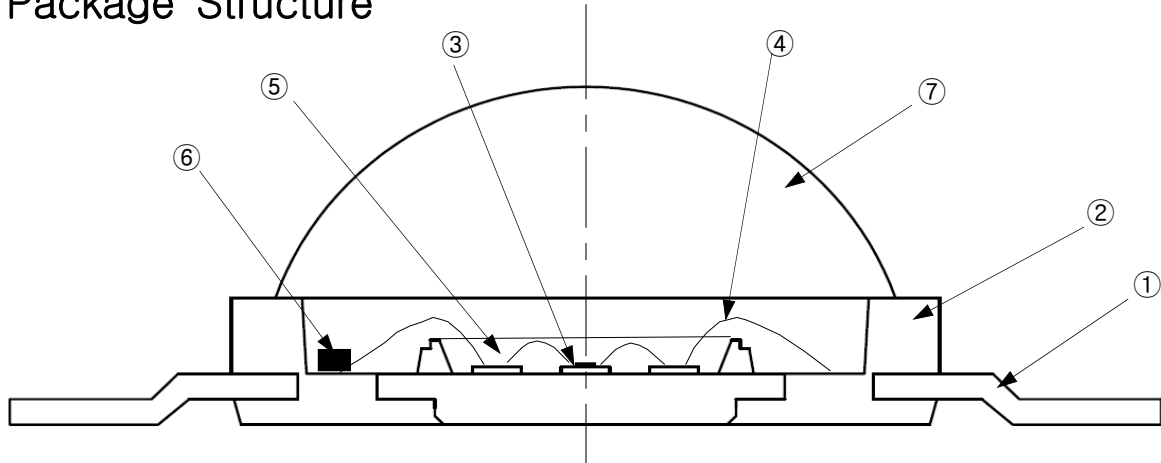

No	Component	Material
①	Frame	Copper frame(Silver plated)
②	Package	Heat-resistant polymer
③	LED chip	GaN/Al ₂ O ₃
④	Wire	Gold wire
⑤	Encapsulant	Silicone + Phosphor
⑥	Zener diode	Si
⑦	Lens	Silicone

8. Solder Conditions

1) Reflow Conditions (Pb-Free)

Reflow Frequency : 2 time max.

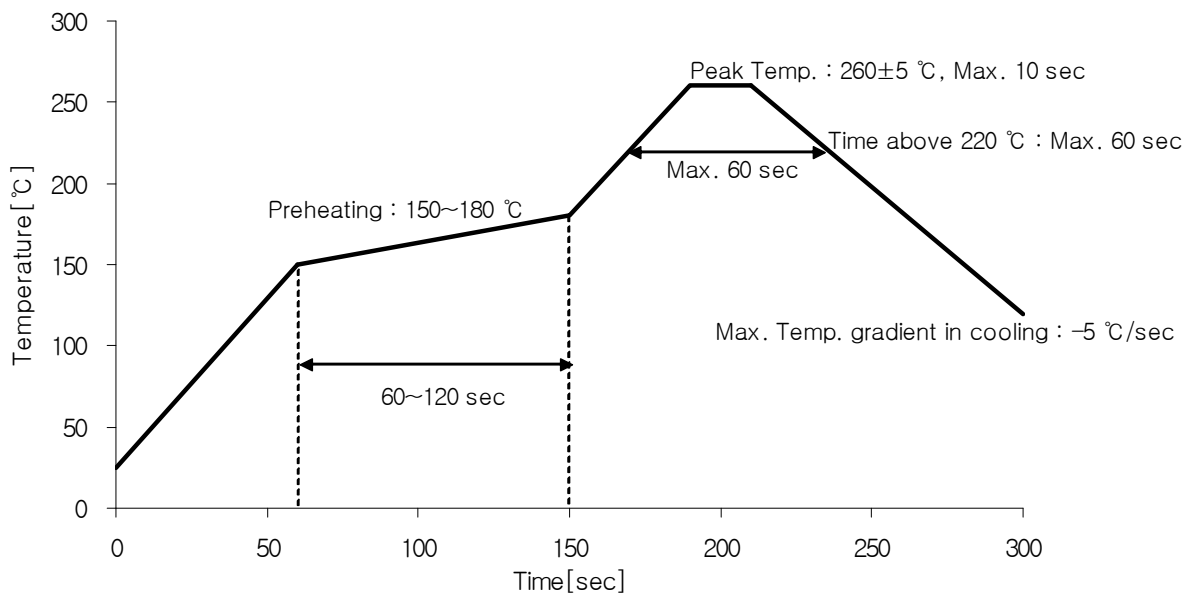

2) For Manual Soldering

Not more than 5 seconds @Max. 300 °C, under soldering iron.

9. Reliability Test Items and Conditions

1) Test Items

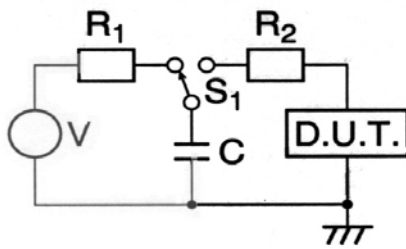
Test Items	Test Conditions	Test Hours/Cycles
Room Temperature life test	25 °C, $I_F = \text{Max DC}^*$	1,000 h
High Temperature humidity life test	85 °C, 60 % RH, $I_F = \text{Max DC}^*$	1,000 h
High Temperature life test	85 °C, $I_F = \text{Max DC}^*$	1,000 h
Low Temperature life test	-40 °C, $I_F = \text{Max DC}^*$	1,000 h
High Temperature Storage	110 °C	1,000 h
Low Temperature Storage	-40 °C	1,000 h
Thermal Shock	-40 / 120 °C, each 30 min	200 cycles
Temperature humidity Cycle On/Off test	-40 / 85 °C, each 20 min, 100 min transfer Power On/off each 5 min, DC 180 mA	100 cycles
Reflow (Pb-Free)	Peak 260±5 °C for 10 sec	3 times
ESD(HBM)	 <p>R1 : 10 MΩ , R2 : 1.5 kΩ , C : 100 pF</p>	3 times (± 5 kV)

* Max. DC current is depending on maximum current derating curve.

2) Criteria for Judging the Damage

Item	Symbol	Test Condition	Limit	
			Min	Max
Forward Voltage	V_F	$I_F = 180 \text{ mA}$	-	U.S.L.*1.2
Luminous Flux	Φ_V	$I_F = 180 \text{ mA}$	L.S.L.*0.5	-
Reverse Voltage	V_R	$I_R = 5 \text{ mA}$	-	U.S.L.*2.0

* U.S.L : Upper Standard Level, L.S.L : Lower Standard Level

10. Taping Dimension

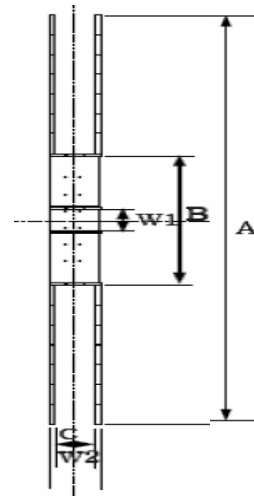
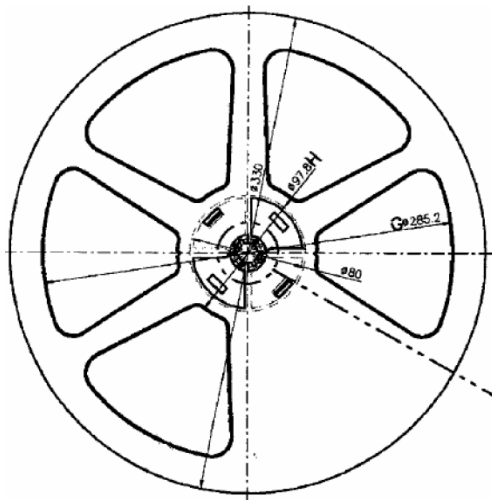
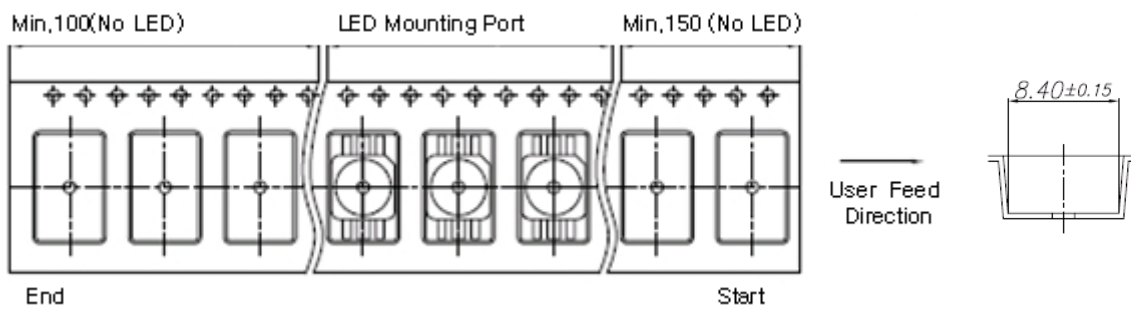
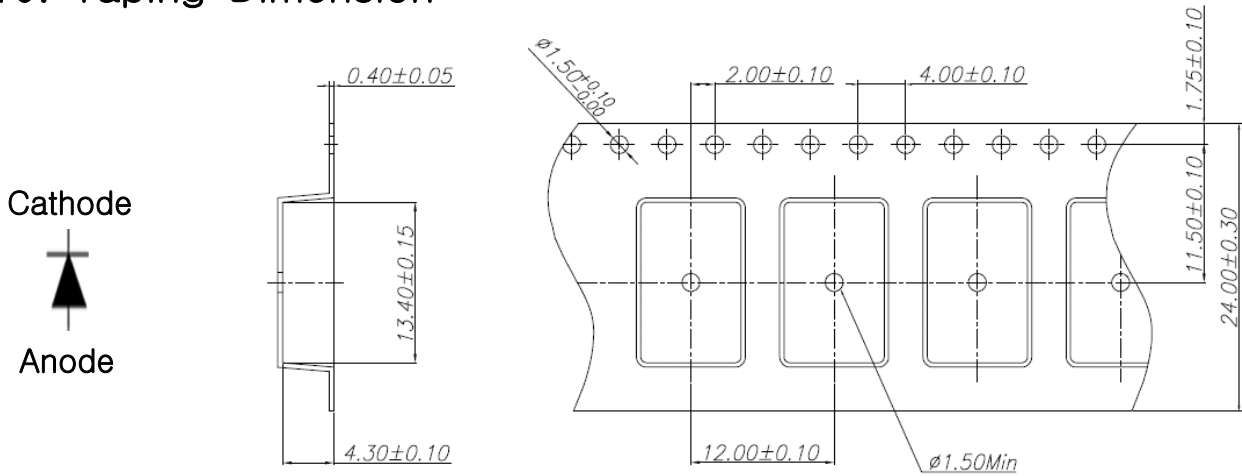

Symbol	A	B	C	W1	W2
Dimension(mm)	330 ± 1	80 ± 1	25 ± 0.5	13 ± 0.3	29.5 ± 1

- (1) Quantity : 1,000 Pcs / 13" Reel.
- (2) Cumulative Tolerance : Cumulative Tolerance/10 pitches is less than ±0.2 mm
- (3) Adhesion Strength of Cover Tape : Adhesion strength to be 0.1–0.7N when the cover tape is turned off from the carrier tape at 10 °C angle to be the carrier tape.
- (4) Packaging : P/N, Manufacturing data Code No. and quantity to be indicated on a damp proof Package

11. Label Structure



Rank Code

/S1/ : VF Rank (refer to page 3)

/R0/ : Chromaticity Coordinate Rank, CIE (refer to page 4)

/T1/ : Luminous Flux (refer to page 3)

12. Lot Number

The Lot number is composed of the following characters

●◎◇◆□■△△△ / |▲▲▲ / 1000PCS

● : Production Site (S:SEMCO, G:Gosin China, L:SOLLEDS)

◎ : L (LED)

◇ : Product State (A:Normality, B:Bulk, C:First Production, R:Reproduction, S:Sample)

◆ : Year (S:2008, T:2009, U:2010...)

□ : Month (1 ~ 9, A, B)

■ : Day (1 ~ 9, A, B ~ V)

△ : SEMCO. Product number (1 ~ 999)

▲ : Reel Number (1 ~ 999)

13. Reel Packing Structure

1) Reel

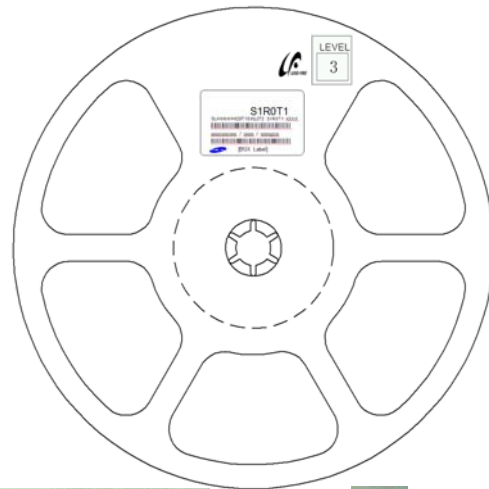

2) Aluminum Bag

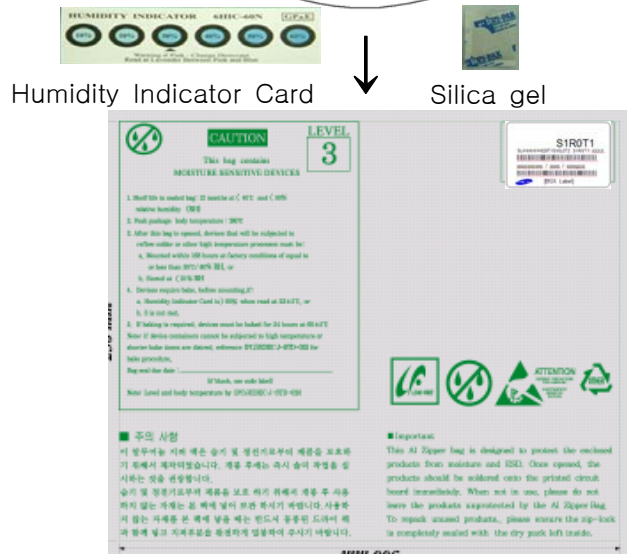

3) Inner Box

Material : Paper(SW3B(B))

TYPE	SIZE(mm)		
	L	W	H
13inch	335	45	335

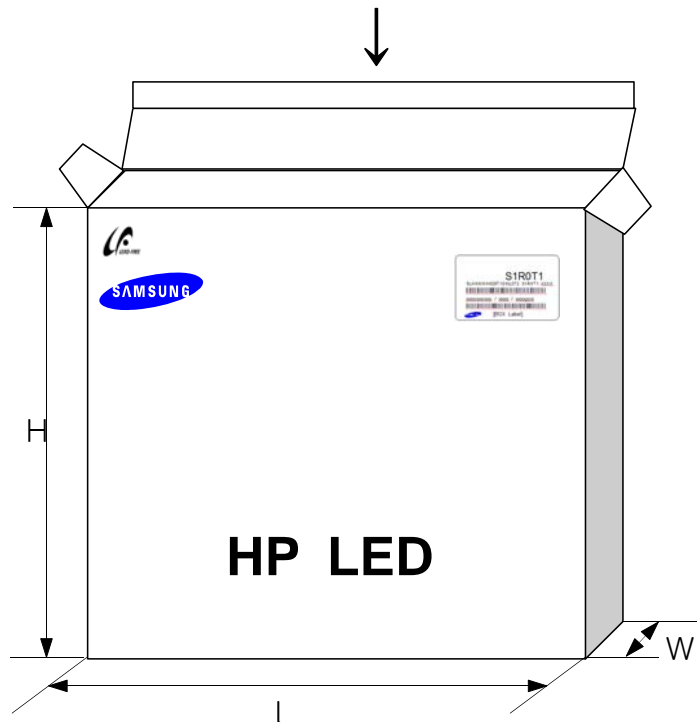
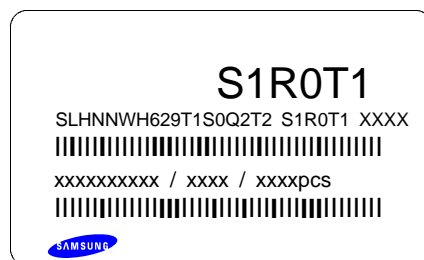

4) Carton Box

Material : Paper(SW3B(B))

TYPE	SIZE(mm)		
	L	W	H
13inch	350	350	350

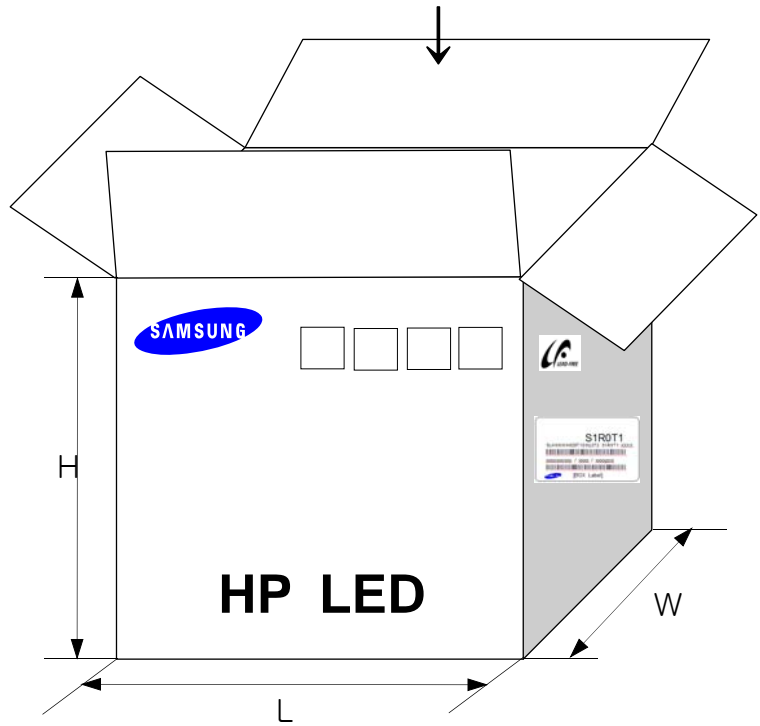
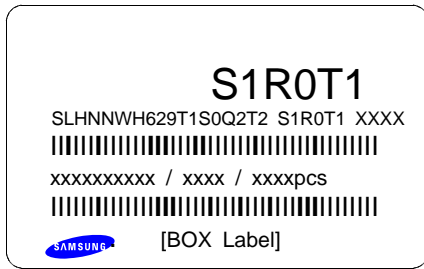

14. Precaution for Use

- 1) For over-current-proof function, customers are recommended to apply resistors to prevent sudden change of the current caused by slight shift of the voltage.
- 2) This device should not be used in any type of fluid such as water, oil, organic solvent, etc. When washing is required, IPA is recommended to use.
- 3) When the LEDs illuminate, operating current should be decided after considering the ambient maximum temperature.
- 4) LEDs must be stored in a clean environment.
If the LEDs are to be stored for 3 months or more after being shipped from SEMCO, they should be packed by a sealed container with nitrogen gas injected. (Shelf life of sealed bags : 12 months, temp. 0~40°C, 20~70%RH)
- 5) After storage bag is open, device subjected to soldering, solder reflow, or other high temperature processes must be:
 - a. Mounted within 168 hours (7days) at an assembly line with a condition of no more than 30°C/60%RH,
 - b. Stored at <10% RH.
- 6) Repack unused Products with anti-moisture packing, fold to close any opening and then store in a dry place.
- 7) Devices require baking before mounting, if humidity card reading is >60% at 23±5°C.
- 8) Devices must be baked for 24hours at 65±5°C, if baking is required.
- 9) The LEDs are sensitive to the static electricity and surge. It is recommended to use a wrist band or anti-electrostatic glove when handling the LEDs.
If voltage exceeding the absolute maximum rating is applied to LEDs, it may cause damage or even destruction to LED devices.
Damaged LEDs may show some unusual characteristics such as increase in leak current, lowered turn-on voltage, or abnormal lighting of LEDs at low current.

14. Precaution for Use (취급상 주의사항)

- 1) For over-current-proof function, customers are recommended to apply resistors to prevent sudden change of the current caused by slight shift of the voltage.
과전류 방지를 위해 전압의 미세한 이동에 의해 야기되는 전류의 순간 변화를 방지하기 위해 저항 등의 설치를 권장함.
- 2) This device should not be used in any type of fluid such as water, oil, organic solvent, etc. When washing is required, IPA is recommended to use.
제품은 물, 오일, 유기물과 같은 액체 타입에서의 사용은 제한되며, 세정이 필요할 시에는 IPA 사용을 권장함.
- 3) When the LEDs illuminate, operating current should be decided after considering the ambient maximum temperature.
LED의 발광 시, 동작 전류는 주변 최고온도를 고려하여 결정되어야 함.
- 4) LEDs must be stored in a clean environment.
If the LEDs are to be stored for 3 months or more after being shipped from SEMCO, they should be packed by a sealed container with nitrogen gas injected. (Shelf life of sealed bags : 12 months, temp. 0~40°C, 20~70%RH)
LED의 보관은 청정한 환경에서 보존되어야 하며, 만약 삼성전기로부터 공급받는 후 3개월 또는 그 이상 보관이 필요하다면 질소 가스를 동봉한 보존용기에 보관되어야 함. (보존 bag의 수명 : 12 개월, 보존 온도 0~40°C, 습도 20~70%RH)
- 5) After storage bag is open, device subjected to soldering, solder reflow, or other high temperature processes must be:
보존 Bag이 개봉된 후에, 납땀이나 reflow등의 높은 온도에 노출되는 제품은 다음의 사항에 부합되어야 함.
 - a. Mounted within 168 hours (7days) at an assembly line with a condition of no more than 30°C/60%RH,
a. 제품은 30°C/60%RH보다 같거나 낮은 조립조건에서 168시간(7일) 이내에 조립되어야 함.
 - b. Stored at <10% RH.
b. 10% 이하의 상대습도에서 보관되어야 함.
- 6) Repack unused Products with anti-moisture packing, fold to close any opening and then store in a dry place.
사용하지 않은 제품은 방습팩에 넣어 개봉 부위를 닫아서 다시 포장한 후, 건조한

장소에서 보관할 것을 권장함

- 7) Devices require baking before mounting, if humidity card reading is $>60\%$ at $23\pm 5^{\circ}\text{C}$.
 만약 습도표시카드의 수치가 $23\pm 5^{\circ}\text{C}$ 에서 60% 이상이라면, 제품 실장 전에 baking하여야 함.
- 8) Devices must be baked for 24hours at $65\pm 5^{\circ}\text{C}$, if baking is required.
 만약 baking이 필요하다면, 제품은 $65\pm 5^{\circ}\text{C}$ 에서 24시간 정도 baking 되어야 함.
- 9) The LEDs are sensitive to the static electricity and surge. It is recommended to use a wrist band or anti-electrostatic glove when handling the LEDs.
 LED는 정전기 및 서지에 민감한 제품이므로, LED 제품을 다룰 시에는 정전기 방지장갑이나 손목밴드를 사용하기를 권장함.
 If voltage exceeding the absolute maximum rating is applied to LEDs, it may cause damage or even destruction to LED devices.
 만약 절대 허용치를 초과하는 전압이 LED에 가해지면, LED 소자는 파괴되거나 손상될 수 있음.
 Damaged LEDs may show some unusual characteristics such as increase in leak current, lowered turn-on voltage, or abnormal lighting of LEDs at low current.
 손상된 제품은 누설전류의 증가, Turn on 전압의 저하, 저 전류에서의 점등불량 등의 이상 거동을 보일 수 있음.

14. Precaution for Use

- 1) For over-current-proof function, customers are recommended to apply resistors to prevent sudden change of the current caused by slight shift of the voltage.

電圧の少しの変更により引き起こされる突然の電流変更を防ぐために過電流防止機能の抵抗器を適用するように勧めします。

- 2) This device should not be used in any type of fluid such as water, oil, organic solvent, etc. When washing is required, IPA is recommended to use. 本製品は、水、油、有機的な溶剤などの任意のタイプの流体の中で使用しないで下さい。洗浄が要求される場合、IPAを使用して下さい。

- 3) When the LEDs illuminate, operating current should be decided after considering the ambient maximum temperature.

LED発光の時、動作電流はLED周囲の温度条件により使用電流を決めてください。

- 4) LEDs must be stored in a clean environment.

If the LEDs are to be stored for 3 months or more after being shipped from SEMCO, they should be packed by a sealed container with nitrogen gas injected. (Shelf life of sealed bags : 12 months, temp. 0~40°C, 20~70%RH) 本製品は清潔な大気を維持する環境で保存して下さい。

LEDが送られた後に3か月以上保存される場合、窒素雰囲気を用意した密閉したコンテナ装置に保管して下さい。

(0~40°C以下、20~70%のRH以下とし12か月以内)

- 5) After storage bag is open, device subjected to soldering, solder reflow, or other high temperature processes must be:

開封後、Reflowハンダあるいは他の高温プロセスにさらされる場合は、

a. Mounted within 168 hours (7days) at an assembly line with a condition of no more than 30°C/60%RH,

a. 工場条件30°C/60%以下以下の条件で168時間（7日）以内にマウントを完了して下さい。

b. Stored at <10% RH.

b. また10%のRHで保存して下さい。

- 6) Repack unused Products with anti-moisture packing, fold to close any opening and then store in a dry place.

未使用のLEDが残った場合は、乾燥剤（シリカゲル）入り乾燥容器などで保管して下さい。なお当社防湿袋に戻し、再封印することを推奨します。

7) Devices require baking before mounting, if humidity card reading is $>60\%$ at $23\pm 5^{\circ}\text{C}$.

以下の場合、マウントする前にbakeすることをお勧めします。

$23\pm 5^{\circ}\text{C}$ での湿度カードの表紙が60%以上の時

8) Devices must be baked for 24hours at $65\pm 5^{\circ}\text{C}$, if baking is required.

Bakingが要求される場合、 $65\pm 5^{\circ}\text{C}$ で24時間Bakeすることをお勧めします。

9) The LEDs are sensitive to the static electricity and surge. It is recommended to use a wrist band or anti-electrostatic glove when handling the LEDs.

本製品は静電気やサージ電圧に敏感で、素子の損傷や信頼性低下を起こすことがあります。本LEDの取り扱いに際しては、手首バンドまたは静電気防止グローブ等の静電気対策を十分行って下さい

If voltage exceeding the absolute maximum rating is applied to LEDs, it may cause damage or even destruction to LED devices.

LEDに最大定格電圧値を超過される場合、LEDの損害を引き起こし、破壊する可能性があります。

Damaged LEDs may show some unusual characteristics such as increase in leak current, lowered turn-on voltage, or abnormal lighting of LEDs at low current.

損傷したLEDには、漏洩電流が著しく大きくなり、順方向の立ち上がり電圧が低下したり低電流で発光しなくなる等の異常が現れます。

15. Hazard Substance Analysis



Test Report No. F690501/LF-CTSAYAA09-20354

Issued Date: July 17, 2009

Page 1 of 4

To: **SAMSUNG LED CO.,LTD.**
 314, Maetan-dong
 Yeongtong-gu
 Suwon-city
 GYEONGGI-DO
 Korea

The following merchandise was submitted and identified by the client as :

Product Name : LED
SGS File No. : AYAA09-20354
Received Date : July 14, 2009
Test Performing Date : July 15, 2009
Test Performed : SGS Testing Korea tested the sample(s) selected by applicant with following results
Test Results : For further details, please refer to following page(s)
Comments : By the applicant's specific request, the sampling and testing was performed only for the part indicated in the photo without disassembly. The client has confirmed that the described item No.s/part No.s are the same with the sample submitted.

Pluto Kim
 Cindy Park
 Jinee Song/ Testing Person

SGS Testing Korea Co. Ltd.

Jeff Jang / Chemical Lab Mgr

This document is issued by the Company subject to its General Conditions of Service placed on file, available on request on www.sgs.com and, for electronic format documents, subject to Terms and Conditions for Electronic Documents at www.sgs.com/secure/electronic_documents.
 Attention is drawn to the limitation of SCOPE, interpretation and jurisdiction herein defined therein. Any holder of this document is advised that information contained therein reflects the Company's findings at the time of its intervention only and shall be void of Client's responsibility if any. The Company's sole responsibility is to its Client and this document does not constitute grounds for a conclusion from monitoring all their rights and obligations under the applicable documents. This document cannot be reproduced except in full, without prior written approval of the Company. Any unauthorized alteration, forgery or falsification of the content or appearance of this document is unlawful and offenders may be prosecuted to the fullest extent of the law.
 Unless otherwise stated the results shown in this and report refer only to the sample(s) tested and such sample(s) are retained for 180 days only.



Test Report No. F690501/LF-CTSAYAA09-20354

Issued Date: July 17, 2009

Page 2 of 4

Sample No. : AYAA09-20354.001
 Sample Description : LED
 Item No./Part No. : SLHNNWW629T1(SLHNNWH629T)

Heavy Metals

Test Items	Unit	Test Method	MDL	Results
Cadmium (Cd)	mg/kg	With reference to IEC 62321:2008, ICP	0.5	N.D.
Lead (Pb)	mg/kg	With reference to IEC 62321:2008, ICP	5	N.D.
Mercury (Hg)	mg/kg	With reference to IEC 62321:2008, ICP	2	N.D.
Hexavalent Chromium (Cr VI)	mg/kg	With reference to IEC 62321:2008, UV-VIS	1	N.D.

Flame Retardants-PBBs/PBDEs

Test Items	Unit	Test Method	MDL	Results
Monobromobiphenyl	mg/kg	With reference to IEC 62321:2008, GC-MS	5	N.D.
Dibromobiphenyl	mg/kg	With reference to IEC 62321:2008, GC-MS	5	N.D.
Tribromobiphenyl	mg/kg	With reference to IEC 62321:2008, GC-MS	5	N.D.
Tetrabromobiphenyl	mg/kg	With reference to IEC 62321:2008, GC-MS	5	N.D.
Pentabromobiphenyl	mg/kg	With reference to IEC 62321:2008, GC-MS	5	N.D.
Hexabromobiphenyl	mg/kg	With reference to IEC 62321:2008, GC-MS	5	N.D.
Heptabromobiphenyl	mg/kg	With reference to IEC 62321:2008, GC-MS	5	N.D.
Octabromobiphenyl	mg/kg	With reference to IEC 62321:2008, GC-MS	5	N.D.
Nonabromobiphenyl	mg/kg	With reference to IEC 62321:2008, GC-MS	5	N.D.
Decabromobiphenyl	mg/kg	With reference to IEC 62321:2008, GC-MS	5	N.D.
Monobromodiphenyl ether	mg/kg	With reference to IEC 62321:2008, GC-MS	5	N.D.
Dibromodiphenyl ether	mg/kg	With reference to IEC 62321:2008, GC-MS	5	N.D.
Tribromodiphenyl ether	mg/kg	With reference to IEC 62321:2008, GC-MS	5	N.D.
Tetrabromodiphenyl ether	mg/kg	With reference to IEC 62321:2008, GC-MS	5	N.D.
Pentabromodiphenyl ether	mg/kg	With reference to IEC 62321:2008, GC-MS	5	N.D.
Hexabromodiphenyl ether	mg/kg	With reference to IEC 62321:2008, GC-MS	5	N.D.
Heptabromodiphenyl ether	mg/kg	With reference to IEC 62321:2008, GC-MS	5	N.D.
Octabromodiphenyl ether	mg/kg	With reference to IEC 62321:2008, GC-MS	5	N.D.
Nonabromodiphenyl ether	mg/kg	With reference to IEC 62321:2008, GC-MS	5	N.D.
Decabromodiphenyl ether	mg/kg	With reference to IEC 62321:2008, GC-MS	5	N.D.

NOTE: (1) N.D. = Not detected.(<MDL)
 (2) mg/kg = ppm
 (3) MDL = Method Detection Limit
 (4) - = No regulation
 (5) ** = Qualitative analysis (No Unit)
 (6) * = Boiling-water-extraction:
 Negative = Absence of CrVI coating
 Positive = Presence of CrVI coating; the detected concentration in boiling-water-extraction solution is equal or greater than 0.02 mg/kg with 50 cm2 sample surface area.

This document is issued by the Company subject to its General Conditions of Service printed herewith, in addition to request or acceptance of www.sgs.com and www.kor.sgs.com and, for electronic format documents, subject to Terms and Conditions for Electronic Documents at www.sgs.com.
 Member is liable to the holder of this document and conditions issued herewith. Any holder of this document is advised that information contained herein reflects the Company's findings at the time of its issuance only and shall be void of effect if any. The Company's sole responsibility is to its Client and this document does not constitute parties to a transaction from acquiring all their rights and obligations under the transaction documents. This document cannot be reproduced except in full, without prior written approval of the Company. Any unauthorized alteration, forgery or falsification of the content or appearance of this document is illegal and will render only the falsified content of the text.
 Unless otherwise stated the results shown in this report refer only to the sample(s) tested and such sample(s) are retained for 180 days only.

F062 Version3

SGS Testing Korea Co., Ltd.

322, The O valley, 595-6, Hoggae-dong, Dongan-gu, Anyang-si, Gyeonggi-do, Korea 431-080
 T +82 (0)31 4808 000 F +82 (0)31 4808 050 <http://www.sgs.com> <http://www.kr.sgs.com> sgs@sgs.com

Member of the SGS Group (Société Générale de Surveillance)



Test Report No. F690501/LF-CTSAYAA09-20354

Issued Date: July 17, 2009

Page 3 of 4

Sample No. : AYAA09-20354.001
 Sample Description : LED
 Item No./Part No. : SLHNNWW629T1(SLHNNWH629T)

Halogen Contents

Test Items	Unit	Test Method	MDL	Results
Fluorine(F)	mg/kg	BS EN 14582:2007 , IC	30	76
Chlorine(Cl)	mg/kg	BS EN 14582:2007 , IC	30	N.D.
Bromine(Br)	mg/kg	BS EN 14582:2007 , IC	30	N.D.
Iodine(I)	mg/kg	BS EN 14582:2007 , IC	50	N.D.

Other(s)

Test Items	Unit	Test Method	MDL	Results
PFOS(Perfluorooctane Sulfonates-Acid/Metal Salt/Amide)	mg/kg	US EPA 3540C/3550C, LC/MS	1	N.D.

NOTE: (1) N.D. = Not detected.(<MDL)
 (2) mg/kg = ppm
 (3) MDL = Method Detection Limit
 (4) - = No regulation
 (5) ** = Qualitative analysis (No Unit)
 (6) * = Boiling-water-extraction:
 Negative = Absence of CrVI coating
 Positive = Presence of CrVI coating; the detected concentration in boiling-water-extraction solution is equal or greater than 0.02 mg/kg with 50 cm² sample surface area.

This document is issued by the Company subject to its General Conditions of Service printed material, available on request or downloadable at www.sgs.com and, for electronic format documents, subject to Terms and Conditions for Electronic Documents at www.sgs.com/sgsweb/guest.nsf. Member is aware of the limitation of liability, indemnification and jurisdiction issues defined therein. Any holder of this document is advised that information contained herein reflects the Company's findings at the time of its issuance only and neither the tests of Client's evaluation, if any. The Company's sole responsibility is to the Client and this document does not constitute a promise or a transaction from marketing all these rights and obligations under the transaction documents. This document cannot be reproduced except in full, without prior written approval of the Company. Any unauthorized alteration, forgery or falsification of the content or appearance of this document is prohibited and offenders may be prosecuted to the fullest extent of the law. Unless otherwise stated the results shown in this test report refer only to the specific test and each sample(s) as referred for test data only.

F052 Version3

SGS Testing Korea Co.,Ltd.

322, The D valley, 565-6, Hoggae-dong, Dongan-gu, Anyang-si, Gyeonggi-do, Korea 431-000
 T +82 (0)31 4928 050 F +82 (0)31 4856 050 <http://www.sgs.com> www.kr.sgs.com sgs@sgs.com

Member of the SGS Group (Société Générale de Surveillance)



Test Report No. F690501/LF-CTSAYAA09-20354

Issued Date: July 17, 2009

Page 4 of 4

Picture of Sample as Received:



*** End ***

- NOTE:
- (1) N.D. = Not detected.(<MDL)
 - (2) mg/kg = ppm
 - (3) MDL = Method Detection Limit
 - (4) - = No regulation
 - (5) ** = Qualitative analysis (No Unit)
 - (6) * = Boiling-water-extraction:
 Negative = Absence of CrVI coating
 Positive = Presence of CrVI coating; the detected concentration in boiling-water-extraction solution is equal or greater than 0.02 mg/kg with 50 cm2 sample surface area.

This document is issued by the Company subject to its General Conditions of Service (please contact), available on request or accessible at www.sgs.com and, for electronic format documents, subject to Terms and Conditions for Electronic Documents at www.sgs.com/secure/electronic.htm. Permission is granted to the holder of this copy, reproduction and publication is strictly prohibited. Any holder of this document is advised that information contained herein reflects the Company's findings at the time of its issuance only and shall be void of Client's evaluation, if any. The Company's sole responsibility is to its Client and this document does not constitute grounds for a transaction from exercising all their rights and obligations under the applicable documents. This document cannot be reproduced except in full, without prior written approval of the Company. Any unauthorized alteration, forgery or falsification of the content or appearance of this document is unlawful and offenders may be prosecuted to the fullest extent of the law. Unless otherwise stated the results shown in this document refer only to the sample(s) tested and such sample(s) are retained for 30 days only.

FOE2 Version3

SGS Testing Korea Co., Ltd.

322, The Ovalley, 555-9, Hogeje-dong, Dongan-gu, Anyang-si, Gyeonggi-do, Korea 431-000
 T +82 (0)31 4958 000 F +82 (0)31 4958 050 <http://www.sgslab.co.kr> www.kr.sgs.com/greenlab

Member of the SGS Group (Société Générale de Surveillance)

Revision History
 (Model : SLHNNWH629T1S0Q2T2)

Date	Revision History	Author	
		Drawn	Approved
2009.07.29	Initial Edition - Preliminary	M.J.Kim	H.K.Kim