

A	C	P	REV	DATE	BY	ECN #	REV	DATE	BY	ECN #	REV	DATE	BY	ECN #
X	-	-	F	6/12/98	SC	3188	G	7/29/99	SC	3595	G1		SC	3755

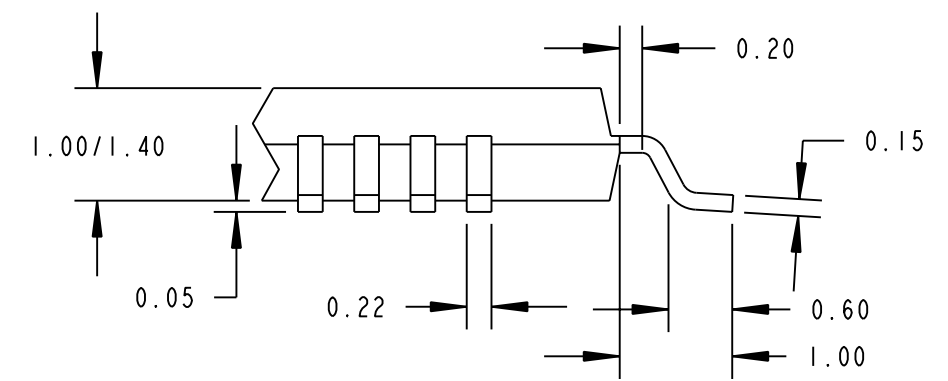

ALL PACKAGE DIMENSIONS ARE FOR REFERENCE ONLY  
PACKAGE SPECIFICATION IS JEDEC MS-026

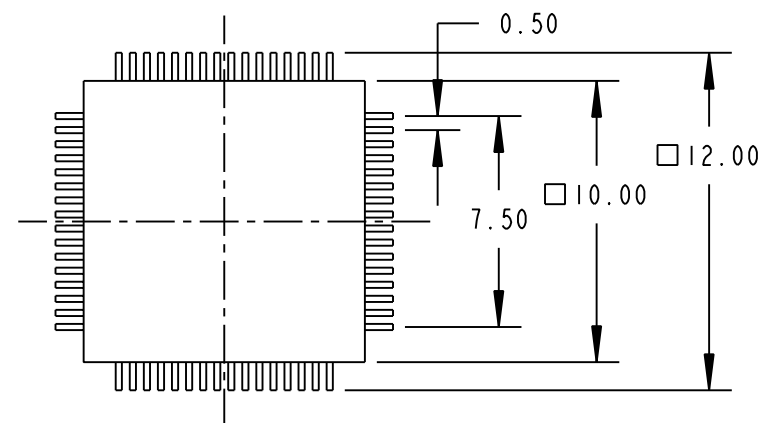
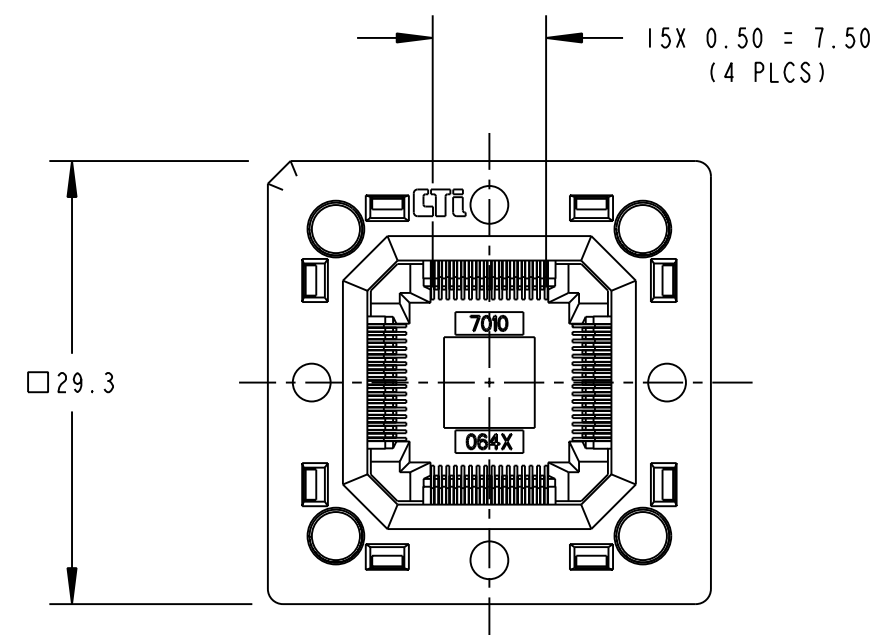
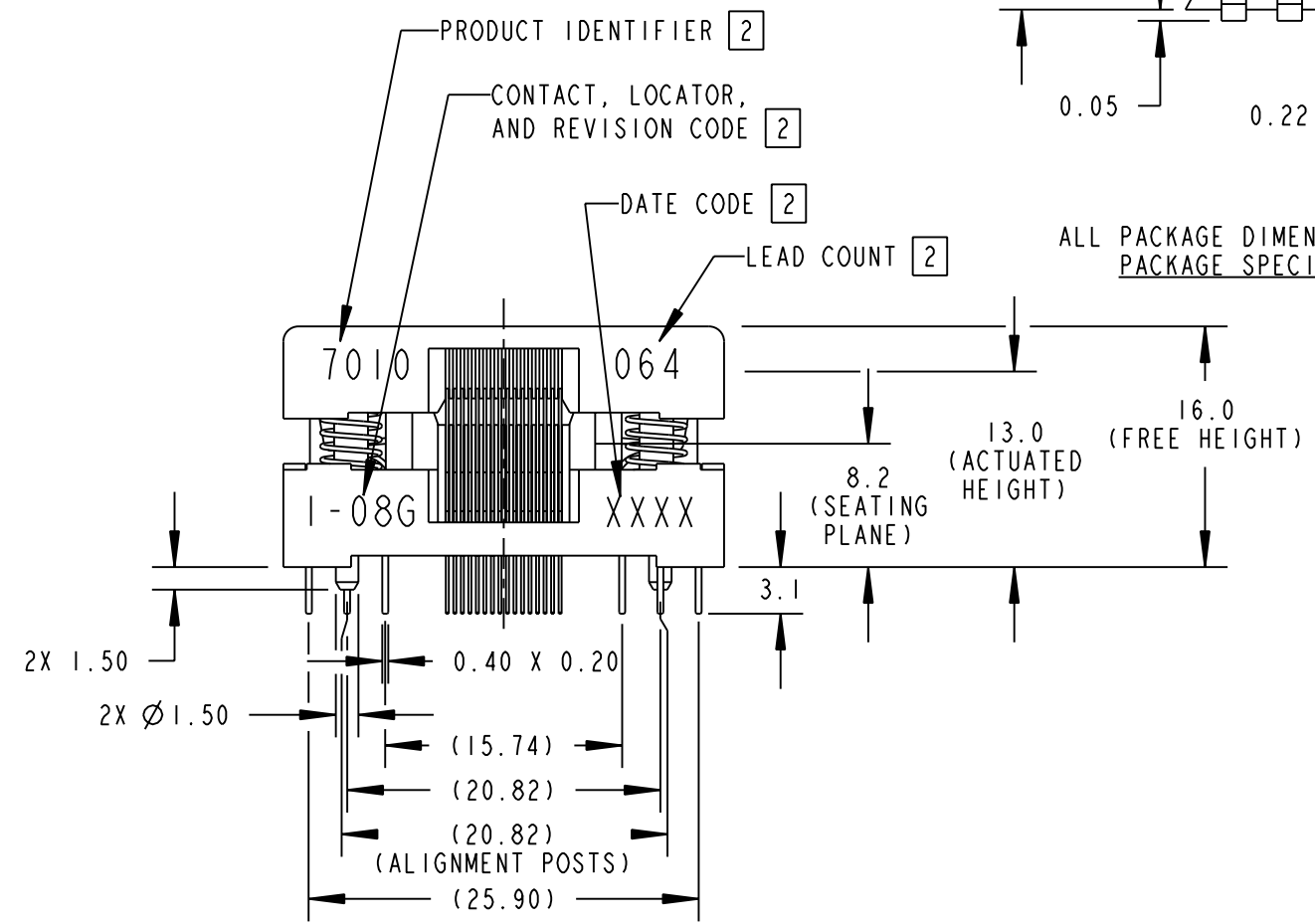
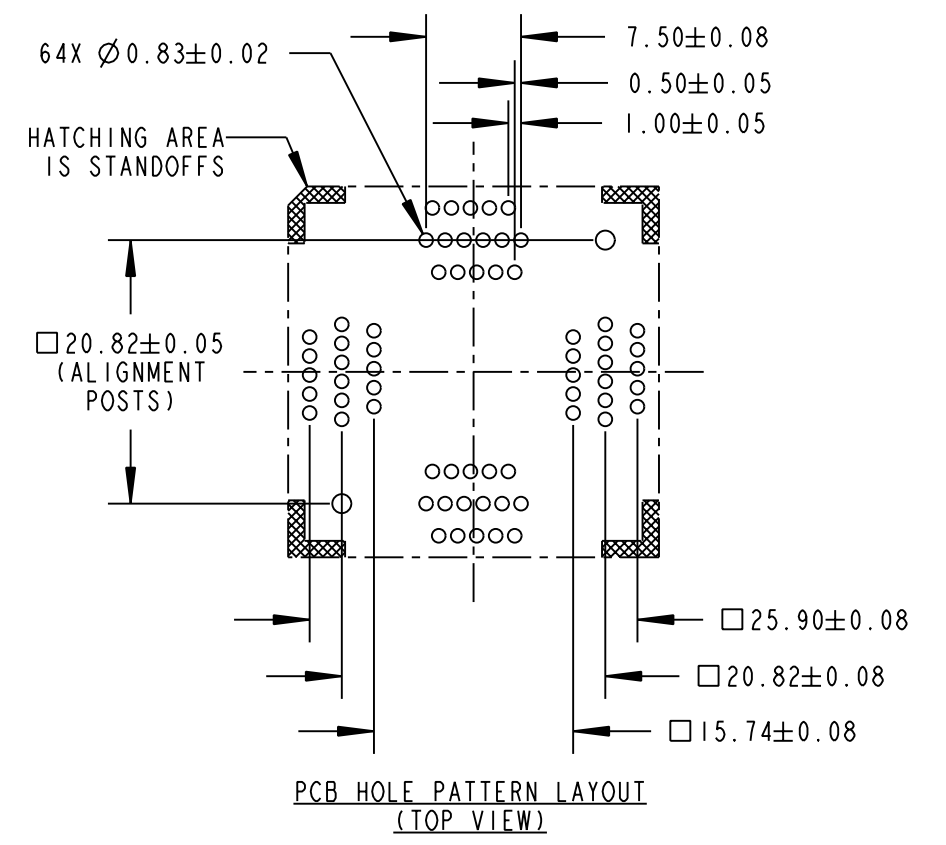

- NOTES:
- MATERIAL AND FINISH:  
SOCKET LID - POLYETHERIMIDE.  
SOCKET BASE - POLYETHERIMIDE.  
CONTACTS - BeCu, SELECTIVE Au-SnPb OVER Ni PLATING.  
SPRINGS - STAINLESS STEEL, PASSIVATED.
  - MARKING: 2.0 HIGH, COLOR - WHITE.
  - REFER TO SK-0283 FOR CONTACT SEATING HEIGHTS.
  - REFER TO SK-0319 FOR NAIL/RIVET PRESS HEIGHTS.

LEGEND		THIS DOCUMENT CONTAINS PROPRIETARY INFORMATION THAT IS THE SOLE PROPERTY OF WELLS-CTI. THIS INFORMATION IS TO BE HELD BY ITS RECIPIENT ON A CONFIDENTIAL BASIS, AND IS NOT TO BE DISCLOSED TO OTHERS OR USED WITHOUT WRITTEN CONSENT OF WELLS-CTI.	MATERIAL/FINISH	DRAWN	<b>WELLS-CTI</b> A subsidiary of PCD Inc. Phoenix Arizona USA	
©	CRITICAL		REFERENCE	CHECKED		
0	NUMBER OF © USED		PROJECT/SERIES	ENGINEER		
SIZE	PROJECTION		ENG. SUPRV.		PART NUMBER	
B			MFG. ENG.		7010-064-1-08	
			MOLDING		SCALE 2.0:1	REV
			TOOLING		CAD NUMBER	G1
		DO NOT SCALE			UNITS: mm [in]	
						SHEET 1