

Precision Shear Web Disk



FEATURES

- Capacities: 0.2, 0.5, 1, 1.5, 2.5, 5, 10, and 25 tons
- Compact size with low profile
- Low deflection for high output
- Electroless nickel plated alloy tool steel construction
- Off center load compensated
- OIML C3 available for whole series

OPTIONAL FEATURES

- PSD-SJTT and PSD-SJTH with different loading holes

DESCRIPTION

A low profile design that makes PSD the most suitable application concerning critical height for safety reasons. The shear web design provides excellent performance even when side forces are inevitable in normal operations. The typical example for side force resistance is the application in motor truck scales.

PSD is constructed of alloy steel and is fully potted with special chemical compounds to IP67 to protect the cell from water and moisture attack.

APPLICATIONS

- Testing machines
- Platform scales
- Hopper and vessel weighing
- Truck scales

OUTLINE DIMENSIONS

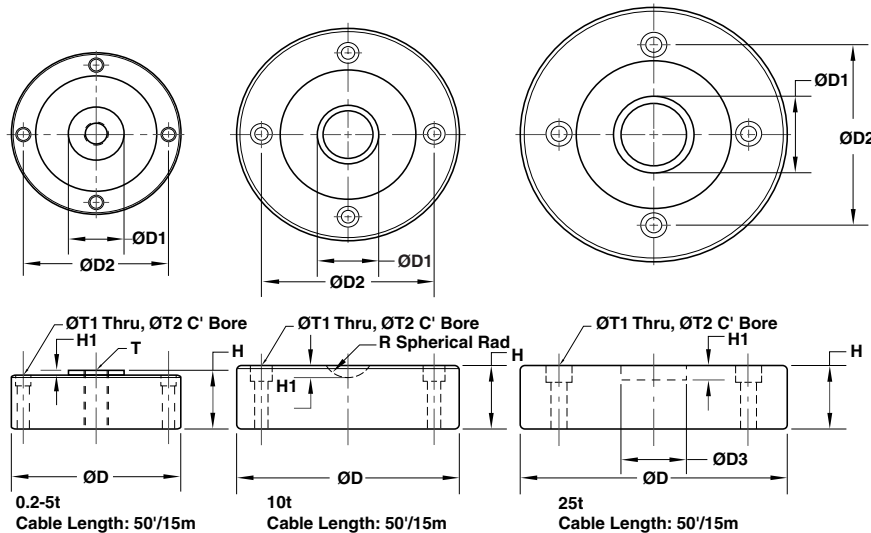

Wiring diagram
 + Excitation Red
 - Excitation Black
 + Signal Green
 - Signal White

CAPACITY		D	D1	D2	D3	H	H1	R	T	T1	T2
200kg	mm	75	----	65.5	----	26	----	----	M12 x 6H	6.5	----
	(inch)	2.95	----	2.58	----	1.02	----	----		0.25	----
500kg/1t	mm	90	2.2	78	----	43	3.05	----	M12 x 1.75	6.6	10.5 x 6.0DP
	(inch)	3.54	0.87	3.07	----	1.69	0.12	----		0.26	0.41 x 0.24DP
1.5/2.5t/5t	mm	104.7	32.0	88.9	----	34.8	3.05	----	M16 x 1.5	7.2	10.5 x 7.2DP
	(inch)	4.12	1.26	3.50	----	1.37	0.12	----		0.28	0.41 x 0.28DP
10t	mm	138.0	38.9	106.4	----	41.1	7.62	22.2	----	8.7	13.5 x 9.7DP
	(inch)	5.43	1.53	4.19	----	1.62	0.30	0.87		0.34	10.5 x 7.2DP
25t	mm	165.0	50.4	116.8	42.0	41.1	8.0	----	----	10.3	15.9 x 10.2DP
	(inch)	6.50	1.98	4.60	1.65	1.62	0.31	----		0.41	0.63 x 0.40DP



SPECIFICATIONS

PARAMETER	VALUE		UNIT
	C3	Non-Approved	
NTEP/OIML Accuracy class	C3	Non-Approved	
Maximum no. of intervals (n)	3000	1000	
$Y = E_{max}/V_{min}$	8000	5000	Maximum available
Standard capacities (E_{max})	200, 500, 1000, 1500, 2500, 5000, 10000, 25000		kg
Rated output-R.O.	3.0**		mV/V
Rated output tolerance	0.25		±% of rated output
Zero balance	1		±% of rated output
Non linearity	0.025		±% of rated output
Hysteresis	0.025		±% of rated output
Non-repeatability	0.020		±% of rated output
Creep error (20 minutes)	0.030		±% of rated output
Zero return (20 minutes)	0.030		±% of rated output
Temperature effect on min. dead load output	0.0017	0.0026	±% of rated output/°C
Temperature effect on sensitivity	0.0010	0.0015	±% of applied load/°C
Compensated temperature range	-10 to +40		°C
Operating temperature range	-20 to +60		°C
Safe overload	150		% of R.C.
Ultimate overload	300		% of R.C.
Excitation, recommended	10		Vdc or Vac rms
Excitation, maximum	15		Vdc or Vac rms
Input impedance	385±5		Ω
Output impedance	350±3		Ω
Insulation resistance	>5000		MΩ
Construction	Nickel plated alloy steel*		
Environmental protection	IP67		

* 200kg is made of aluminum.

** 200kg is 2mV/V.

All specifications listed subject to change without notice.

VISHAY TRANSDUCERS (VT) SALES OFFICES

VT Americas
 City of Industry, CA
 PH: +1-626-858-8899
 FAX: +1-626-332-3418
 vt.us@vishaymg.com

VT Netherlands
 Breda
 PH: +31-76-548-0700
 FAX: +31-76-541-2854
 vt.nl@vishaymg.com

VMG UK
 Basingstoke
 PH: +44-125-646-2131
 FAX: +44-125-647-1441
 vt.uk@vishaymg.com

VMG Israel
 Netanya
 PH: +972-9-863-8888
 FAX: +972-9-863-8800
 vt.il@vishaymg.com

VMG Germany
 Heilbronn
 PH: +49-7131-3901-260
 FAX: +49-7131-3901-2666
 vt.de@vishaymg.com

VT China
 Tianjin
 PH: +86-22-2835-3503
 FAX: +86-22-2835-7261
 vt.prc@vishaymg.com

VMG France
 Chartres
 PH: +33-2-37-33-31-20
 FAX: +33-2-37-33-31-29
 vt.fr@vishaymg.com

VT Taiwan*
 Taipei
 PH: +886-2-2696-0168
 FAX: +886-2-2696-4965
 vt.roc@vishaymg.com
 *Asia except China



Notice

Specifications of the products displayed herein are subject to change without notice. Vishay Intertechnology, Inc., or anyone on its behalf, assumes no responsibility or liability for any errors or inaccuracies.

Information contained herein is intended to provide a product description only. No license, express or implied, by estoppel or otherwise, to any intellectual property rights is granted by this document. Except as provided in Vishay's terms and conditions of sale for such products, Vishay assumes no liability whatsoever, and disclaims any express or implied warranty, relating to sale and/or use of Vishay products including liability or warranties relating to fitness for a particular purpose, merchantability, or infringement of any patent, copyright, or other intellectual property right.

The products shown herein are not designed for use in medical, life-saving, or life-sustaining applications. Customers using or selling these products for use in such applications do so at their own risk and agree to fully indemnify Vishay for any damages resulting from such improper use or sale.