

Heavy Duty Compression Load Cell



FEATURES

- Capacities 50 - 150 ton
- Ideal for multi-cell applications
- Compact, economical, column design
- Hermetically sealed to IP68
- 6 Wire (sense) circuit
- Stainless steel housing as standard

DESCRIPTION

Model 122 is a heavy duty general purpose compression load cell particularly well suited for hopper and tank weighing and many other large scale industrial applications, including weighbridges for truck weighing.

The simple, compact column design and rugged hermetically sealed construction of the model 122 load cell assures its long term life in all types of field installations.

The model 122 load cell is often used in multi-cell installations, therefore its standard output tolerance is within 0.1%.

The two additional sense wires feed back the voltage reaching the load cell. Complete compensation of changes in lead resistance due to temperature change and/or cable extension, is achieved by feeding this voltage into the appropriate electronics.

APPLICATIONS

- Hopper and tank weighing
- Truck weighbridges

OUTLINE DIMENSIONS in millimeters

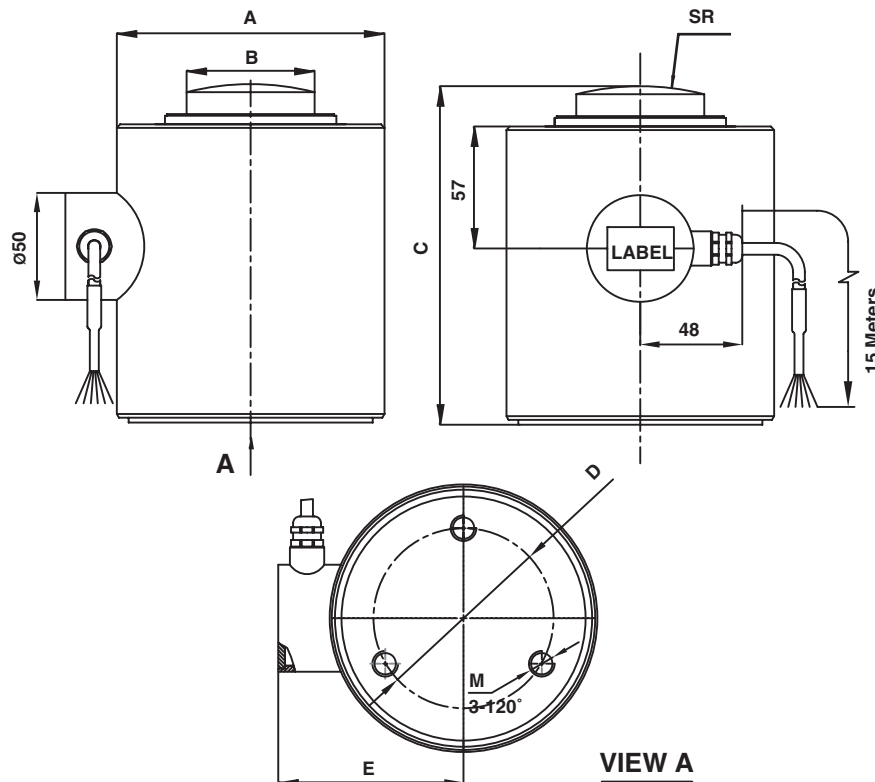

CAPACITY	A	B	C	D	E	M	SR
50T	Ø88	Ø45	122	Ø50	69	M10	SR35
100T, 150T	Ø125	Ø59.8	158	Ø84	86.5	M12	SR120

SPECIFICATIONS

PARAMETER	VALUE			UNIT
	50	100	150	
Rated capacity-R.C. (E_{max})	50	100	150	ton
NTEP/OIML Accuracy class	Non-Approved*			
Maximum no. of intervals (n)	2000			
$Y = E_{max}/V_{min}$	2000			
Rated output-R.O.	1.5		2	mV/V
Rated output tolerance	0.0015			±mV/V
Zero balance	0.015		0.02	±mV/V
Zero Return, 30 min.	0.030			±% of applied load
Total Error (per OIML R60)	0.030			±% of rated output
Temperature effect on zero	0.03			±% of rated output/°C
Temperature effect on output, unbalanced	0.0080**			±% of load/°C
Temperature range, compensated	5 to +45			°C
Temperature range, safe	-20 to +60			°C
Maximum safe central overload	150			% of R.C.
Ultimate central overload	200			% of R.C.
Excitation, recommended	10			Vdc or Vac rms
Excitation, maximum	15			Vdc or Vac rms
Input impedance	670±15	1270±20	1350±30	Ohm
Output impedance	600±5	1205±5	1205±5	Ohm
Insulation resistance	>2000			Mega-Ohm
Cable length	15			m
Cable type	6 wire, braided, PVC, single floating screen			Standard
Construction	Stainless steel housing, plated alloy steel sensor			
Environmental protection	IP68			

* Typical 80% utilization

** Balanced span compensation is available upon request.

WIRING SCHEMATIC DIAGRAM
(unbalanced bridge configuration)

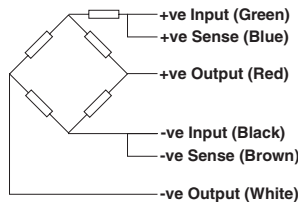

VISHAY TRANSDUCERS (VT) SALES OFFICES

VT Americas
City of Industry, CA
PH: +1-626-858-8899
FAX: +1-626-332-3418
vt.us@vishaymg.com

VT Netherlands
Breda
PH: +31-76-548-0700
FAX: +31-76-541-2854
vt.nl@vishaymg.com

VMG UK
Basingstoke
PH: +44-125-646-2131
FAX: +44-125-647-1441
vt.uk@vishaymg.com

VMG Israel
Netanya
PH: +972-9-863-8888
FAX: +972-9-863-8800
vt.il@vishaymg.com

VMG Germany
Heilbronn
PH: +49-7131-3901-260
FAX: +49-7131-3901-2666
vt.de@vishaymg.com

VT China
Tianjin
PH: +86-22-2835-3503
FAX: +86-22-2835-7261
vt.prc@vishaymg.com

VMG France
Chartres
PH: +33-2-37-33-31-20
FAX: +33-2-37-33-31-29
vt.fr@vishaymg.com

VT Taiwan*
Taipei
PH: +886-2-2696-0168
FAX: +886-2-2696-4965
vt.roc@vishaymg.com
*Asia except China