

3-terminal Regulator & LDO Regulator Series



Standard Fixed Output LDO Regulator

BA□□DD0, BA□□DD0W, BA□□CC0 and BA□□CC0W Series

●General Description

BA□□DD0/CC0 are low-saturation regulators, available for output s up to 2A/1A. ROHM has a wide output voltage range and package lineup with and without shutdown switches. This IC has a built-in over-current protection circuit that prevents the destruction of the IC due to output short circuits, a thermal shut-down circuit that protects the IC from damage due to overloading and an over-voltage protection circuit that protects the IC from surges generated in the power supply line of the IC.

●Features

- 1) Maximum output current : 2A (BA□□DD0), 1A(BA□□CC0)
- 2) ±1% highly accurate output voltage (BA□□DD0)
- 3) Low saturation with PNP output
- 4) Built-in over-current protection circuit that prevents the destruction of the IC due to output short circuits
- 5) Built-in thermal shutdown circuit for protecting the IC from damage due to overloading
- 6) Built-in over-voltage protection circuit that prevents the destruction of the IC due to power supply surges
- 7) TO220FP and HRP5 packaging (BA□□DD0) TO220FP and TO252 packaging(BA□□CC0)

●Applications

Used in DSP power supplies for DVD and CD players, FPDs, televisions, personal computers or any other consumer device

●Line up

■1A BA□□CC0 Series

Part Number	3.0	3.3	5.0	6.0	7.0	8.0	9.0	10	12	15	Package
BA□□CC0WT	○	○	○	—	○	○	○	○	○	—	TO220FP-5
BA□□CC0WT-V5	—	○	○	—	—	○	○	—	○	—	TO220FP-5 (V5)
BA□□CC0WFP	—	○	○	○	○	○	○	—	○	—	TO252-5
BA□□CC0T	○	○	○	—	○	○	○	○	○	○	TO220FP-3
BA□□CC0FP	○	○	○	○	○	○	○	○	○	○	TO252-3

■2A BA□□DD0 Series

Part Number	1.5	1.8	2.5	3.0	3.3	5.0	9.0	12	16	Package
BA□□DD0WT	○	○	○	○	○	○	○	○	○	TO220FP-5
BA□□DD0WHP	○	○	○	○	○	○	○	○	○	HRP5
BA□□DD0T	○	○	○	○	○	○	○	○	○	TO220FP-3

Part Number : BA□□CC0□□
a b c

Part Number : BA□□DD0□□
a b c

Symbol	Details			
a	Output Voltage Designation			
	□□	Output Voltage(V)	□□	Output Voltage(V)
	03	3.0V(Typ.)	08	8.0V(Typ.)
	033	3.3V(Typ.)	09	9.0V(Typ.)
	05	5.0V(Typ.)	J0	10.0V(Typ.)
	06	6.0V(Typ.)	J2	12.0V(Typ.)
	07	7.0V(Typ.)	J5	15.0V(Typ.)
b	Switch:"With W":Shutdown switch included "Without W":Shutdown switch not included			
c	Package T:TO220FP-5 (V5), TO220FP-3 FP:TO252-5, TO252-3			

Symbol	Details			
a	Output Voltage Designation			
	□□	Output Voltage(V)	□□	Output Voltage(V)
	15	1.5V(Typ.)	50	5.0V(Typ.)
	18	1.8V(Typ.)	90	9.0V(Typ.)
	25	2.5V(Typ.)	J2	12.0V(Typ.)
	30	3.0V(Typ.)	J6	16.0V(Typ.)
	33	3.3V(Typ.)		
b	Switch:"With W":Shutdown switch included "Without W":Shutdown switch not included			
c	Package T:TO220FP-5, TO220FP-3 HFP:HRP5			

● Absolute Maximum Ratings(Ta=25°C)

Parameter	Symbol	Limits	Unit
Input Power Supply Voltage *1	Vcc	-0.3~+35	V
Power Dissipation *2	Pd	2300 (HRP5)	mW
		1300 (TO252-5)	
		1200 (TO252-3)	
		2000 (TO220FP-3,5)	
Operating Temperature Range	Topr	-40~+125	°C
Ambient Storage Temperature	Tstg	-55~+150	°C
Junction Temperature	Tjmax	+150	°C
Output Control Terminal Voltage *3	VCTL	-0.3~+Vcc	V
Voltage Applied to the Tip *4	Vcc peak	+50	V

*1 Must not exceed Pd

*2 HRP5 : In cases in which Ta≥25°C when a 70mm×70mm×1.6mm glass epoxy board is used, the power is reduced by 18.4 mW/°C.
 TO252FP-3 : In cases in which Ta≥25°C when a 70mm×70mm×1.6mm glass epoxy board is used, the power is reduced by 9.6 mW/°C.
 TO252FP-5 : In cases in which Ta≥25°C when a 70mm×70mm×1.6mm glass epoxy board is used, the power is reduced by 10.4 mW/°C.
 TO220FP-5 : No heat sink. When Ta≥25°C, the power is reduced by 16 mW/°C.

*3 Only for models with shutdown switches.

*4 Applied voltage : 200msec or less (tr≥1msec)

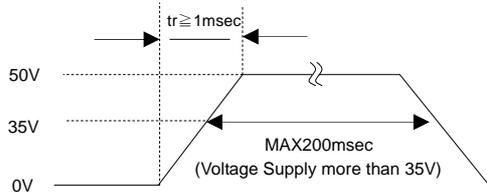

● Recommended Operating Range (Ta=25°C)

Parameter	Symbol	Min.	Max.	Unit	
Input Power Supply Voltage	BA□□CC0	Vcc	4.0	25.0	V
	BA□□DD0		3.0	25.0	
Output Current	BA□□CC0	Io	—	1	A
	BA□□DD0		—	2	
Output Control Terminal Voltage	VCTL	0	Vcc	V	

● Electrical Characteristics(ABRIDGED)

BA□□CC0 Series (unless specified otherwise, Ta=25°C, VCTL=5.0V(only with switch), Io=500mA, and Vcc=VccD*5)

Parameter	Symbol	Min.	Typ.	Max.	Unit	Conditions
Output Voltage	Vo	Vo×0.98	Vo	Vo×1.02	V	Refer to the lineup for Vo
Circuit Current at Shutdown	I _{sd}	—	0	10	μA	VCTL=0V
Minimum I/O Difference	Vd	—	0.3	0.5	V	Vcc= 0.95×Vo
Output Current Capacity	Io	1.0	—	—	A	
Input Stability	Reg.I	—	20	100	mV	Vcc= (Vo+1)V → 25V
Load Stability	Reg.L	—	50	100	mV	Io=5mA→1A
Output Voltage Temperature Coefficient*6	TcVo	—	±0.02	—	%/°C	Io=5mA, Tj=0~125°C

BA00DD0□□ series (unless specified otherwise, Ta=25°C, VCTL=3V(only with switch), Io=500mA, and Vcc=VccD*7)

Parameter	Symbol	Min.	Typ.	Max.	Unit	Conditions
Output Voltage	Vo	Vo×0.99	Vo	Vo×1.01	V	Io=200mA
Circuit Current at Shutdown	I _{sd}	—	0	10	μA	VCTL=0V
Minimum I/O Difference	Vd	—	0.45	0.7	V	Vcc= 0.95×Vo, Io=2A
Output Current Capacity	Io	2.0	—	—	A	
Input Stability	Reg.I	—	15	50	mV	Vcc= VccD*7 →25 V, Io=200mA
Load Stability	Reg.L	—	50	200	mV	Io=5mA→2A
Output Voltage Temperature Coefficient*6	TcVo	—	±0.02	—	%/°C	Io=5mA, Tj=0~125°C

*5 Vo=3.0V : Vcc= 8.0V, Vo=3.3V : Vcc=8.3V, Vo=5.0V : Vcc=10.0V, Vo=6.0V : Vcc=11.0V, Vo=7.0V : Vcc=12.0V,
 Vo=8.0V : Vcc= 13.0V, Vo=9.0V : Vcc=14.0V, Vo=10.0V : Vcc=15.0V, Vo=12.0V : Vcc=17.0V, Vo=15.0V : Vcc=20.0V

*6 Design guarantee(100% shipping inspection not performed)

*7 Vo=1.5V, 1.8V, 2.5V, 3.0V : Vcc=4.0V, Vo=3.3V, 5.0V : Vcc=7.0V, Vo=9.0V : Vcc=12.0V
 Vo=12V : Vcc=14V, Vo=16V : Vcc=18V

● Reference Data

BA□□CC0□□(BA33CC0WT)

(Unless specified otherwise, $V_{CC}=8.3V$, $V_o=3.3V$, $V_{CTL}=5.0V$, and $I_o=0mA$)

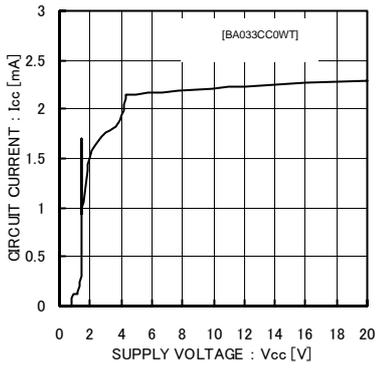

Fig.1 Circuit current

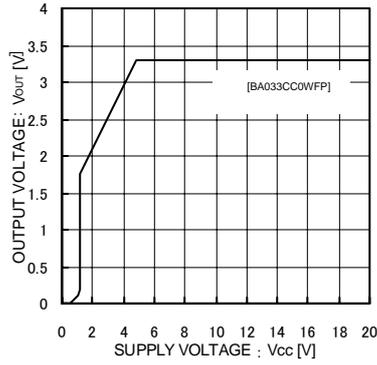

Fig.2 Input Stability

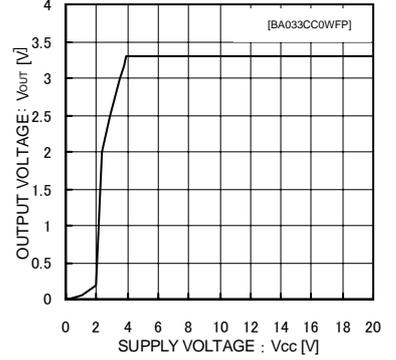

Fig.3 Input Stability
($I_o=500mA$)

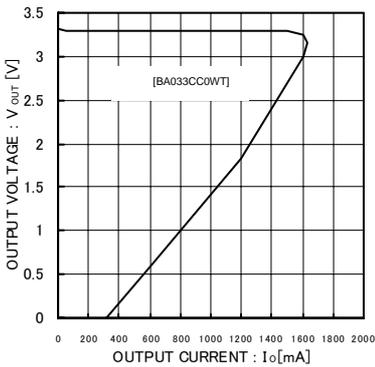

Fig.4 Load Stability

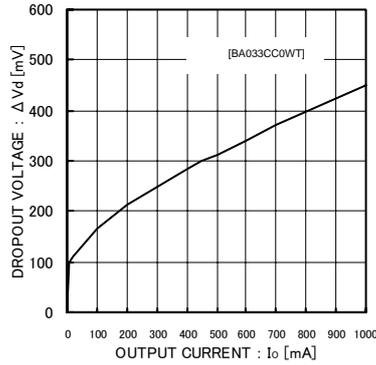

Fig.5 Input/Output Voltage Difference
 $I_{OUT} (0V=1A)$

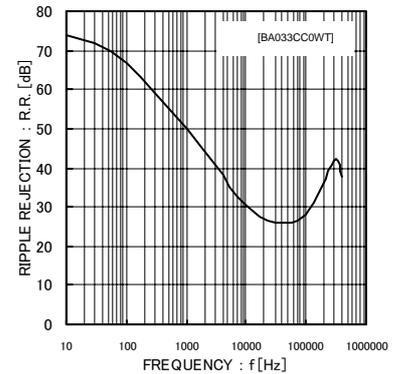

Fig.6 Ripple Rejection Characteristics
($I_o=100mA$)

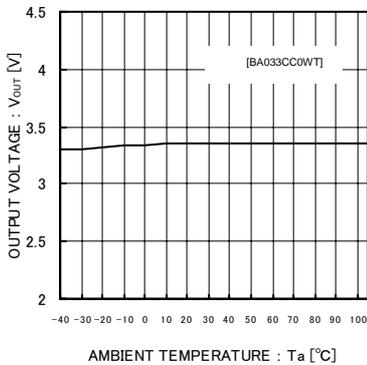

Fig.7 Output Voltage
Temperature Characteristics

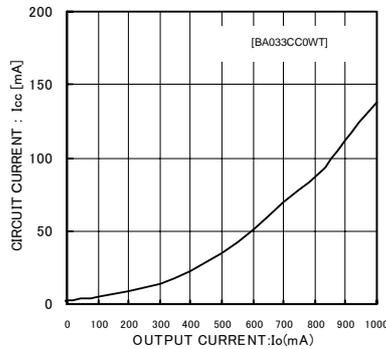

Fig.8 Circuit Current by load Level
($I_{OUT}=0mA \rightarrow 1A$)

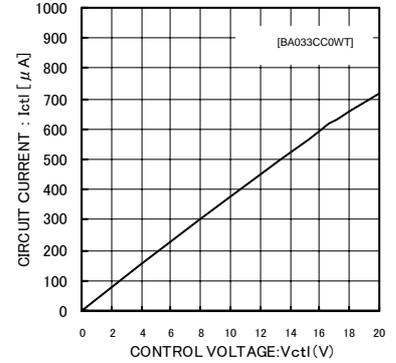

Fig.9 CTL Voltage vs. CTL Current

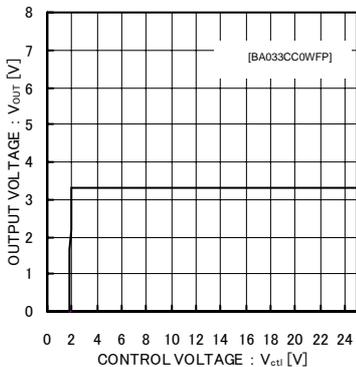

Fig.10 CTL Voltage vs. Output Voltage

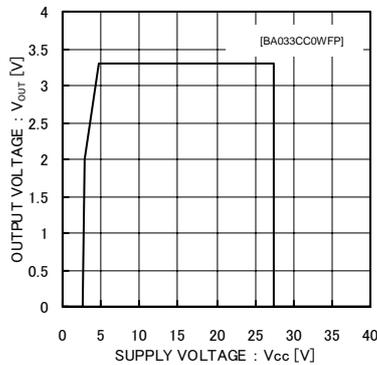

Fig.11 Overvoltage Operating
Characteristics($I_o=200mA$)

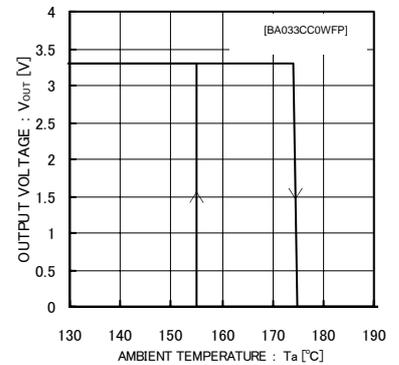

Fig.12 Thermal Shutdown
Circuit Characteristics

● Reference Data

BA□□DD0□□(BA50DD0WT)

(Unless specified otherwise, $V_{cc}=7.0V$, $V_o=5.0V$, $V_{CTL}=3.0V$, and $I_o=0mA$)

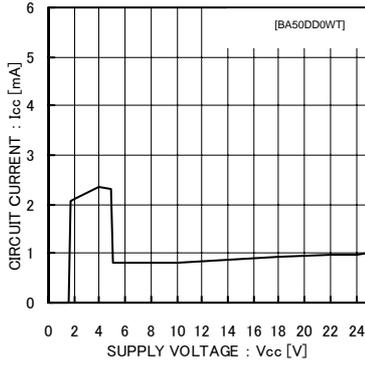

Fig.13 Circuit Current

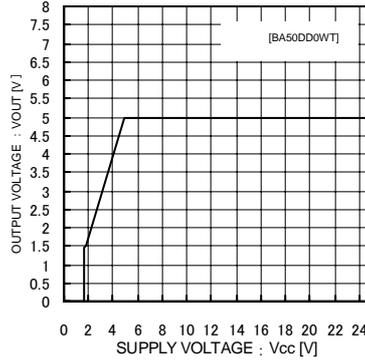

Fig.14 Input Stability

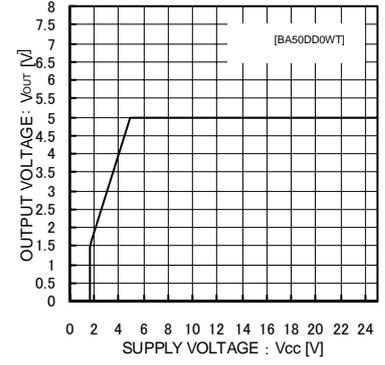

Fig.15 Input Stability

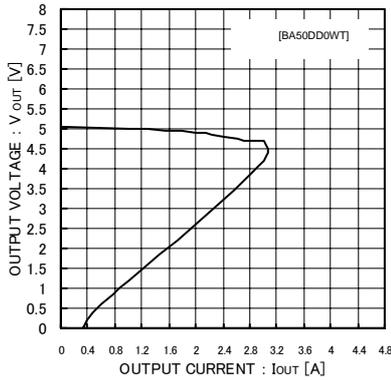

Fig.16 Load Stability

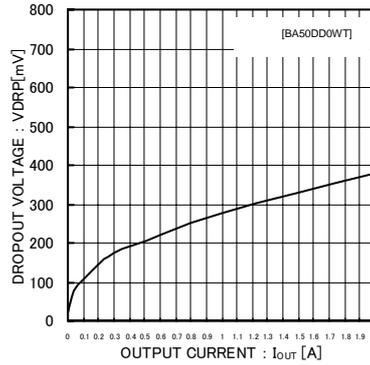

Fig.17 Input/Output Voltage Difference ($V_{cc}=4.75V$)

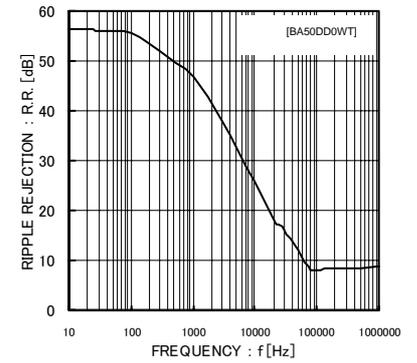

Fig.18 Ripple Rejection Characteristics ($I_{out}=100mA$)

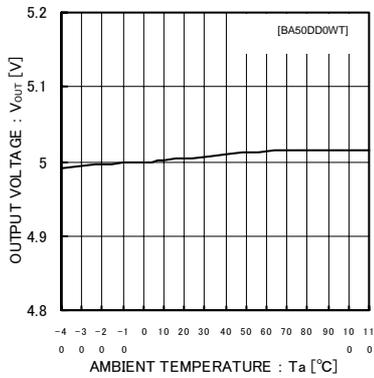

Fig.19 Output Voltage Temperature Characteristics

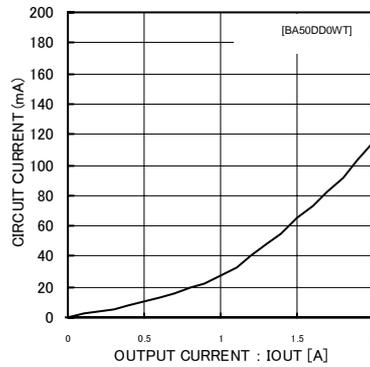

Fig.20 Circuit Current by Load Level ($I_{out}=0mA \rightarrow 2A$)

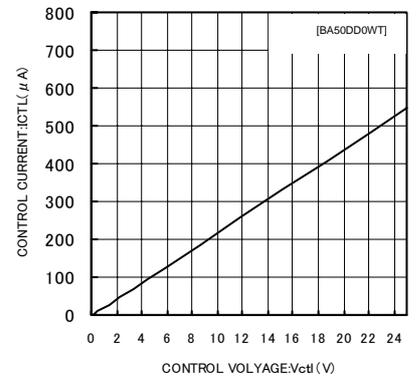

Fig.21 CTL Voltage vs. CTL Current

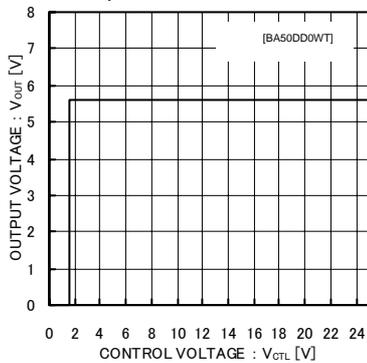

Fig.22 CTL Voltage vs. Output Voltage

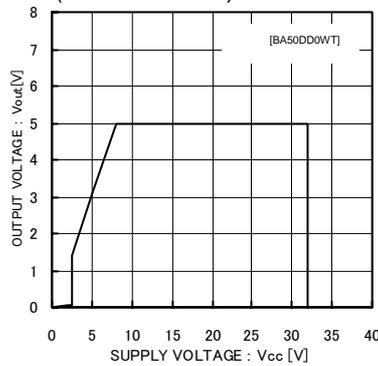

Fig.23 Overvoltage Operating ($I_o=200mA$)

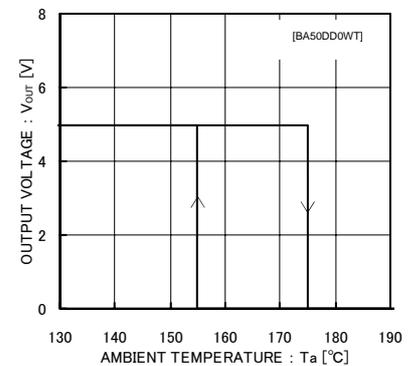

Fig.24 Thermal Shutdown

●Block Diagrams

BA□□CC0WFP/ BA□□DD0WHFP/ BA□□CC0WT(V5)/ BA□□DD0WT

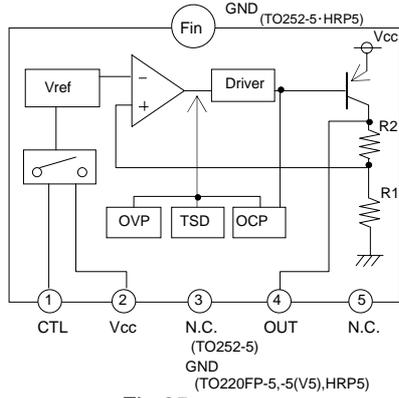
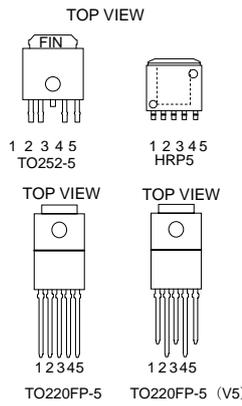

Fig.25



PIN No.	Pin Name	Function
1	CTL	Output voltage ON/OFF control
2	Vcc	Power supply voltage input
3	N.C./GND	Unconnected terminal/GND *1
4	OUT	Voltage output
5	N.C	Unconnected terminal
Fin	GND	GND *2

*1 TO252-5 is N.C.,and TO220FP-5,-5(V5),and HRP5 are GND
*2 Only for TO252-5 and HRP5

BA□□CC0T/ BA□□CC0FP/ BA□□DD0T

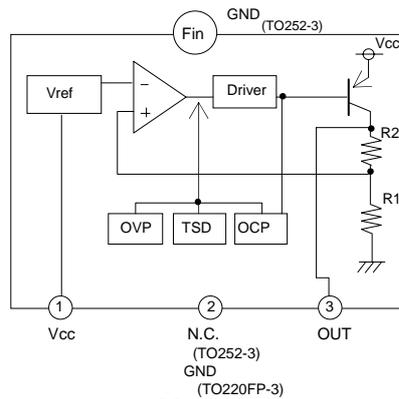
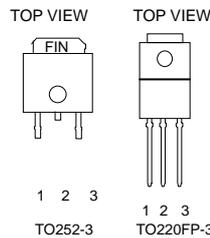

Fig.26



PIN No.	Pin Name	Function
1	Vcc	Power supply voltage input
2	N.C/GND	Unconnected terminal/GND*1
3	OUT	Voltage output
Fin	GND	GND *2

*1 TO252-3 is N.C.,and TO-220FP-3,is GND
*2 Only for TO252-3 and HRP5

●Input / Output Equivalent Circuit Diagrams

< BA□□DD0 Series >

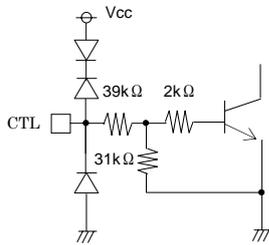

Fig.27

< BA□□CC0 Series >

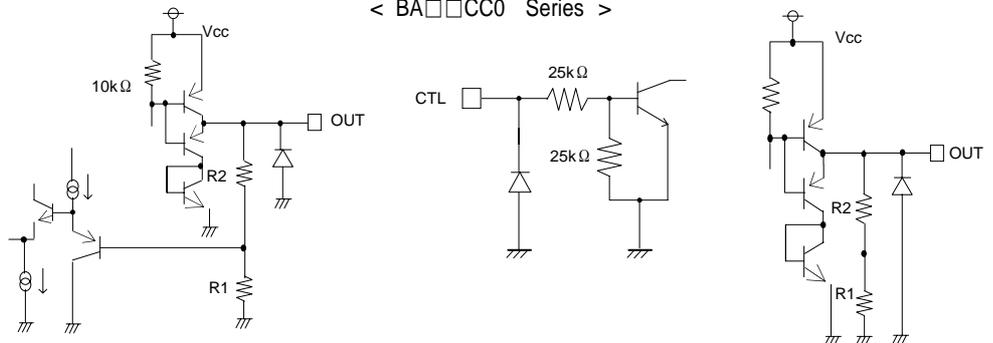

Fig.28

●Thermal Design

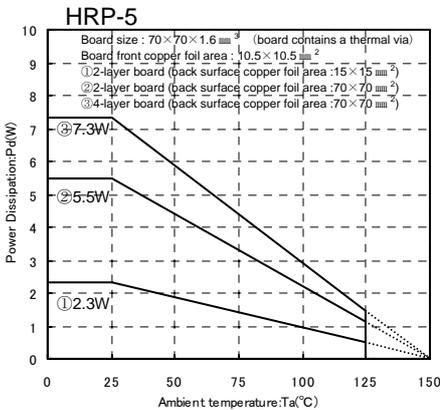

Fig.29

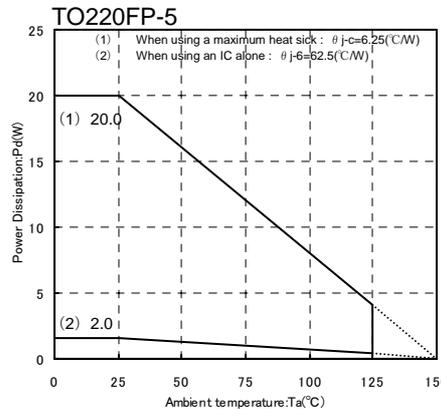

Fig.30

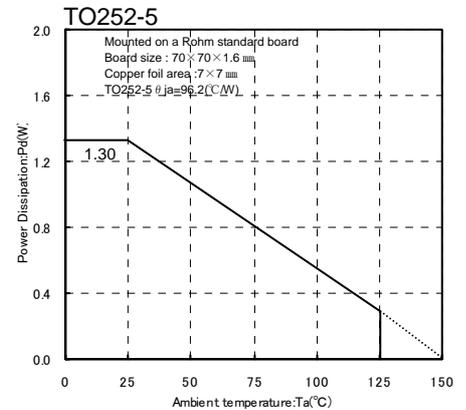

Fig.31

When using at temperatures over $T_a=25^{\circ}\text{C}$, please refer to the heat reducing characteristics shown in Fig.29 through 31. The IC characteristics are closely related to the temperature at which the IC is used and if the temperature exceeds the maximum junction temperature $T_{j\text{MAX}}$, the elements may be damaged or destroyed. From the standpoints of instantaneous destruction and long-term operating reliability, it is necessary give sufficient consideration to IC heat. In order to protect the IC from thermal damage, it is necessary to operate it at temperatures lower than the maximum junction temperature $T_{j\text{MAX}}$ of the IC.

Fig.30 shows the acceptable loss and heat reducing characteristics of the TO220FP package. The portion shown by the diagonal line is the acceptable loss range that can be used with the IC alone. Even when the ambient temperature T_a is a normal temperature (25°C), the chip (junction) temperature T_j may be quite high so please operate the IC at temperatures less than the acceptable loss P_d .

The method of calculating the power consumption $P_c(W)$ is as follows.

$$P_c = (V_{cc} - V_o) \times I_o + V_{cc} \times I_{cca}$$

Acceptable loss $P_d \leq P_c$

V_{cc} : Input voltage
 V_o : Output voltage
 I_o : Load current
 I_{cca} : Circuit current

Solving this for load current I_o in order to operate within the acceptable loss:

$$I_o \leq \frac{P_d - V_{cc} \times I_{cca}}{V_{cc} - V_o}$$

(Please refer to Figs.8 and 20 for I_{cca} .)

It is then possible to find the maximum load current I_{oMAX} with respect to the applied voltage V_{cc} at the time of thermal design.

• Calculation Example

Example 1) When $T_a=85^\circ C$, $V_{cc}=8.3V$, $V_o=3.3V$, BA33DD0WT

$$I_o \leq \frac{1.04 - 8.3 \times I_{cca}}{5}$$

$I_o \leq 200mA$ ($I_{cca} : 2mA$)

With the IC alone : $\theta_{ja}=62.5^\circ C/W \rightarrow -16mW/^\circ C$
 $25^\circ C=2000mW \rightarrow 85^\circ C=1040mW$

Please refer to the above information and keep thermal designs within the scope of acceptable loss for all operating temperature ranges.

The power consumption P_c of the IC when there is a short circuit (short between V_o and GND) is :

$$P_c = V_{cc} \times (I_{cca} + I_{short})$$

* I_{short} : Short circuit current

● Peripheral Circuit Considerations

• Vcc Terminal

Please attach a capacitor (greater than $0.33 \mu F$) between the V_{cc} and GND.

The capacitance values will differ depending on the application, so please take this into account when configuring the terminal.

• GND Terminal

Please be sure to keep the set ground and IC ground at the same potential level so that a potential difference does not arise between them.

If a potential difference arises between the set ground and the IC ground, the preset voltage will not be outputted, causing the system to become unstable. Therefore, please reduce the impedance by making the ground patterns as wide as possible and by reducing the distance between the set ground and the IC ground as much as possible.

• CTL Terminal

The CTL terminal is turned ON at 2.0V and higher and OFF at 0.8V and lower within the operating power supply voltage range.

The power supply and the CTL terminal may be started up and shut down in any order without problems.

● Vo Terminal

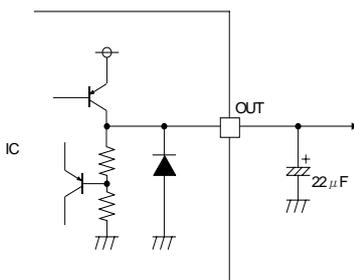

Fig.32 Output Equivalent Circuit

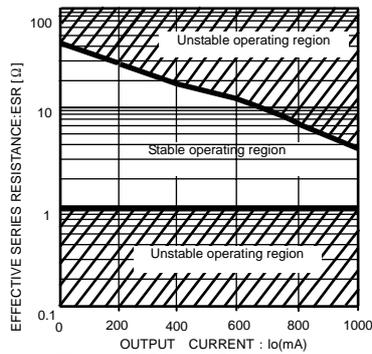

Fig.33 ESR-Io Characteristics (BA□□CC0,22 μF)

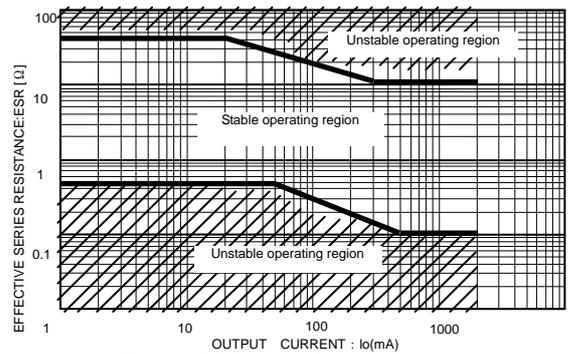

Fig.34 ESR vs Io Characteristics (BA□□DD0,22 μF)

Please attach an anti-oscillation capacitor between V_{cc} and GND. The capacitance of the capacitor may significantly change due to factors such as temperature changes, making it impossible to completely stop oscillations. Please use a tantalum capacitor or aluminum electrolysis capacitor with favorable characteristics and small internal series resistance (ESR) even at low temperatures. The output fluctuates regardless of whether the ESR is large or small. Please use the IC within the stable operating region while referring to the ESR characteristics reference data shown in Figs.32 through 34. In applications where there are sudden load fluctuations, the use of a capacitor with large capacitance is recommended.

Below figure, it is ESR-to- I_o stability Area characteristics, measured by $22 \mu F$ -ceramic-capacitor and resistor connected in series.

This characteristics is not equal value perfectly to $22 \mu F$ -aluminum electrolytic capacitor in order to measurement method.

Note, however, that the stable range suggested in the figure depends on the IC and the resistance load involved, and can vary with the board's wiring impedance, input impedance, and/or load impedance. Therefore, be certain to ascertain the final status of these items for actual use.

Keep capacitor capacitance within a range of $22 \mu F \sim 1000 \mu F$. It is also recommended that a $0.33 \mu F$ bypass capacitor be connected as close to the input pin-GND as location possible. However, in situations such as rapid fluctuation of the input voltage or the load, please check the operation in real application to determine proper capacitance.

● Other Points of Caution

1) Protection Circuits

Over-current Protection Circuit

A built-in over-current protection circuit corresponding to the current capacity prevents the destruction of the IC when there are load shorts. This protection circuit is a "7"-shaped current control circuit that is designed such that the current is restricted and does not latch even when a large current momentarily flows through the system with a high-capacitance capacitor. However, while this protection circuit is effective for the prevention of destruction due to unexpected accidents, it is not suitable for continuous operation or transient use. Please be aware when creating thermal designs that the overcurrent protection circuit has negative current capacity characteristics with regard to temperature (Refer to Figs.4 and 16).

Thermal Shutdown Circuit (Thermal Protection)

This system has a built-in temperature protection circuit for the purpose of protecting the IC from thermal damage. As shown above, this must be used within the range of acceptable loss, but if the acceptable loss happens to be continuously exceeded, the chip temperature T_j increases, causing the temperature protection circuit to operate.

When the thermal shutdown circuit operates, the operation of the circuit is suspended. The circuit resumes operation immediately after the chip temperature T_j decreases, so the output repeats the ON and OFF states (Please refer to Figs.12 and 24 for the temperatures at which the temperature protection circuit operates).

There are cases in which the IC is destroyed due to thermal runaway when it is left in the overloaded state. Be sure to avoid leaving the IC in the overloaded state.

Reverse Current

In order to prevent the destruction of the IC when a reverse current flows through the IC, it is recommended that a diode be placed between the Vcc and Vo and a pathway be created so that the current can escape (Refer to Fig.35).

2) This IC is bipolar IC that has a P-board (substrate) and P+ isolation layer between each device, as shown in Fig.36. A P-N junction is formed between this P-layer and the N-layer of each device, and the P-N junction operates as a parasitic diode when the electric potential relationship is $GND > \text{Terminal A}$, $GND > \text{Terminal B}$, while it operates as a parasitic transistor when the electric potential relationship is $\text{Terminal B} > GND > \text{Terminal A}$. Parasitic devices are structurally inevitable in the IC. The operation of parasitic devices induces mutual interference between circuits, causing malfunctions and eventually the destruction of the IC. It is necessary to be careful not to use the IC in ways that would cause parasitic elements to operate. For example, applying a voltage that is lower than the GND (P-board) to the input terminal.

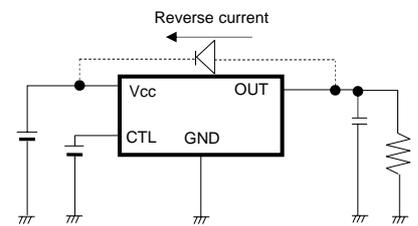

Fig. 36: Bypass diode

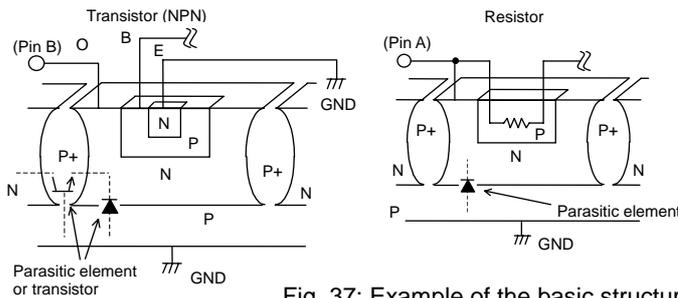
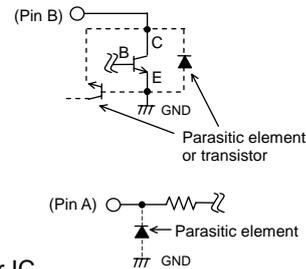
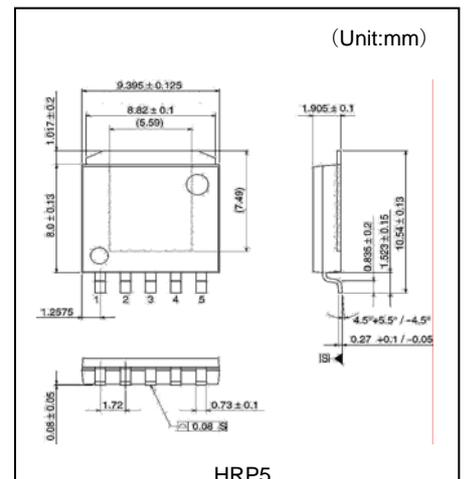
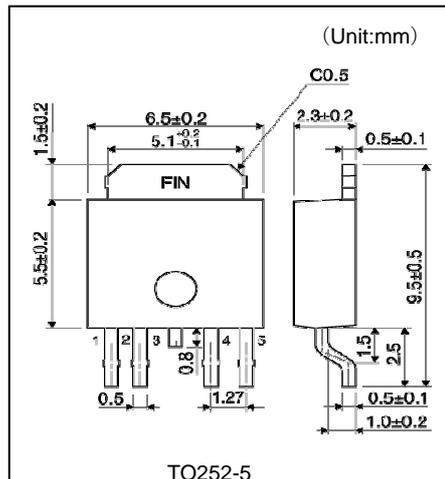
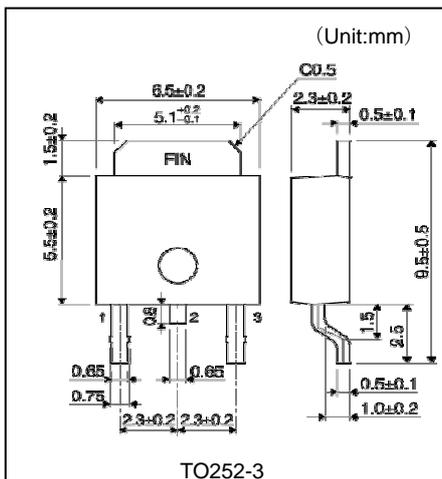
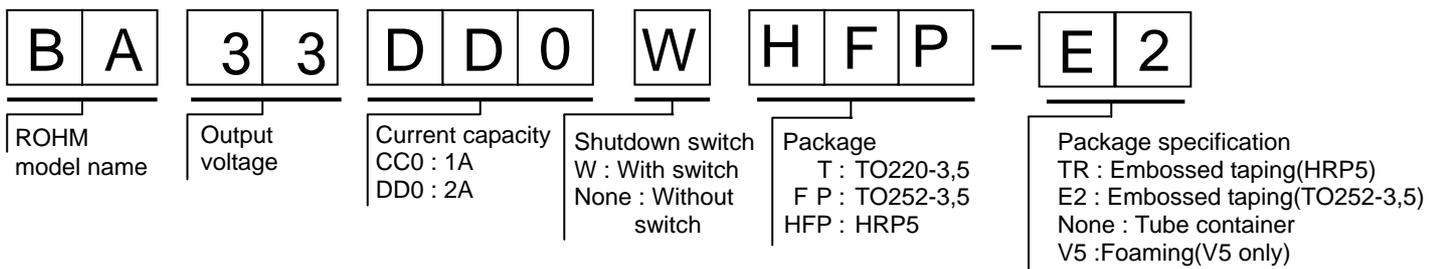

Fig. 37: Example of the basic structure of a bipolar IC



● Part Number Selection



<Package Specification>HRP5

Package Form	Embossed taping
Package Quantity	2000pcs
Package Orientation	TR (When the reek is held with the left hand and the tape is drawn out with the right hand, the No.1 pin of the product faces the upper right direction.)

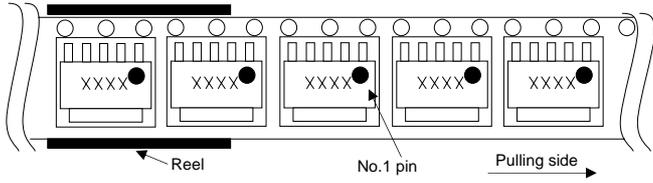

< Package Specification > TO252-3,5

Package Form	Embossed taping
Package Quantity	2000pcs
Package Orientation	E2 (When the reek is held with the left hand and the tape is drawn out with the right hand, the No.1 pin of the product faces the lower left direction.)

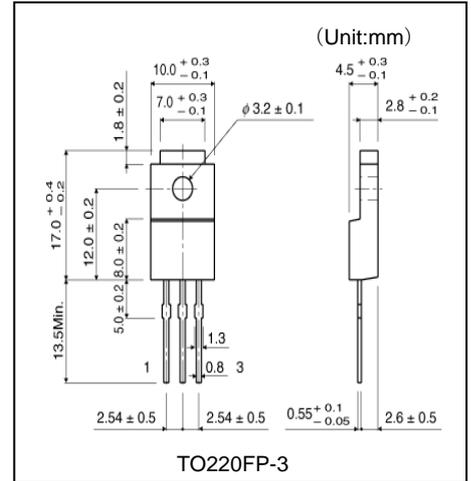
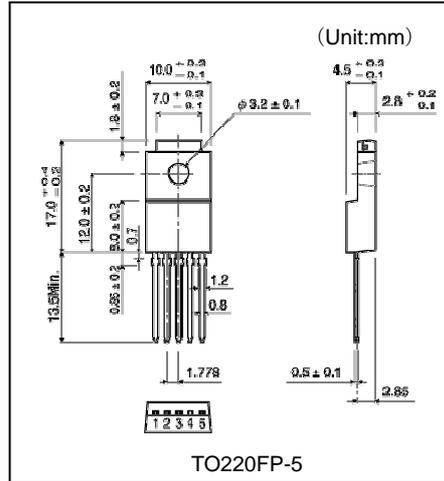
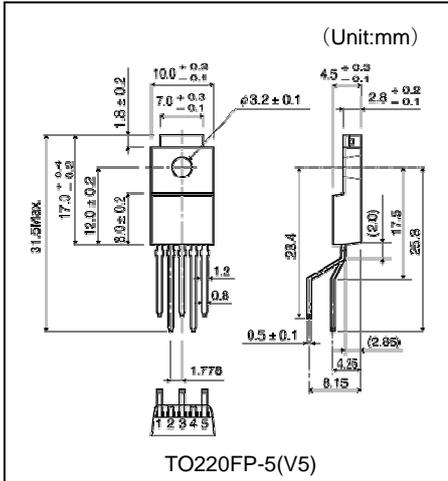
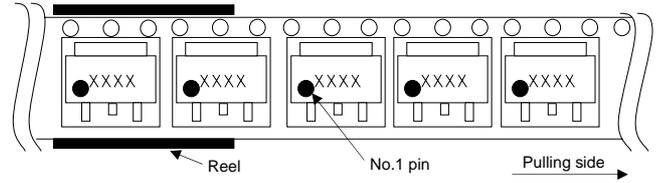

<Package Specification>TO220FP-5 (V5)

Package Form	Container tube
Package Quantity	500pcs
Package Orientation	The product orientation in each container tube is constant.

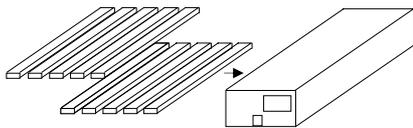

*Please make orders in multiples of the package quantity.

<Package Specification>TO220FP-5

Package Form	Container tube
Package Quantity	500pcs
Package Orientation	The product orientation in each container tube is constant.

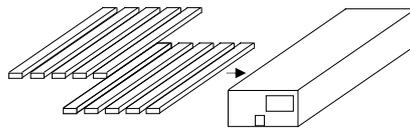

*Please make orders in multiples of the package quantity.

<Package Specification>TO220FP-3

Package Form	Container tube
Package Quantity	500pcs
Package Orientation	The product orientation in each container tube is constant.

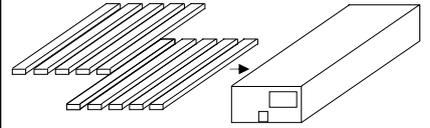

*Please make orders in multiples of the package quantity.

Notes

- No technical content pages of this document may be reproduced in any form or transmitted by any means without prior permission of ROHM CO.,LTD.
- The contents described herein are subject to change without notice. The specifications for the product described in this document are for reference only. Upon actual use, therefore, please request that specifications to be separately delivered.
- Application circuit diagrams and circuit constants contained herein are shown as examples of standard use and operation. Please pay careful attention to the peripheral conditions when designing circuits and deciding upon circuit constants in the set.
- Any data, including, but not limited to application circuit diagrams information, described herein are intended only as illustrations of such devices and not as the specifications for such devices. ROHM CO.,LTD. disclaims any warranty that any use of such devices shall be free from infringement of any third party's intellectual property rights or other proprietary rights, and further, assumes no liability of whatsoever nature in the event of any such infringement, or arising from or connected with or related to the use of such devices.
- Upon the sale of any such devices, other than for buyer's right to use such devices itself, resell or otherwise dispose of the same, no express or implied right or license to practice or commercially exploit any intellectual property rights or other proprietary rights owned or controlled by
- ROHM CO., LTD. is granted to any such buyer.
- Products listed in this document are no antiradiation design.

The products listed in this document are designed to be used with ordinary electronic equipment or devices (such as audio visual equipment, office-automation equipment, communications devices, electrical appliances and electronic toys).

Should you intend to use these products with equipment or devices which require an extremely high level of reliability and the malfunction of which would directly endanger human life (such as medical instruments, transportation equipment, aerospace machinery, nuclear-reactor controllers, fuel controllers and other safety devices), please be sure to consult with our sales representative in advance.

It is our top priority to supply products with the utmost quality and reliability. However, there is always a chance of failure due to unexpected factors. Therefore, please take into account the derating characteristics and allow for sufficient safety features, such as extra margin, anti-flammability, and fail-safe measures when designing in order to prevent possible accidents that may result in bodily harm or fire caused by component failure. ROHM cannot be held responsible for any damages arising from the use of the products under conditions out of the range of the specifications or due to non-compliance with the NOTES specified in this catalog.

Thank you for your accessing to ROHM product informations.

More detail product informations and catalogs are available, please contact your nearest sales office.

ROHM Customer Support System

THE AMERICAS / EUROPE / ASIA / JAPAN

www.rohm.com

Contact us : webmaster@rohm.co.jp