

Structure Silicon Monolithic Integrated Circuit

Product Name Capacitive Sensor Controller for Cellular Phone

Product No. **BU21010MUV**

Features 8 sensor inputs.
 4 LED outputs.
 Gesture detection with 4ch sensor.
 Push and hold detection
 Analog supply voltage is 2.5 – 3.3V, Digital I/F voltage is 1.7 – 3.3V
 2-wire serial interface.
 Integrated 10bit AD converter, CR clock.

○Absolute Maximum Ratings (Ta=25[°C])

Parameter	Symbol	Rating	Unit	Notes
Supply voltage	AVDD	-0.3~4.5	V	
	DVDD	-0.3~4.5	V	
Input voltage	V _{AIN}	-0.3~AVDD + 0.3	V	
	V _{DIN}	-0.3~DVDD + 0.3	V	
Storage temperature range	T _{stg}	-55~125	°C	
Operating temperature range	T _{opr}	-40~85	°C	
Power dissipation	P _d	215 ^(*)	mW	

(*1) This is the power dissipation per IC unit. Reduce to 2.15 mW /°C when Ta = 25°C or above.

○Operating condition (Ta=25[°C])

Parameter	Symbol	Rating			Unit	Notes
		Min.	Typ.	Max.		
Supply voltage	AVDD	2.5	3.0	3.3	V	
	DVDD	1.7	3.0	3.3	V	

This chip is not designed to protect itself against radioactive rays.

Status of this document

The Japanese version of this document is the formal specification. A customer may use this translation version only for a reference to help reading the formal version. If there are any differences in translation version of this document, formal version takes priority.

○Electrical characteristics (Unless otherwise noted Ta=25[°C], GND=0[V])

Parameter	Symbol	Rating			Unit	Notes	
		Min.	Typ.	Max.			
DC characteristic							
Input "H" voltage	V_{IHIO}	DVDD x 0.8	-	DVDD + 0.3	V		
Input "L" voltage	V_{ILIO}	GND - 0.3	-	DVDD x 0.2	V		
Output "H" voltage	V_{OHIO}	DVDD - 0.7	-	DVDD	V	$I_{OH} = -2[mA]$. Overshoot is excluded.	
Output "L" voltage	V_{OLLED}	GND	-	0.5	V	$I_{OL} = 8[mA]$. Undershoot is excluded. LED output. $I_{OL} = 3[mA]$ Undershoot is excluded. SDA application. $I_{OL} = 2[mA]$. Undershoot is excluded. INT application.	
	V_{OLSDA}	GND	-	0.5			DVDD > 2[V]
				DVDD x 0.3			DVDD ≤ 2[V]
V_{OLINT}	GND	-	0.5				
Input leakage current	I_{IZ}	-1	-	1	μA		
Hi-Z leakage current	I_{OZ}	-1	-	1	μA		
Standby current	I_{ST}	-	-	2	μA	Shutdown (SDN="L")	
Operating current	I_{BD}	-	300	-	μA		

○Block diagram

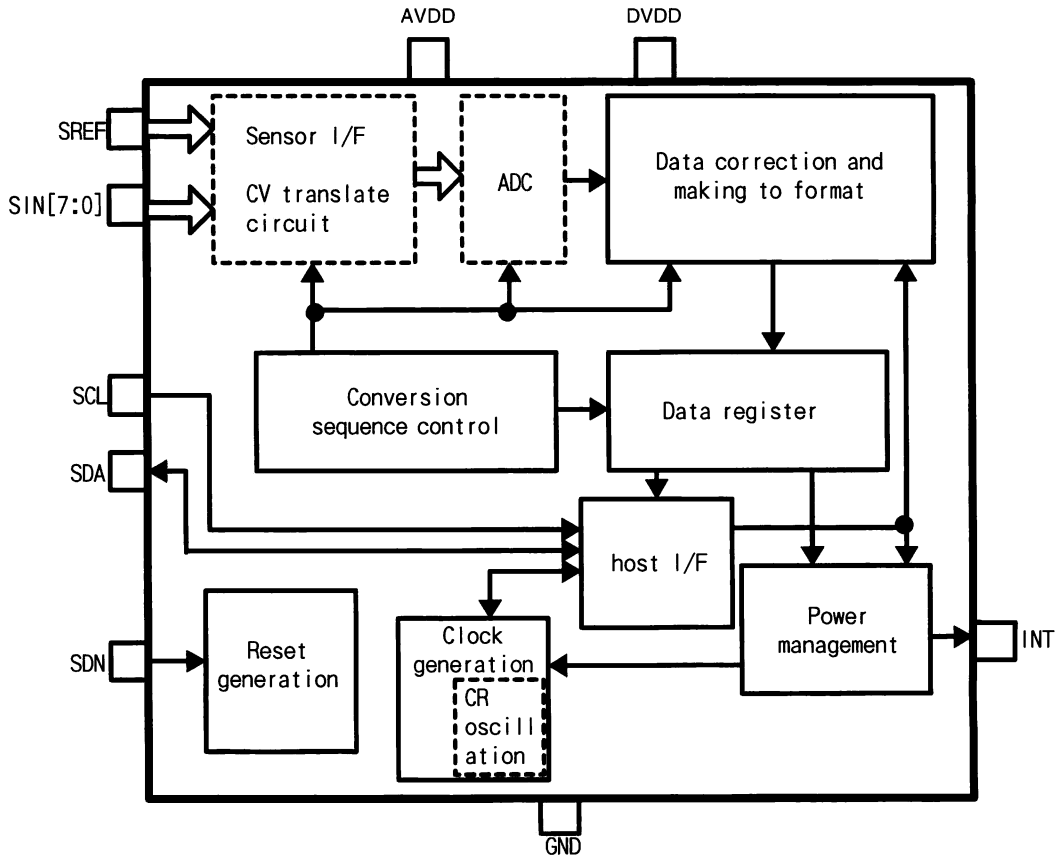

○External measure and View

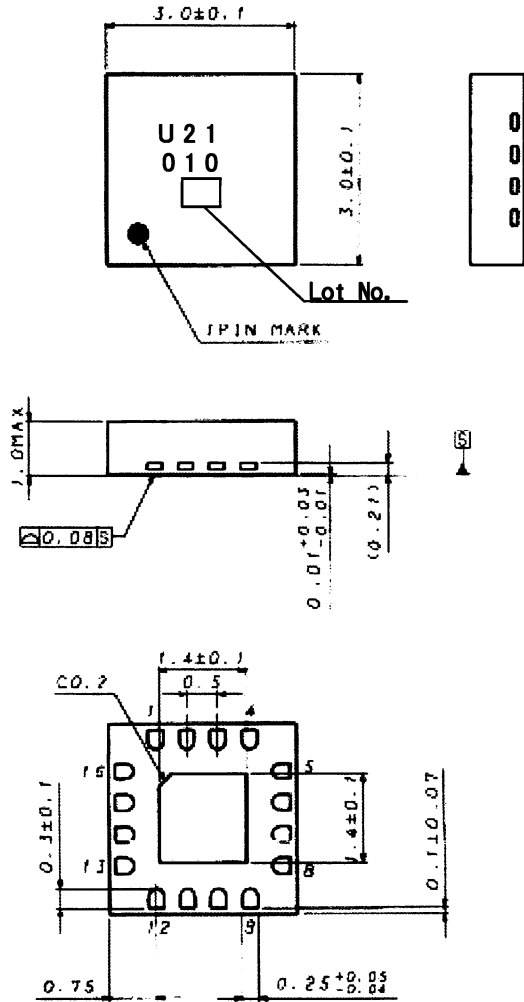

(Unit : mm)

VQFN016V3030

○Pin description

Pin No.	Pin Name	Function
1	SDA	Communication data sending and receiving
2	SCL	Communication synchronous clock input
3	INT	Output of interrupt
4	SDN	Shutdown input
5	SREF	Reference capacitor input
6	SIN0	Sensor input 0
7	GND	Analog and Digital Ground
8	SIN1/LED0	Sensor input 1 / LED control output 0
9	SIN2	Sensor input 2
10	SIN3/LED1	Sensor input 3 / LED control output 1
11	SIN4	Sensor input 4
12	SIN5/LED2	Sensor input 5 / LED control output 2
13	SIN6	Sensor input 6
14	SIN7/LED3	Sensor input 7 / LED control output 3
15	AVDD	Analog block Power supply
16	DVDD	Digital block Power supply

○Cautions on use

(1) Absolute Maximum Ratings

An excess in the absolute maximum ratings, such as supply voltage, temperature range of operating conditions, etc., can break down devices, thus making impossible to identify breaking mode such as a short circuit or an open circuit. If any special mode exceeding the absolute maximum ratings is assumed, consideration should be given to take physical safety measures including the use of fuses, etc.

(2) Operating conditions

These conditions represent a range within which characteristics can be provided approximately as expected. The electrical characteristics are guaranteed under the conditions of each parameter.

(3) Reverse connection of power supply connector

The reverse connection of power supply connector can break down ICs. Take protective measures against the breakdown due to the reverse connection, such as mounting an external diode between the power supply and the IC's power supply terminal.

(4) Power supply line

Design PCB pattern to provide low impedance for the wiring between the power supply and the GND lines. In this regard, for the digital block power supply and the analog block power supply, even though these power supplies has the same level of potential, separate the power supply pattern for the digital block from that for the analog block, thus suppressing the diffraction of digital noises to the analog block power supply resulting from impedance common to the wiring patterns. For the GND line, give consideration to design the patterns in a similar manner.

Furthermore, for all power supply terminals to ICs, mount a capacitor between the power supply and the GND terminal. At the same time, in order to use an electrolytic capacitor, thoroughly check to be sure the characteristics of the capacitor to be used present no problem including the occurrence of capacity dropout at a low temperature, thus determining the constant.

(5) GND voltage

Make setting of the potential of the GND terminal so that it will be maintained at the minimum in any operating state. Furthermore, check to be sure no terminals are at a potential lower than the GND voltage including an actual electric transient.

(6) Short circuit between terminals and erroneous mounting

In order to mount ICs on a set PCB, pay thorough attention to the direction and offset of the ICs. Erroneous mounting can break down the ICs. Furthermore, if a short circuit occurs due to foreign matters entering between terminals or between the terminal and the power supply or the GND terminal, the ICs can break down.

(7) Operation in strong electromagnetic field

Be noted that using ICs in the strong electromagnetic field can malfunction them.

(8) Inspection with set PCB

On the inspection with the set PCB, if a capacitor is connected to a low-impedance IC terminal, the IC can suffer stress. Therefore, be sure to discharge from the set PCB by each process. Furthermore, in order to mount or dismount the set PCB to/from the jig for the inspection process, be sure to turn OFF the power supply and then mount the set PCB to the jig. After the completion of the inspection, be sure to turn OFF the power supply and then dismount it from the jig. In addition, for protection against static electricity, establish a ground for the assembly process and pay thorough attention to the transportation and the storage of the set PCB.

(9) Input terminals

In terms of the construction of IC, parasitic elements are inevitably formed in relation to potential. The operation of the parasitic element can cause interference with circuit operation, thus resulting in a malfunction and then breakdown of the input terminal. Therefore, pay thorough attention not to handle the input terminals, such as to apply to the input terminals a voltage lower than the GND respectively, so that any parasitic element will operate. Furthermore, do not apply a voltage to the input terminals when no power supply voltage is applied to the IC. In addition, even if the power supply voltage is applied, apply to the input terminals a voltage lower than the power supply voltage or within the guaranteed value of electrical characteristics.

(10) Ground wiring pattern

If small-signal GND and large-current GND are provided, it will be recommended to separate the large-current GND pattern from the small-signal GND pattern and establish a single ground at the reference point of the set PCB so that resistance to the wiring pattern and voltage fluctuations due to a large current will cause no fluctuations in voltages of the small-signal GND. Pay attention not to cause fluctuations in the GND wiring pattern of external parts as well.

(11) External capacitor

In order to use a ceramic capacitor as the external capacitor, determine the constant with consideration given to a degradation in the nominal capacitance due to DC bias and changes in the capacitance due to temperature, etc.

(12) Rush current

The IC with some power supplies has a capable of rush current due to procedure and delay at power-on. Pay attention to the capacitance of the coupling condensers and the wiring pattern width and routing of the power supply and the GND lines.

(13) Others

In case of use this LSI, please peruse some other detail documents, we called, Technical note, Functional description, Application note.

Notes

- No technical content pages of this document may be reproduced in any form or transmitted by any means without prior permission of ROHM CO.,LTD.
- The contents described herein are subject to change without notice. The specifications for the product described in this document are for reference only. Upon actual use, therefore, please request that specifications to be separately delivered.
- Application circuit diagrams and circuit constants contained herein are shown as examples of standard use and operation. Please pay careful attention to the peripheral conditions when designing circuits and deciding upon circuit constants in the set.
- Any data, including, but not limited to application circuit diagrams information, described herein are intended only as illustrations of such devices and not as the specifications for such devices. ROHM CO.,LTD. disclaims any warranty that any use of such devices shall be free from infringement of any third party's intellectual property rights or other proprietary rights, and further, assumes no liability of whatsoever nature in the event of any such infringement, or arising from or connected with or related to the use of such devices.
- Upon the sale of any such devices, other than for buyer's right to use such devices itself, resell or otherwise dispose of the same, no express or implied right or license to practice or commercially exploit any intellectual property rights or other proprietary rights owned or controlled by
- ROHM CO., LTD. is granted to any such buyer.
- Products listed in this document are no antiradiation design.

The products listed in this document are designed to be used with ordinary electronic equipment or devices (such as audio visual equipment, office-automation equipment, communications devices, electrical appliances and electronic toys).

Should you intend to use these products with equipment or devices which require an extremely high level of reliability and the malfunction of which would directly endanger human life (such as medical instruments, transportation equipment, aerospace machinery, nuclear-reactor controllers, fuel controllers and other safety devices), please be sure to consult with our sales representative in advance.

It is our top priority to supply products with the utmost quality and reliability. However, there is always a chance of failure due to unexpected factors. Therefore, please take into account the derating characteristics and allow for sufficient safety features, such as extra margin, anti-flammability, and fail-safe measures when designing in order to prevent possible accidents that may result in bodily harm or fire caused by component failure. ROHM cannot be held responsible for any damages arising from the use of the products under conditions out of the range of the specifications or due to non-compliance with the NOTES specified in this catalog.

Thank you for your accessing to ROHM product informations.

More detail product informations and catalogs are available, please contact your nearest sales office.

ROHM Customer Support System

THE AMERICAS / EUROPE / ASIA / JAPAN

www.rohm.com

Contact us : webmaster@rohm.co.jp