

●Description

The BP5220A, BP5221A, BP5222A, are DC / DC converters that use a pulse width modulation (PWM) system. They contain control circuits, switching devices, rectifiers, and coils, and operate by only connecting an I / O smoothing capacitor. With a high efficiency of power conversion, the modules are available in stand-alone 9-pin SIP packages with no heat sink required. They can be applied to various purposes by fine-adjusting the output voltage and switching on and off. With a wide range of input voltage, the modules are best suited for obtaining a stable local power supply from a main power supply with a large voltage variation.

●Applications

Power supplies for copiers, personal computers, facsimiles, AV equipment, measuring instruments, vending machines, security device, registers, industrial equipment, and maintenance tools

●Features

- 1) Wide range of input voltage.
- 2) High power conversion efficiency.
- 3) Built-in output ON / OFF switch.
- 4) Applicable to various purposes by fine-adjusting the output voltage.
- 5) Small number of external components required.
- 6) Heat sink unnecessary.
- 7) Compact package.

BP5220A / BP5221A / BP5222A : SIP9

●Dimensions (Unit : mm)

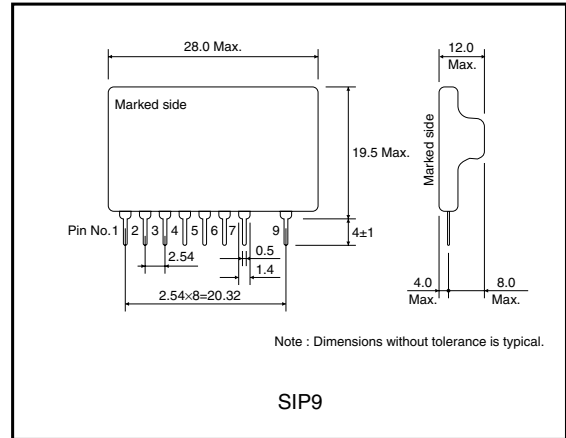

●List of the series

	BP5220A	BP5221A	BP5222A	Unit
Input voltage	8 to 38	8 to 38	15 to 38	V
Output voltage	5	5	12	V
Output current	1	0.5	0.5	A
Power conversion efficiency	85 ($V_{IN}=15V$)	84 ($V_{IN}=15V$)	90 ($V_{IN}=20V$)	%

●Absolute maximum ratings ($T_a=25^\circ C$)

Parameter	Symbol	Limits			Unit
		BP5220A	BP5221A	BP5222A	
Input voltage	V_{IN}	8 to 38	8 to 38	15 to 38	V
Output current	I_o	1	0.5	0.5	A
Operating temperature range	T_{opr}	-20 to +70			$^\circ C$
Storage temperature range	T_{stg}	-25 to +80			$^\circ C$

● Block diagram

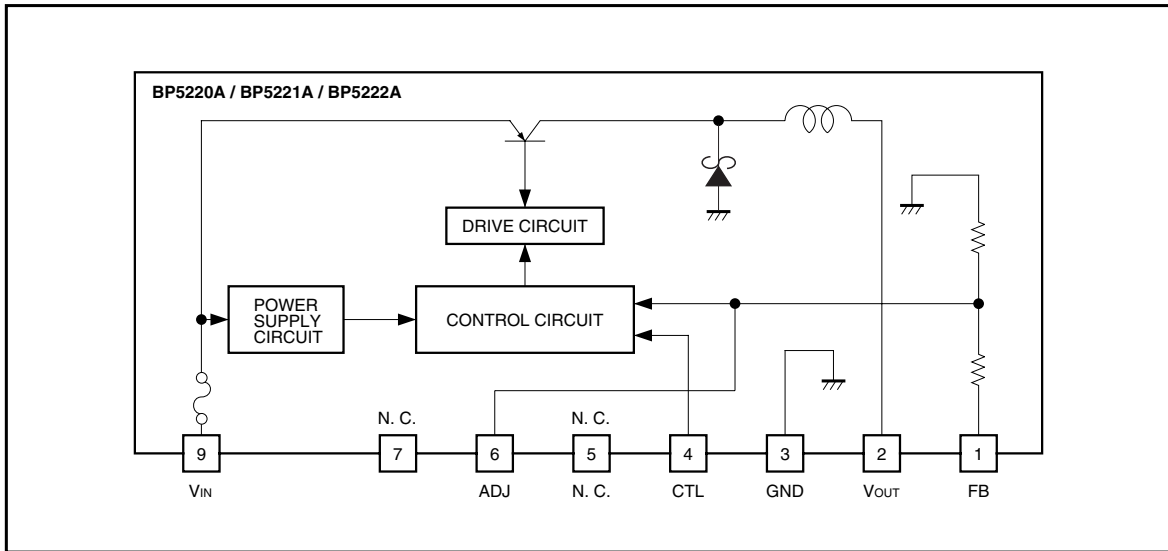

● Electrical characteristics

BP5220A (Unless otherwise noted : $V_{IN}=15V$, $I_o=0.5A$, $SW=1$, $T_a=25^{\circ}C$)

Parameter	Symbol	Min.	Typ.	Max.	Unit	Conditions
Input voltage	V_{IN}	8	–	38	V	
Output voltage	V_o	4.75	5	5.25	V	
Output current	I_o	–	–	1	A	$V_{IN}<30V$ *1
Line regulation	ΔV_{O1}	–	27	80	mV	$V_{IN}=8V$ to 38V
Load regulation	ΔV_{O2}	–	13	80	mV	$I_o=0.1A$ to 1A
Output ripple voltage	v_r	–	22	70	mV _{PP}	*2
Power conversion efficiency	η	75	85	–	%	$I_o=1A$
Switching frequency	f_{sw}	–	190	–	kHz	
CTL pin ON resistance	R_{ON}	–	–	4.7	k Ω	$V_o>4.75V$
CTL pin OFF resistance	R_{OFF}	200	–	–	k Ω	$V_o<0.1V$, $SW=2$

*1 Derating required according to the input voltage and ambient temperature.

*2 Pulse noise not included.

BP5221A (Unless otherwise noted : $V_{IN}=15V$, $I_o=0.25A$, $SW=1$, $T_a=25^{\circ}C$)

Parameter	Symbol	Min.	Typ.	Max.	Unit	Conditions
Input voltage	V_{IN}	8	–	38	V	
Output voltage	V_o	4.75	5	5.25	V	
Output current	I_o	–	–	0.5	A	*1
Line regulation	ΔV_{O1}	–	13	50	mV	$V_{IN}=8V$ to 38V
Load regulation	ΔV_{O2}	–	3	50	mV	$I_o=0.05A$ to 0.5A
Output ripple voltage	v_r	–	25	70	mV _{PP}	*2
Power conversion efficiency	η	70	84	–	%	$I_o=1A$
Switching frequency	f_{sw}	–	190	–	kHz	
CTL pin ON resistance	R_{ON}	–	–	4.7	k Ω	$V_o>4.75V$
CTL pin OFF resistance	R_{OFF}	200	–	–	k Ω	$V_o<0.1V$, $SW=2$

*1 Derating required according to the input voltage and ambient temperature.

*2 Pulse noise not included.

BP5222A (Unless otherwise noted : $V_{IN}=20V$, $I_o=0.25A$, $SW=1$, $T_a=25^{\circ}C$)

Parameter	Symbol	Min.	Typ.	Max.	Unit	Conditions
Input voltage	V_{IN}	15	–	38	V	
Output voltage	V_o	11.2	12	12.8	V	
Output current	I_o	–	–	0.5	A	*1
Line regulation	ΔV_{O1}	–	22	50	mV	$V_{IN}=15V$ to $38V$
Load regulation	ΔV_{O2}	–	18	50	mV	$I_o=0.05A$ to $0.5A$
Output ripple voltage	v_r	–	29	70	mV _{PP}	*2
Power conversion efficiency	η	75	90	–	%	$I_o=0.5A$
Switching frequency	f_{sw}	–	190	–	kHz	*2
CTL pin ON resistance	R_{ON}	–	–	4.7	k Ω	$V_o>11.2V$
CTL pin OFF resistance	R_{OFF}	200	–	–	k Ω	$V_o<0.1V$, $SW=2$

*1 Derating required according to the input voltage and ambient temperature.

*2 Pulse noise not included.

● Measurement circuit

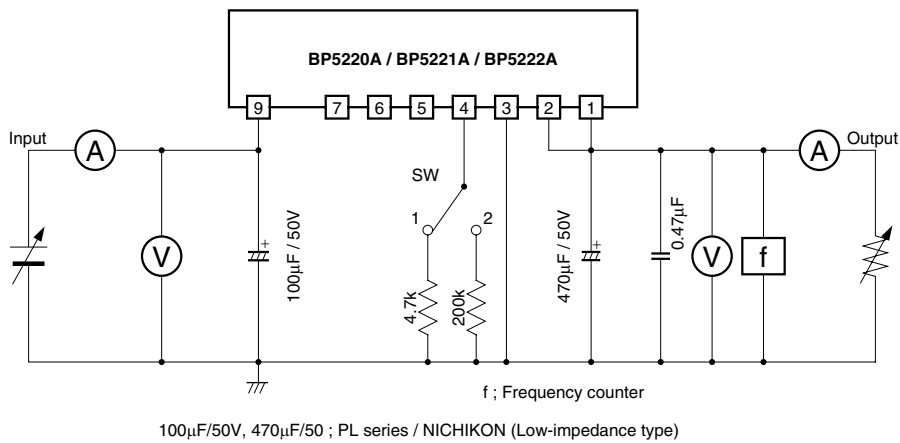

100µF/50V, 470µF/50 ; PL series / NICHIKON (Low-impedance type)

Fig.1

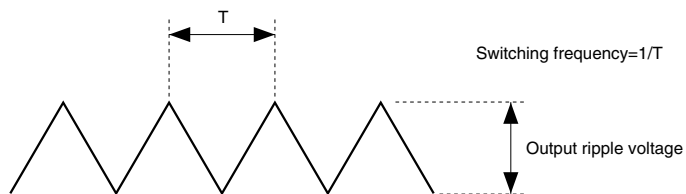

Note) that output ripple voltage depends on the type and characteristics of the output capacitor.

●Circuit operation

- (1) The basic application examples are shown in Fig.2. The externally installed parts are only the input and output smoothing capacitors.
- (2) Switching on and off the output voltage is allowed. The output can be switched off by making pin 4 to be open (high impedance). (See Fig.3)
- (3) Fine adjustment of the output voltage is allowed. The fine adjustment of output voltage can be performed from pin 6 via the resistor by connecting the output terminal (pin 2) or GND. (See application example 3)

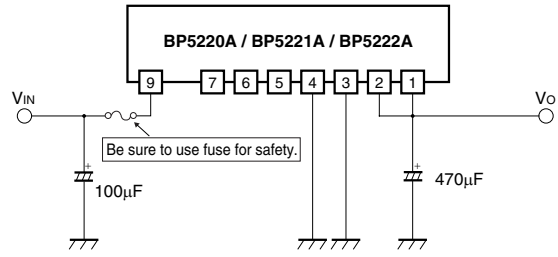

Fig.2

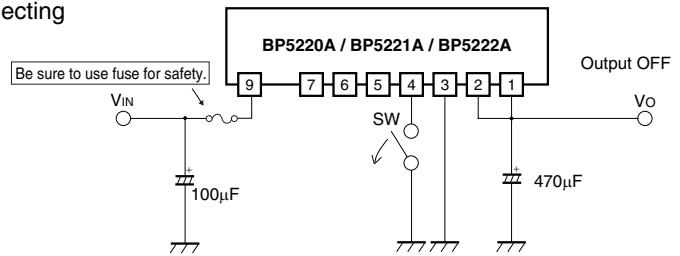

Fig.3

●Application example

Application example 1 : DC / DC converter with a protection circuit

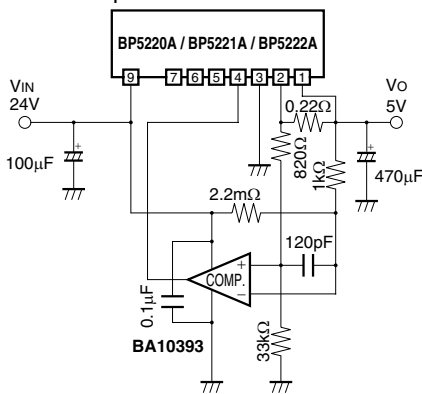

Fig.4

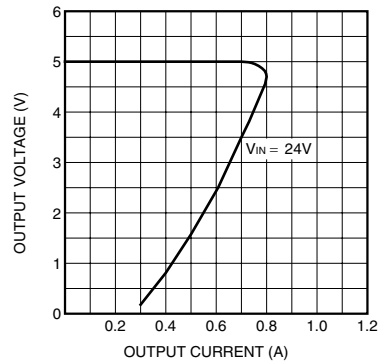

Fig.5

* A resistor to secure the rise of output at power on. The resistance to be selected depends on the input voltage. This is a standard application. Because the control current fluctuates with variations in circuits and components, set the control current by adding a sufficient margin to the normal current level.

Application example 2 : Output ON / OFF control

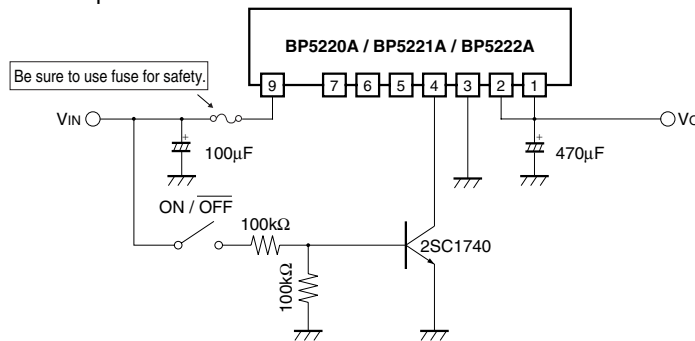

Fig.6

Application example 3 : Output voltage fine adjustment

(1) When reducing the output voltage

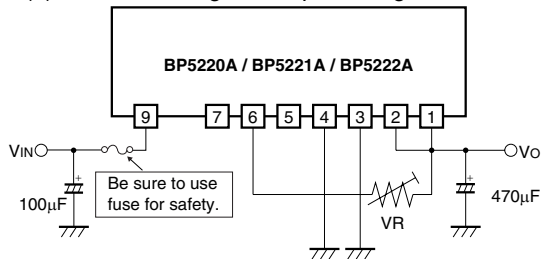

Fig.7

(2) When increasing the output voltage

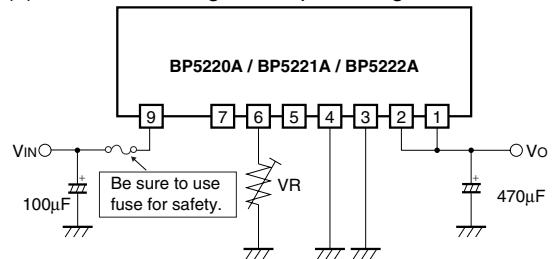

Fig.8

VR value setting equations (The output voltage after adjustment is denoted Vo.)

(1) When reducing the output voltage

BP5220A / BP5221A $R = (V_o - 1.281) / (0.0278 - 0.00556V_o)$ (k Ω)
 BP5222A $R = (V_o - 1.281) / (0.1196 - 0.01V_o)$ (k Ω)

(2) When increasing the output voltage

BP5220A / BP5221A $R = 11160 / (48.4V_o - 242)$ (k Ω)
 BP5222A $R = 1200 / (9.368V_o - 112)$ (k Ω)

To make full use of the ability of the module products, we recommended the output voltage be adjusted within $\pm 20\%$ of the output voltage rating. When the output voltage is increased by 20%, for instance, the minimum input voltage is also increased by 20%.

(Example : When the output voltage is changed from 5V to 6V in the BP5220A, the minimum input voltage is changed from 8V to 9.6V)

Application example 4 : Slow start

The slow start circuit mitigates the pulse load on the internal switching transistor when input voltage is applied, and rises the output voltage gradually by starting the switching operation slowly.

This application is useful for preventing the malfunction of an external protection circuit due to a rush current, and can serve as a countermeasure against the operation outside the safe operation range.

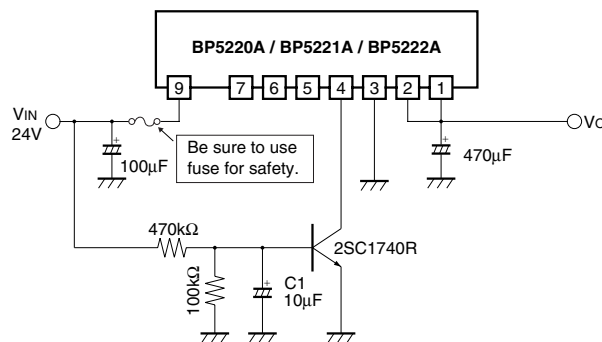

Fig.9

C1 is a slow-start capacitor for mitigating the over rush current that flows into the modules when the switch is turned on.

● **Operation notes**

- (1) No circuit is installed in the modules to protect against over output currents. Take physical safety measures such as fusing if short-circuit loading is probable.
- (2) The output current should be reduced according to an increase in the input voltage or ambient temperature. Use the modules within the derating curve range.
- (3) A large rush current may flow in the module when the input voltage is applied or the output ON / OFF is controlled with pin 4 without a capacitor such as C1 in application 4. Operating within the safe operation ranges shown in Figs.12, 15, and 18.
The safe operation range is determined by the safe operation range of the internal switching transistor. The amount of rush current depends on the output impedance of the input power supply and capacitors connected to the module outputs. The pulse load on the internal switching transistor at the start of operation can be reduced by using the protection circuit of application 1 or the slow start circuit of application 4.
- (4) Pins 5 and 7 are no connected.
- (5) Smoothing electrolytic capacitor is necessary for I/O external components. Please use a capacitor equivalent to the recommended one.
- (6) Please put an I/O smoothing capacitor near this module. Output ripple voltage may be larger or output voltage may not be stable.

● **Electrical characteristics curves**

BP5220A

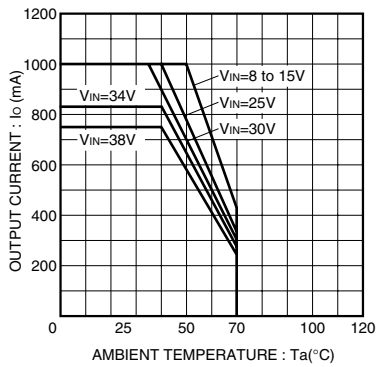

Fig.10 Derating curve

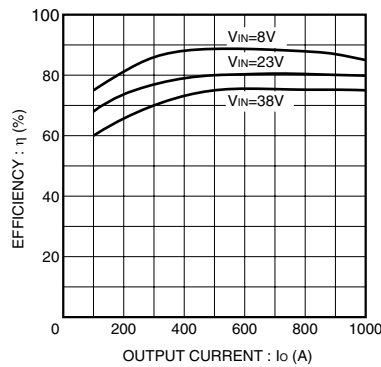

Fig.11 Efficiency

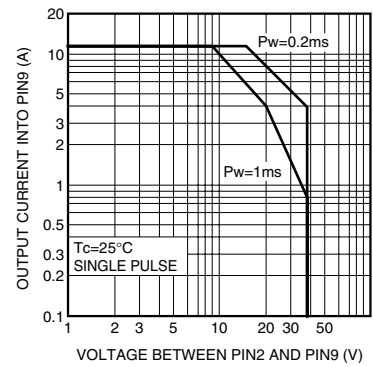

Fig.12 Safety operation range

BP5221A

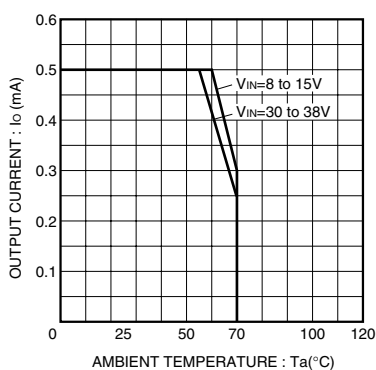

Fig.13 Derating curve

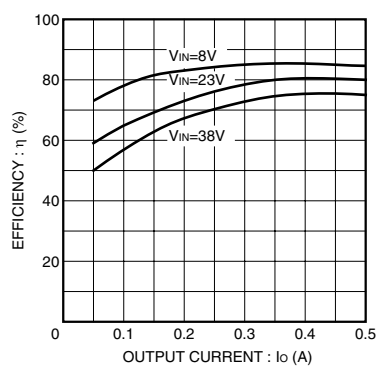

Fig.14 Efficiency

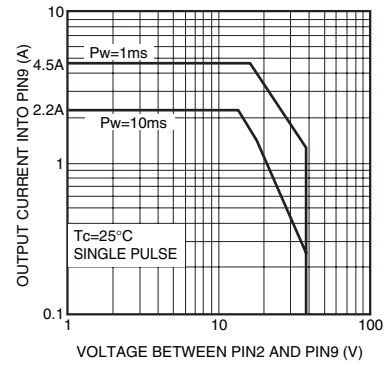

Fig.15 Safety operation range

BP5222A

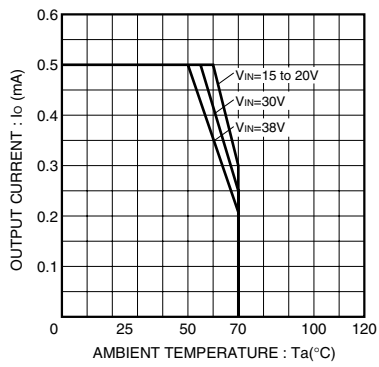

Fig.16 Derating curve

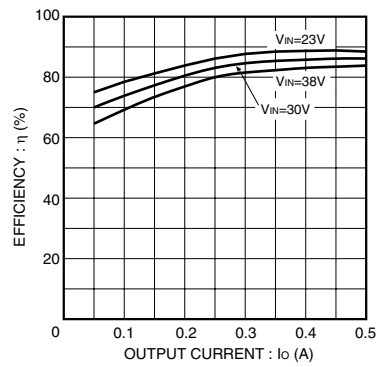

Fig.17 Efficiency

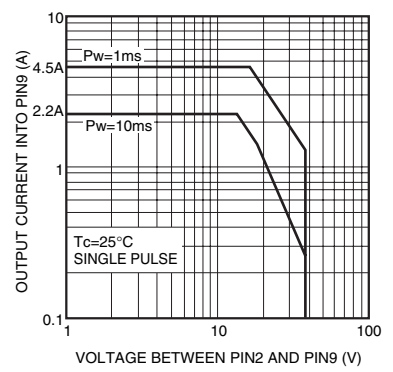

Fig.18 Safety operation range

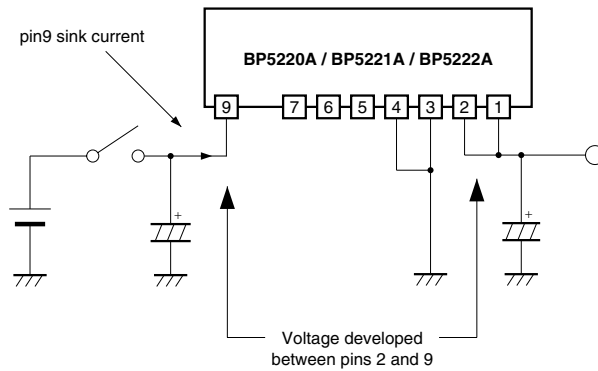

Fig.19 ASO measurement circuit

Power Module Usage Precautions

Safety Precautions

- 1) The products are designed and manufactured for use in ordinary electronic equipment (i.e. AV/OA/telecommunication/amusement equipment, home appliances). Please consult with the Company's (ROHM) sales staff if intended for use in devices requiring high reliability (e.g. medical/transport/aircraft/spacecraft equipment, nuclear power/fuel controllers, automotive/safety devices) and whose malfunction may result in injury or death. In this case, failsafe measures must be taken, including the following:
 - [a] Installation of protection circuits in order to improve system safety
 - [b] Incorporation of redundant circuits in the case of single-circuit failure
- 2) The products are designed for use under normal conditions. Application in special environments can cause a deterioration in product performance. Therefore, verification and confirmation of product performance, prior to use, is recommended. The following environments are considered to be 'special':
 - [a] Outdoors, exposed to direct sunlight or dust
 - [b] In contact with liquids, such as water, oils, chemicals, or organic solvents
 - [c] In areas where exposure to the sea air or corrosive gases (i.e. Cl₂, H₂S, NH₃, SO₂, NO₂) can occur
 - [d] In places where the products may be in contact with static electricity or electromagnetic waves
 - [e] In proximity to heat-producing items, plastic cords, or flammable materials
 - [f] In contact with sealing or coating products, such as resin
 - [g] In contact with unclean solder or exposed to water or water-soluble cleaning agents used after soldering
 - [h] In areas where dew condensation occurs
- 3) The products are not designed to be radiation resistant
- 4) The Company is not responsible for any problems resulting from use of the products under conditions not recommended herein.
- 5) The Company should be notified of any product safety issues. Moreover, product safety issues should be periodically monitored by the customer.

Application Notes

- 1) A sufficient margin must be allowed if changes are made to the peripheral circuit due to variations in the inherent tolerances of the external components as well as transient and static characteristics. In addition, please be aware that the Company has not conducted investigations on whether or not particular changes in the example application circuits would result in patent infringement.
- 2) The application examples, their constants, and other types of information contained herein are applicable only when the products are used in accordance with standard methods. Therefore, if mass production is intended, sufficient consideration to external conditions must be made.

Notes Regarding Industrial Property

- 1) The specifications included herein contain information related to the Company's industrial property. Their use other than pertaining to the relevant products is forbidden. Duplication and/or disclosure to a third party without express written permission is strictly prohibited.
- 2) Product information and data, including application examples, contained in the specifications are for reference purposes only; the Company does not guarantee the industrial/intellectual property rights or any other rights of a third party. Accordingly, the Company shall not bear responsibility for:
 - [a] Infringement of the intellectual property rights of a third party
 - [b] Problems arising from the use of the products listed herein
- 3) The Company prohibits the purchaser from exercising or using the intellectual/industrial property rights or any rights belonging to or are controlled by the Company, other than the right to use, sell, or dispose of the products.

Notes

- No technical content pages of this document may be reproduced in any form or transmitted by any means without prior permission of ROHM CO.,LTD.
- The contents described herein are subject to change without notice. The specifications for the product described in this document are for reference only. Upon actual use, therefore, please request that specifications to be separately delivered.
- Application circuit diagrams and circuit constants contained herein are shown as examples of standard use and operation. Please pay careful attention to the peripheral conditions when designing circuits and deciding upon circuit constants in the set.
- Any data, including, but not limited to application circuit diagrams information, described herein are intended only as illustrations of such devices and not as the specifications for such devices. ROHM CO.,LTD. disclaims any warranty that any use of such devices shall be free from infringement of any third party's intellectual property rights or other proprietary rights, and further, assumes no liability of whatsoever nature in the event of any such infringement, or arising from or connected with or related to the use of such devices.
- Upon the sale of any such devices, other than for buyer's right to use such devices itself, resell or otherwise dispose of the same, no express or implied right or license to practice or commercially exploit any intellectual property rights or other proprietary rights owned or controlled by
- ROHM CO., LTD. is granted to any such buyer.
- Products listed in this document are no antiradiation design.

The products listed in this document are designed to be used with ordinary electronic equipment or devices (such as audio visual equipment, office-automation equipment, communications devices, electrical appliances and electronic toys).

Should you intend to use these products with equipment or devices which require an extremely high level of reliability and the malfunction of which would directly endanger human life (such as medical instruments, transportation equipment, aerospace machinery, nuclear-reactor controllers, fuel controllers and other safety devices), please be sure to consult with our sales representative in advance.

About Export Control Order in Japan

Products described herein are the objects of controlled goods in Annex 1 (Item 16) of Export Trade Control Order in Japan.

In case of export from Japan, please confirm if it applies to "objective" criteria or an "informed" (by MITI clause) on the basis of "catch all controls for Non-Proliferation of Weapons of Mass Destruction.