



## Atmel MSL2021/23/24 LED Drivers: Efficient Power Management for High CRI LED Lamps

Designing high-performance light fixtures calls for multi-color, multi string LEDs that achieve a high color rendering index (CRI) and the desired correlated color temperature (CCT). High CRI light engine design involves two-color LED systems, such as white and color (red/amber) LEDs. Maintaining uniform CCT over the entire operating temperature range of the light fixture can be challenging, since white and color LEDs have different temperature coefficients. Other challenges include tackling power management, dimming range and bill of materials (BOM) cost for multi-string LED systems.

For the most efficient designs, look no further than the new Atmel® MSL2021/23/24 family of solid state lighting (SSL) LED drivers. These are unique drivers from Atmel developed with a patented adaptive power control scheme, as well as compensation circuitry to resolve issues around the non-linear characteristics of LEDs. By comparison, competitive devices require an external microcontroller and firmware to address temperature compensation, making them a more complex and costly proposition.

The MSL2021/23/24 family of two-channel LED drivers is designed for CRI LED lamps. The devices drive one dominant LED string and one color LED string to achieve the target CCT coordinate and to replicate the color spectrum to attain a high CRI value. The family consists of three devices:

- The MSL2021 features integrated CCT compensation circuitry
- The MSL2023 and MSL2024 facilitate development with Atmel's general-purpose and communication microcontrollers

### MSL2021: Integrated Temperature Compensation

The MSL2021 is the first LED driver to offer integrated temperature compensation for the color LED string, simplifying the design of high CRI LED lamps. With integrated temperature compensation, you can maintain your desired CCT over the entire LED lamp temperature range. With the device's look-up table, programmed in its integrated EEPROM, you can vary the LED string currents to follow the desired CCT compensation curve.

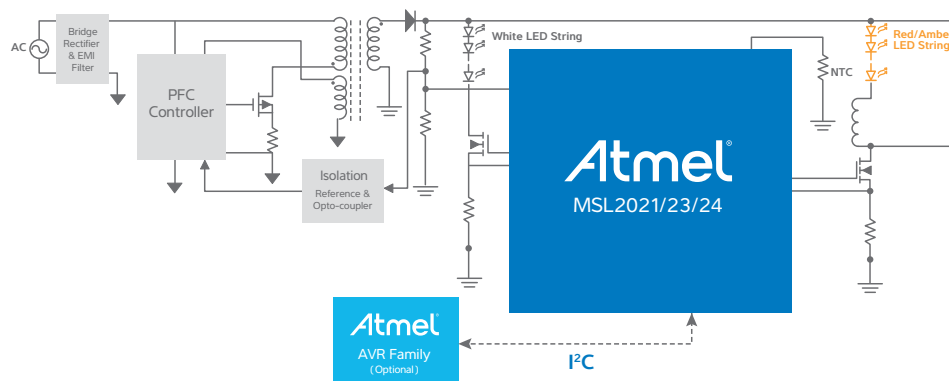

This diagram depicts a typical application using the Atmel MSL2021/23/24 LED drivers, which support the widest power levels.



# Atmel MSL2021/23/24 LED Drivers: Efficient Power Management for High CRI LED Lamps

## MSL2023: I<sup>2</sup>C Serial Port

The MSL2023 is controlled and programmed by an I<sup>2</sup>C serial port to interface and utilize internal pulse width modulation (PWM) generators to drive both LED strings. The device also interfaces with microcontrollers via its I<sup>2</sup>C interface.

## MSL2024: Two PWM Inputs

The MSL2024 offers two PWM inputs to directly control the PWM dimming for each LED string. This architecture allows for easy implementation with any microcontroller, supporting dimming frequency from 60Hz to 10KHz.

## Highest System Power Efficiency

For the highest system power efficiency, the MSL2021/23/24 devices feature a patent-pending adaptive power control scheme that adaptively controls the headroom on the output of a single-stage AC/DC power factor correction (PFC) or DC/DC power supply. The devices also feature an internal soft start capability that sequences the turn-on of the strings to avoid any artifacts, such as high inrush currents and flashing.

With one linear current control of dominant LED string, you'll benefit from high current accuracy and a wide dimming range. The LED driver family includes a switching controller to drive the color LED string. Using I<sup>2</sup>C control, the MSL2021/23/24 devices allow for peak current adjustment for both the LED strings.

## Connectivity

To help you create smart, connected lighting units, the MSL2021/23/24 LED drivers provide connectivity peripherals that allow wireless communication:

- The I<sup>2</sup>C serial port interfaces with Atmel AVR<sup>®</sup> micro-controllers, such as the tinyAVR<sup>®</sup> and megaAVR<sup>®</sup> low-cost, low-power devices
- The I<sup>2</sup>C serial port allows wireless communication via ZigBee Light Link and 6LoWPAN, as well as wired communication such as power line carrier, DALI and DMX

## Getting Started

For a head start on your lighting design, you can take advantage of the MSL202X Evaluation Kit that will include:

- An isolated AC/DC power supply that runs on universal input (90VAC to 240 VAC)
- An integrated LED load board with one white LED string and one red LED string
- An on-board AVR microcontroller to I<sup>2</sup>C to USB/parallel bridge for programming and controlling the LED driver

For more details about the MSL2021/23/24 family of LED drivers, visit: [http://www.atmel.com/Microsite/msl2021\\_msl2023\\_msl2024\\_led\\_drivers/default.aspx](http://www.atmel.com/Microsite/msl2021_msl2023_msl2024_led_drivers/default.aspx).

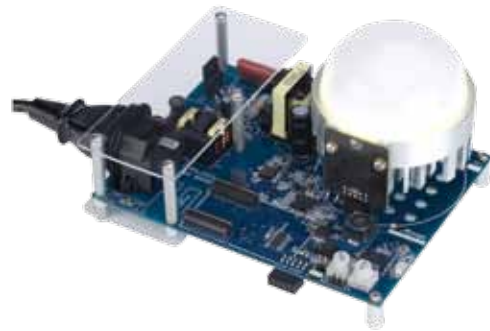

**Atmel Corporation** 1600 Technology Drive, San Jose, CA 95110 USA **T:** (+1)(408) 441.0311 **F:** (+1)(408) 436.4200 | **www.atmel.com**

© 2013 Atmel Corporation. All rights reserved. / Rev.: 45021A-MSL2021-LED-Driver\_E\_US\_022013

Atmel<sup>®</sup>, Atmel logo and combinations thereof, and others are registered trademarks or trademarks of Atmel Corporation or its subsidiaries. ARM<sup>®</sup>, ARMPowered<sup>®</sup> logo and others are the registered trademarks or trademarks of ARM Ltd. Other terms and product names may be the trademarks of others. Atmel logo and combinations thereof, and others are registered trademarks or trademarks of Atmel Corporation or its subsidiaries.

Disclaimer: The information in this document is provided in connection with Atmel products. No license, express or implied, by estoppel or otherwise, to any intellectual property right is granted by this document or in connection with the sale of Atmel products. EXCEPT AS SET FORTH IN THE ATMEL TERMS AND CONDITIONS OF SALES LOCATED ON THE ATMEL WEBSITE, ATMEL ASSUMES NO LIABILITY WHATSOEVER AND DISCLAIMS ANY EXPRESS, IMPLIED OR STATUTORY WARRANTY RELATING TO ITS PRODUCTS INCLUDING, BUT NOT LIMITED TO, THE IMPLIED WARRANTY OF MERCHANTABILITY, FITNESS FOR A PARTICULAR PURPOSE, OR NON-INFRINGEMENT. IN NO EVENT SHALL ATMEL BE LIABLE FOR ANY DIRECT, INDIRECT, CONSEQUENTIAL, PUNITIVE, SPECIAL OR INCIDENTAL DAMAGES (INCLUDING, WITHOUT LIMITATION, DAMAGES FOR LOSS AND PROFITS, BUSINESS INTERRUPTION, OR LOSS OF INFORMATION) ARISING OUT OF THE USE OR INABILITY TO USE THIS DOCUMENT, EVEN IF ATMEL HAS BEEN ADVISED OF THE POSSIBILITY OF SUCH DAMAGES. Atmel makes no representations or warranties with respect to the accuracy or completeness of the contents of this document and reserves the right to make changes to specifications and products descriptions at any time without notice. Atmel does not make any commitment to update the information contained herein. Unless specifically provided otherwise, Atmel products are not suitable for, and shall not be used in, automotive applications. Atmel products are not intended, authorized, or warranted for use as components in applications intended to support or sustain life.