

0.5 mm Pitch, 5.8 mm above the board, vertical connector for FPC

FH40 Series

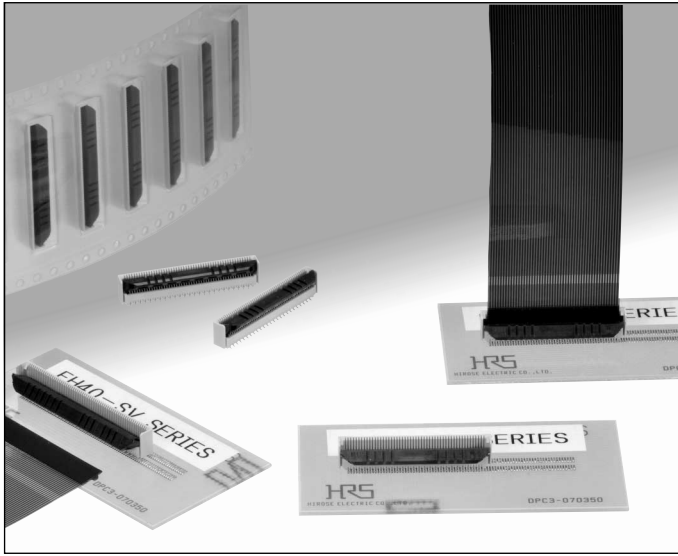

●Strong actuator construction

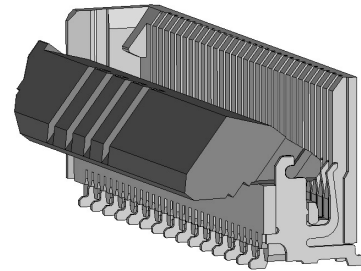

■Features

1. Reduction in connection man-hours (a 30% reduction compared to our conventional item)

Our unique actuator form enables the completion of both FPC insertion ~ joint in the same motion.

2. Prevention of half and diagonal joints

The side catcher for FPC positioning ensures accurate FPC insertion.

3. Durable structure and no lost actuator

The unique terminal form means the actuator is retained, even under rough operation conditions.

4. One-finger operation of the actuator

Proven (in several other Hirose's connectors!) Flip-Lock rotating actuator assures reliable mechanical and electrical connection with FPC, confirming it with a definite tactile feel.

5. Accepts standard FPC thickness

0.3mm thick standard Flexible Printed Circuit (FPC) can be used.

6. Board placement with automatic equipment

Flat upper surface and tape and reel packaging facilitate vacuum pick-up and placement.
Standard reel packaging contains 1,000 connectors.

7. Halogen-free *

*As defined by IEC61249-2-21
Br-900ppm maximum, Cl-900ppm maximum,
Cl + Br combined-1,500ppm maximum

●Simple FPC insertion

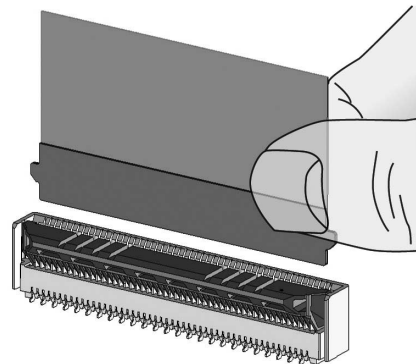

●Lock

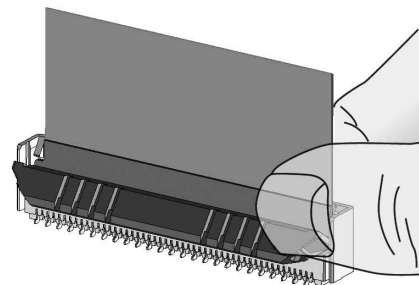

■ Specifications

Ratings	Current rating: 0.5A DC(Note 1)	Operating Temperature Range: -40 to +85°C (Note 2)	Storage Temperature Range: -10 to +50°C (Note 2)
	Voltage rating: 50 Vrms AC	Operating Humidity Range: Relative humidity 90% max. (No condensation)	Storage Humidity Range: Relative humidity 90% max. (No condensation)

Recommended FPC Thickness	0.3±0.05 mm, Gold plated contact pads
---------------------------	---------------------------------------

Item	Specification	Conditions
1. Insulation resistance	50 MΩ min.	100V DC
2. Withstanding voltage	No flashover or insulation breakdown	150 Vrms AC / one minute
3. Contact resistance	50 mΩ max. Including FPC and FFC conductor resistance	1 mA, AC max (AC: 1kHz)
4. Durability	Contact resistance: 50 mΩ max. No damage, cracks, or parts dislocation	20 cycles
5. Vibration	No electrical discontinuity of 1μs or longer Contact resistance: 50 mΩ max. No damage, cracks, or parts dislocation	Frequency: 10 to 55 Hz, single amplitude of 0.75 mm, 10 cycles in each of the 3 axis.
6. Shock	No electrical discontinuity of 1μs or longer Contact resistance: 50 mΩ max. No damage, cracks, or parts dislocation	Acceleration of 981 m/s ² , 6 ms duration, sine halfwave, 3 cycles in each of the 3 axis.
7. Humidity(Steady state)	Contact resistance: 50 mΩ max. Insulation resistance: 50 MΩ min. No damage, cracks, or parts dislocation	96 hours at 40°C and humidity of 90 to 95%
8. Temperature Cycle	Contact resistance: 50 mΩ max. Insulation resistance: 50 MΩ min. No damage, cracks, or parts dislocation	Temperature: -40°C → 15°C to 35°C → 85°C → 15°C to 35°C Time: 30 → 2 to 3 → 30 → 2 to 3(minutes) 5 cycles
9. Resistance to Soldering heat	No deformation of components affecting performance	Reflow: At the recommended temperature profile Manual soldering: 350°C±5°C for 5 seconds

Note 1: When passing the current through all of the contacts, use 70% of the rated current.

Note 2: Includes temperature rise caused by current flow.

Note 3: The term "storage" refers to products stored for a long period prior to mounting and use.

The operating temperature and humidity range covers the non-conducting condition of installed connectors in storage, shipment or during transportation after board mounting.

Note 4: Information contained in this catalog represents general requirements for this Series.

Contact us for the drawings and specifications for a specific part number shown.

■ Material

Part	Material	Finish	Remarks
Insulator	LCP	Color : Beige	UL94V-0
	LCP	Color : Black	
Contact	Phosphor bronze	Gold plated	—————

■ Ordering information

FH 40 - 50S - 0.5 SV

① ② ③ ④ ⑤

① Series Name	: FH
② Series No.	: 40
③ Number of positions	: 10 to 80
④ Contact pitch	: 0.5mm
⑤ SV	: SMT vertical mounting type

■ Connector Dimensions

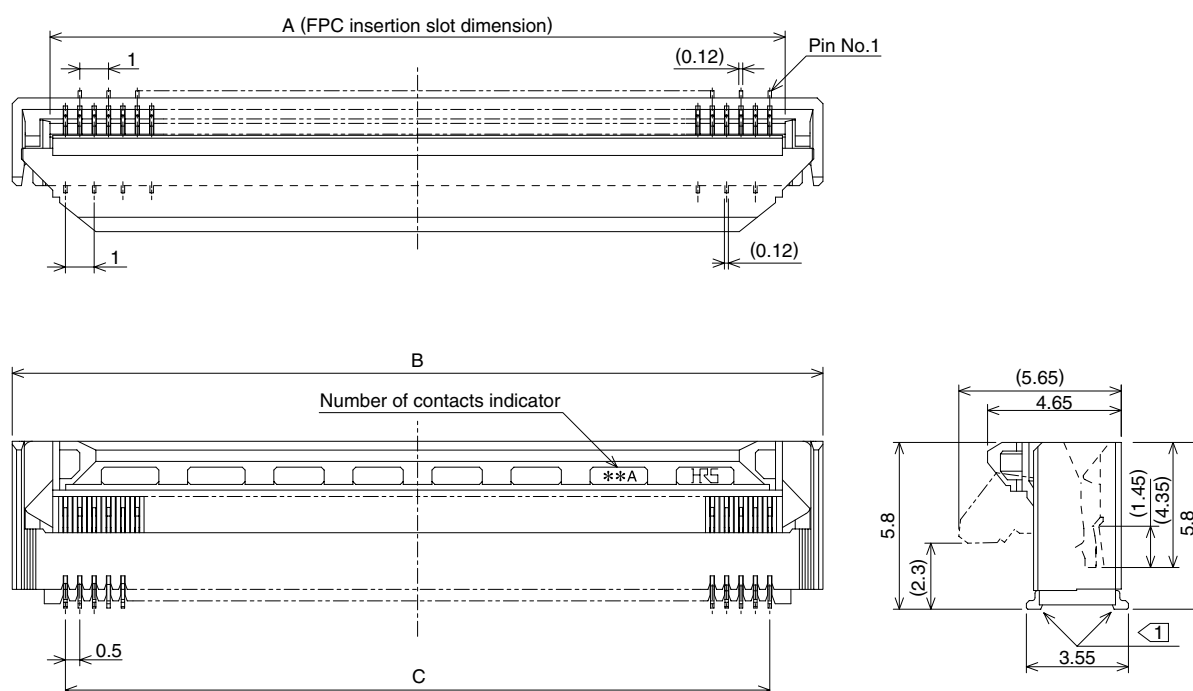

Note 1: The coplanarity of each terminal lead within specified dimension is 0.1 mm Max.

Note 2 : Packaged on tape and reel only. Check packaging specification.

Note 3 : Slight variations in color of the plastic compounds do not affect form, fit or function of the connector.

Note 4 : After reflow, the terminal plating may change color, however this does not represent a quality issue.

Unit:mm

Part Number	CL No.	Number of Contacts	A	B	C
FH40-10S-0.5SV	580-2104-6	10	5.57	8.2	4.5
FH40-20S-0.5SV	580-2105-9	20	10.57	13.2	9.5
FH40-24S-0.5SV	580-2106-1	24	12.57	15.2	11.5
FH40-30S-0.5SV	580-2108-7	30	15.57	18.2	14.5
FH40-40S-0.5SV	580-2107-4	40	20.57	23.2	19.5
FH40-45S-0.5SV	580-2101-8	45	23.07	25.7	22
FH40-50S-0.5SV	580-2100-5	50	25.57	28.2	24.5
FH40-60S-0.5SV	580-2109-0	60	30.57	33.2	29.5
FH40-64S-0.5SV	580-2102-0	64	32.57	35.2	31.5
FH40-80S-0.5SV	580-2103-3	80	40.57	43.2	39.5

Note 1 : Tape and reel packaging (1,000 pieces/reel).

Order by number of reels.

Recommended PCB mounting pattern and metal mask dimensions

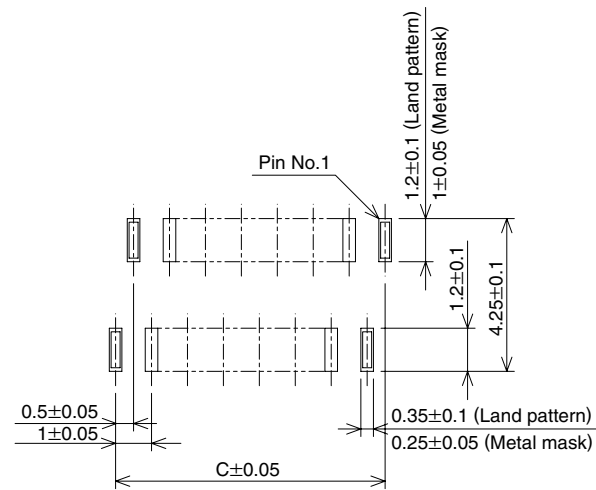

Recommended metal mask thickness : $t=0.15$

Recommended FPC Dimensions

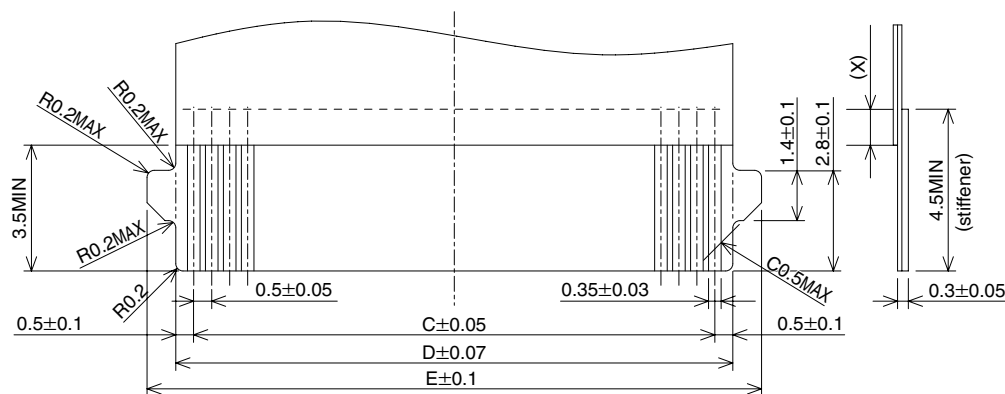

Note 1 : Stiffener dimension should be 3.5mm min., and X dimension should be 0.5mm for improved flexibility of FPC.

Unit:mm

Part Number	CL No.	Number of Contacts	C	D	E
FH40-10S-0.5SV	580-2104-6	10	4.5	5.5	7.1
FH40-20S-0.5SV	580-2105-9	20	9.5	10.5	12.1
FH40-24S-0.5SV	580-2106-1	24	11.5	12.5	14.1
FH40-30S-0.5SV	580-2108-7	30	14.5	15.5	17.1
FH40-40S-0.5SV	580-2107-4	40	19.5	20.5	22.1
FH40-45S-0.5SV	580-2101-8	45	22	23	24.6
FH40-50S-0.5SV	580-2100-5	50	24.5	25.5	27.1
FH40-60S-0.5SV	580-2109-0	60	29.5	30.5	32.1
FH40-64S-0.5SV	580-2102-0	64	31.5	32.5	34.1
FH40-80S-0.5SV	580-2103-3	80	39.5	40.5	42.1

■ Recommended FPC construction

1. Using Single-sided FPC

FPC : Flexible Printed Circuit

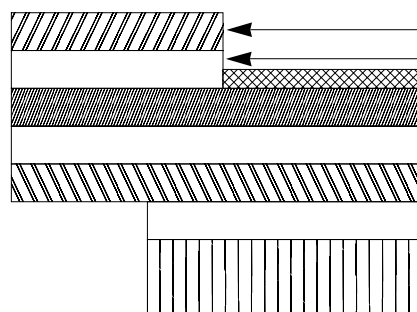

Material Name	Material	Material Thickness (μm)
Covering film layer	Polyimide 1 mil thick.	(25)
Cover adhesive		(25)
Surface treatment	0.2μm thick gold plated over 1 to 5μm nickel underplating	3
Copper foil	Cu 1oz	35
Base adhesive	Thermosetting adhesive	25
Base film	Polyimide 1 mil thick	25
Reinforcement material adhesive	Thermosetting adhesive	40
Stiffener	Polyimide 7 mil thick	175
Total		303

2. Using Double-sided FPC

FPC : Flexible Printed Circuit

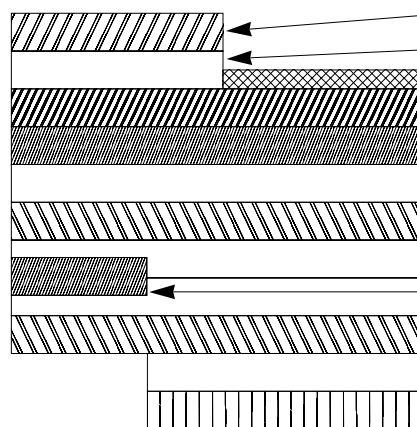

Material Name	Material	Material Thickness (μm)
Covering film layer	Polyimide 1 mil thick.	(25)
Cover adhesive		(25)
Surface treatment	0.2μm thick gold plated over 1 to 5μm nickel underplating	3
Through-hole copper	Cu	15
Copper foil	Cu 1/2oz	18
Base adhesive	Thermosetting adhesive	18
Base film	Polyimide 1 mil thick	25
Base adhesive	Thermosetting adhesive	18
Copper foil	Cu 1/2oz	(18)
Cover adhesive	Thermosetting adhesive	25
Covering film layer	Polyimide 1 mil thick.	25
Reinforcement material adhesive	Thermosetting adhesive	50
Stiffener	Polyimide 4 mil thick	100
Total		297

* To prevent release of the FPC due to its bending, use of the double sided FPC with copper foil on the back side is NOT RECOMMENDED.

3. Precautions

- 1: This specification is a recommendation for the construction of the FH40 Series FPC (t=0.3±0.05).
- 2: For details about the construction, please contact the FPC manufacturers.

■ Packaging Specification

● Embossed Carrier Tape Dimensions (Tape width to 24mm max.)

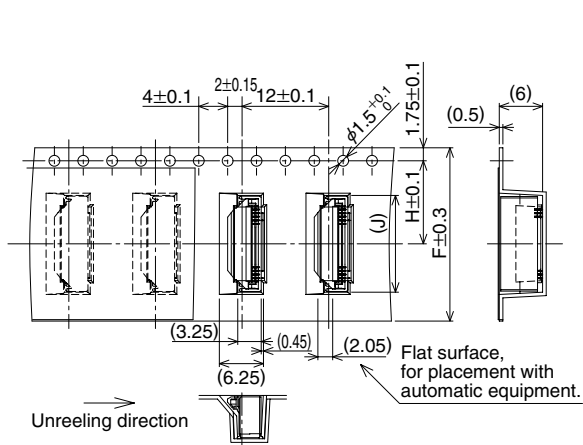

● Embossed Carrier Tape Dimensions (Tape width 32mm min.)

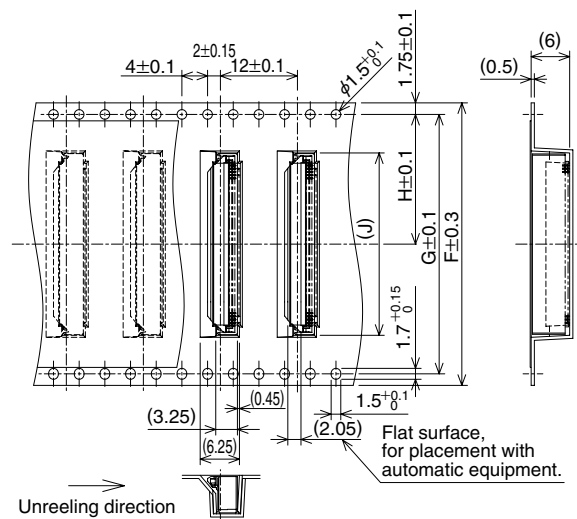

● Reel Dimensions

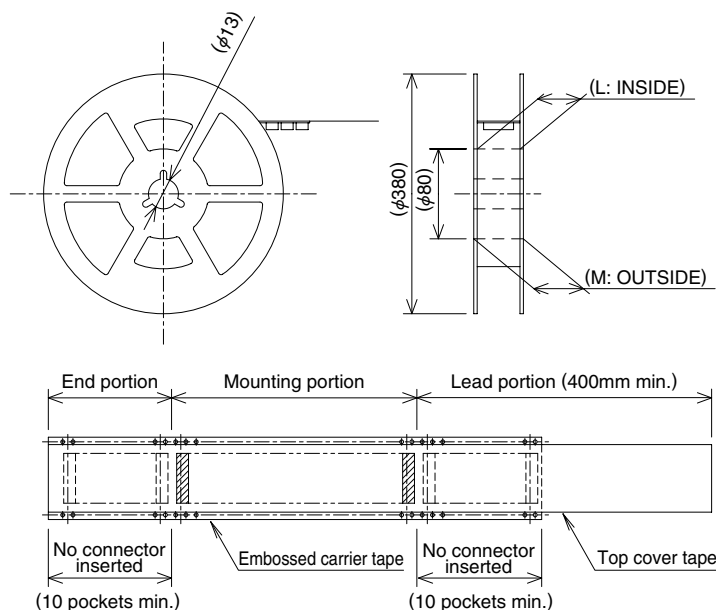

Unit:mm

Part Number	CL No.	Number of Contacts	F	G	H	J	K	L
FH40-10S-0.5SV	580-2104-6	10	16	—	7.5	8.4	17.4	21.4
FH40-20S-0.5SV	580-2105-9	20	24	—	11.5	13.4	25.4	29.4
FH40-24S-0.5SV	580-2106-1	24	24	—	11.5	15.4	25.4	29.4
FH40-30S-0.5SV	580-2108-7	30	32	28.4	14.2	18.4	33.4	37.4
FH40-40S-0.5SV	580-2107-4	40	44	40.4	20.2	23.4	45.4	49.4
FH40-45S-0.5SV	580-2101-8	45	44	40.4	20.2	25.9	45.4	49.4
FH40-50S-0.5SV	580-2100-5	50	44	40.4	20.2	28.4	45.4	49.4
FH40-60S-0.5SV	580-2109-0	60	56	52.4	26.2	33.4	57.4	61.4
FH40-64S-0.5SV	580-2102-0	64	56	52.4	26.2	35.4	57.4	61.4
FH40-80S-0.5SV	580-2103-3	80	56	52.4	26.2	43.4	57.4	61.4

Note 1 : Tape and reel packaging (1,000 pieces/reel).

■ Temperature Profile

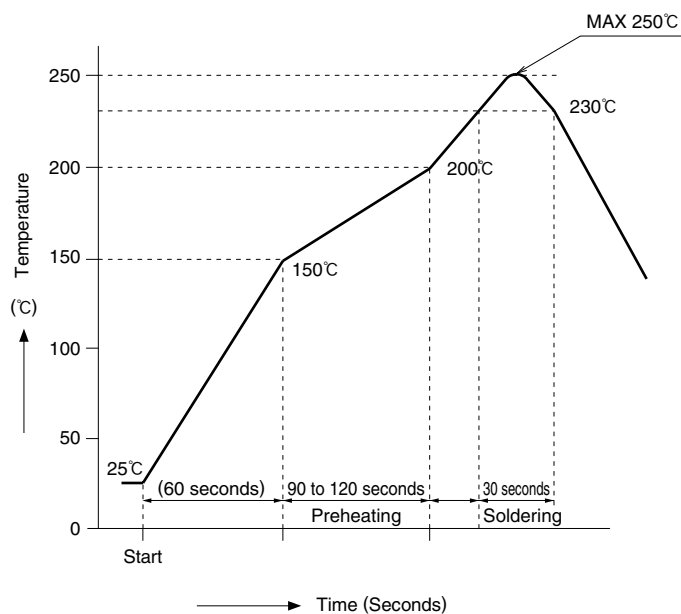

HRS test conditions

Solder method	:Reflow, IR/hot air
Environment:	:Room air
Solder composition	:Paste, 96.5%Sn/3%Ag/0.5%Cu (Senju Metal Industry, Co., Ltd.'s Part Number: M705-GRN360-K2-V)
Test board	:Glass epoxy 30mm×66mm×0.8mm thick
Land dimensions	:0.35mm×1.2mm
Metal mask	:0.25×1.0×0.15mm thick

The temperature profiles shown are based on the above conditions.

In individual applications the actual temperature may vary, depending on solder paste type, volume / thickness and board size / thickness. Consult your solder paste and equipment manufacturer for specific recommendations.

■ Operation and Precautions

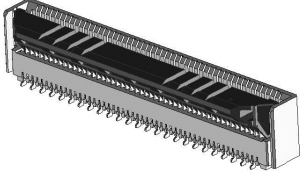
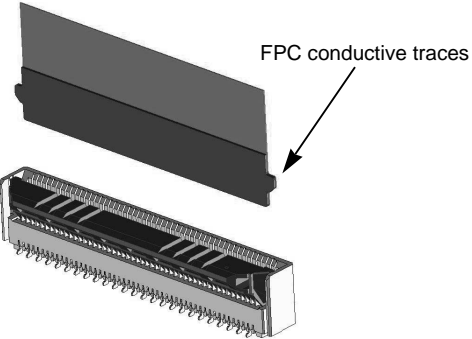
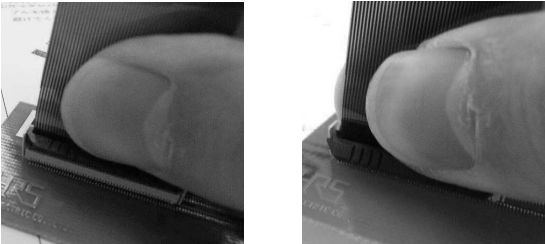
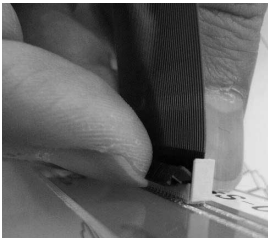
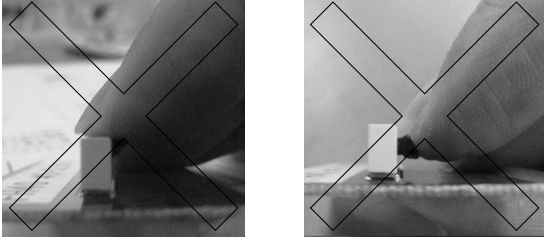
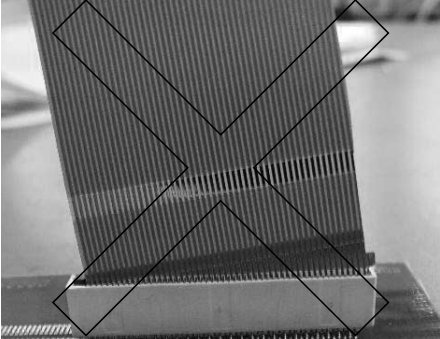
Operation	Precautions
<p>1. FPC Termination procedure.</p> <p>① Verify that the actuator is positioned upright. If the actuator has rotated to the side, carefully rotate it upright.</p>  <p>② Insert the FPC vertically in the connector slot assuring that the conductive traces of the FPC are facing away from the actuator.</p>  <p>③ Press down the actuator in the direction shown.</p>  <p>2. FPC Removal</p> <p>① Rotate the actuator upward and withdraw the FPC.</p> 	<p>① Avoid forcing the actuator up or down without the FPC inserted.</p>  <p>② Application of excessive force to the inserted FPC may cause damage to connector and may affect the reliability of electrical connection.</p>  <p>Do not insert the FPC diagonally. Doing so will result in the corners of the FPC catching on the contacts and will cause deformation of the contacts.</p>



HIROSE ELECTRIC CO.,LTD.

5-23,OSAKI 5-CHOME,SHINAGAWA-KU,TOKYO 141-8587,JAPAN
PHONE: 81-3-3491-5300, FAX: 81-3-3495-5230
<http://www.hirose.com>
<http://www.hirose-connectors.com>