

Long Stroke Actuator with Operating Position Marks

- Long stroke (7 mm) in a small package.
- Easy assembly with panel mount design.
- Quick-connection terminals facilitate wiring.
- Simple leaf switch structure.

RoHS Compliant



Ordering Information

Model Number Legend

D3DC-□
1

1. Contact Form
- 1: SPST-NC
 - 2: SPST-NO

List of Models

Contact form	Model
SPST-NC	D3DC-2
SPST-NO	D3DC-3

Specifications

Ratings

Rated voltage	Resistive load
30 VDC	0.1 A

Note: The electrical rating applies under the following test conditions:
 Ambient Temperature = 20±2°C
 Ambient Humidity = 65±5%,
 Operating frequency = 20 operations/min.

Characteristics

Operating speed	0.5 mm to 1 mm/s
Operating frequency	Mechanical: 30 operations/min max. Electrical: 20 operations/min max.
Insulation resistance	100 MΩ min. (at 500 VDC)
Contact resistance	300 mΩ max.
Dielectric strength	600 VAC, 50/60 Hz for 1 min between terminals of the same polarity 1,500 VAC, 50/60 Hz for 1 min between current-carrying metal parts and ground
Vibration resistance (see note 2)	Malfunction: 10 to 55 Hz, 1.5-mm double amplitude
Shock resistance (see note 2)	Destruction: 500 m/s ² max. Malfunction: 100 m/s ² max.
Degree of protection	IEC IP00
Proof tracking index (PTI)	600
Ambient operating temperature	-25°C to 85°C (at 60% RH max.) (with no icing or condensation)
Ambient operating humidity	85% max. (for 5°C to 35°C)
Life expectancy	Mechanical : 100,000 operations min. (30 operations/min) Electrical : 100,000 operations min. (20 operations/min)
Weight	Approx. 2 g

- Note:**
- The data given above are initial values.
 - The contacts do not open or close for more than 1 ms.

■ Approved Standards

UL Recognized
CSA Certified (UL approval)

Rerated voltage	Rated Load
30 VDC	0.1 A

■ Contact Specifications

Item	Specification
Specification	Rivet
Material	Silver
Gap (standard value)	0.3 mm
Minimum applicable load (see note)	1 mA at 5 VDC

Note: Minimum applicable loads are indicated by N standard reference values. This value represents the failure rate at a 60% (λ_{60}) reliability level (JIS C5003).
The equation $\lambda_{60}=0.5 \times 10^{-6/l}$ operations indicates that a failure rate of 1/2,000,000 operations can be expected at a reliability level of 60%.

■ Contact Form

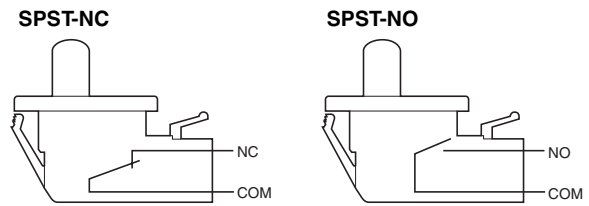

Dimensions

■ Dimensions and Operating Characteristics

Note: 1. Unless otherwise specified, all units are in millimeters and a tolerance of ± 0.4 mm applies to all dimensions.
2. The operating characteristics are for operation in direction A (indicated by the arrow).

D3DC-2
D3DC-3

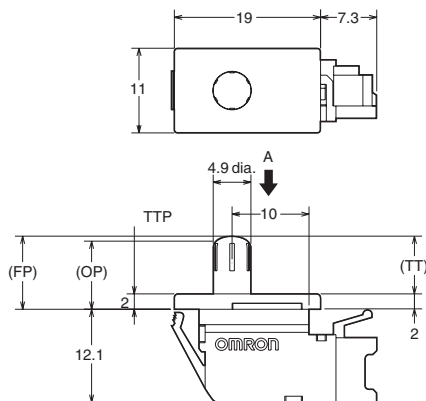

Model	D3DC-2	D3DC-3
OF max.	1.0 N {102 gf}	
TT	7.0 mm (reference value)	
FP	9.5 mm (reference value)	
OP min.	6.7 mm	
TTP	2.0 mm (reference value)	

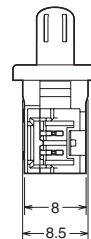

■ Mounting Panel Cutout Dimensions

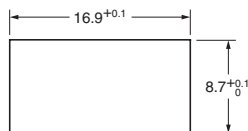

Note: Mounting plate thickness: 0.75 mm to 1.50 mm.
All units are in millimeters unless otherwise indicated.

■ Connectors

The terminals connect to JST's XA Connector.

The XA Connector consists of the following components.

Contact: SXA-001T-P0.6

Housing: XAP-02V-1

OMRON does not sell the HL Connector. Contact the following.

J.S.T. Manufacturing Co., Ltd. (Japan)
Phone: +81-6-6968-1121
Fax: +81-6-6964-2666

J.S.T. (U.K.) Ltd. (United Kingdom)
Phone: +44-1986-874131
Fax: +44-1986-874276

J.S.T. Corporation (U.S.A.)
Phone: +1-847-473-1957
Fax: +1-847-473-0144

J.S.T. (H.K.) Co. Ltd. (Hong Kong)
Phone: +852-24137979
Fax: +852-24111193

Precautions

Refer to *General Information*.

Be sure to read the precautions and information common to all Snap Action and Detection Switches, contained in the Technical User's Guide, "Snap Action Switches, Technical Information" for correct use.

■ Correct Use

Mounting

This product does not have a waterproof or drip-proof construction. Ensure that water does not enter the switch interior. In particular, do not use the switch in locations where water may be spilled or flow over the switch. Doing so may result in deterioration of the insulation.

Wiring

Do not use the switch with a large force applied to the connector or lead wire. Doing so may result in rattling or contact failure.

Storage Environment

Storing the switch in a plastic bag will help prevent discoloration due to sulfuration of the (silver-plated) terminals.

Do not use the switch in locations subject to harmful gases or to high temperatures or humidity levels. Depending on the location, it is recommended that Switches are inspected between 3 and 6 months after the date of manufacturer.

Using Micro Loads

Using a model for ordinary loads to switch microloads may result in faulty operation. Instead, use the models that are designed for microloads and that operate in the following range.

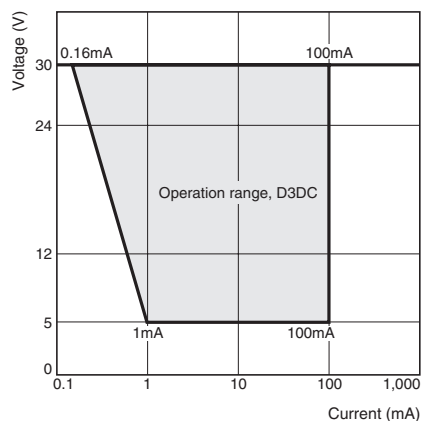

However, even when using microload models within the operating range shown above, if inrush current or inductive voltage spikes occur when the contact is opened or closed, then contact wear may increase and decrease the service life. Therefore, insert a contact protection circuit where necessary.

■ Cautions

Handling

Do not expose the switch to shocks, such as by dropping it. Doing so may damage or deform the switch.

Do not apply lubrication to the sliding parts, such as pushbuttons or actuators. Doing so may result in faulty operation or contact failure.

In order to ensure stable contact force for contacts, actuate beyond the recommended operating point and release to free position.

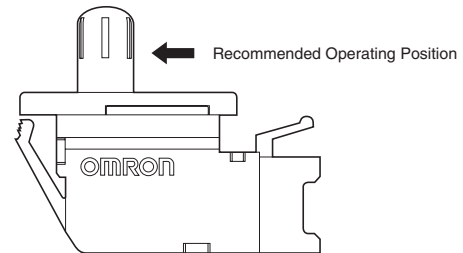

ALL DIMENSIONS SHOWN ARE IN MILLIMETERS.

To convert millimeters into inches, multiply by 0.03937. To convert grams into ounces, multiply by 0.03527.