



1x1 802.11abgn + BT4.0 + ZigBee

M2MCombo™ RS9113 is Redpine Signals' ultra-low-power, single spatial stream, dual-band 802.11n + BT4.0 + Zigbee Convergence SoC. The RS9113 chipset provides low-cost CMOS integration of a multi-threaded MAC processor, baseband digital signal processing, analog front-end, crystal oscillator, calibration OTP, dual-band RF transceiver and dual-band high-power amplifiers, thus providing a cost-effective solution targeting low-power and high QoS wireless applications.

M2MCombo™ leverages and improves upon Redpine's proven low power innovations from Lite-Fi™ products and provides BT4.0 and ZigBee convergence solution for integration into mobile and M2M communication devices. With its embedded four-threaded processor and on-chip ROM and RAM, this chipset enables integration into zero host load applications with capability to run Wi-Fi security supplicant and TCP/IP on-chip thus setting a new benchmark for the "internet-of-things" market. With advanced ultra-low-power PMU, integrated analog peripherals and support for a variety of digital peripherals – RS9113 enables very low-cost implementations for wireless embedded and M2M applications.

Features and Benefits

- Ultra-low-power, low-cost and high-throughput 1 Tx – 1 Rx Dual-band 802.11n + BT4.0 (Bluetooth LE dual-mode) + ZigBee (802.15.4-2006)
- Data rates up to 150 Mbps using 1-Spatial Stream 802.11n MCS-7, 40MHz bandwidth mode for high user throughput
- Hardware Assisted Radar-detection for compliance to FCC and ETSI norms, enabling usage of more channels in the 5GHz band
- High performance Bluetooth receiver with -95dBm Rx sensitivity
- Support for Bluetooth Transmit power class-1 with integrated PA
- High performance ZigBee receiver with -101dBm Rx sensitivity
- Support for multiple ZigBee output powers up to +20dBm with integrated PA
- Innovative coexistence algorithms for optimum throughput of Wi-Fi and collocated Bluetooth and ZigBee modems
- Integrated Ultra-low-power subsystem with <2uA watch-dog mode and <30uA standby mode.
- Integrated Ultra-low-power subsystem with <2uA watch-dog mode and <30uA standby mode.
- Integrated ThreadArch® Four-threaded processor with on chip memory for achieving high-throughputs with low-host overhead and customer specific differentiations
- On-chip processing and memory enables option to offload Wi-Fi security supplicant and TCP/IP stack enabling zero-host load and extreme ease of integration for the "internet-of-things"
- Advanced power management techniques adaptively minimize system power in various application profiles.
- High level of CMOS integration to minimize RBOM (E.g., On-chip OTP, Crystal Oscillator and High Power Amplifiers)
- Rich set of built-in analog and digital peripherals for enabling low-host load and zero-host applications
- Support for multiple host interfaces to allow maximum flexibility for the system integrator. Host interfaces supported are USB 2.0, SDIO, SPI and UART

Specifications

Network Standard Support	IEEE 802.11a/b/g/j, 802.11n, 802.11d/e/i/w, 802.1X, 802.11k/r/v, 802.11h Bluetooth v2.1 + EDR, v3.0 + HS, v4.0 802.15.4-2006 (2.4GHz)
Data Rates	802.11n: from 6.5 Mbps to 150 Mbps (MCS 0-7) 802.11a/g: from 6 Mbps to 54 Mbps 802.11b: from 1 Mbps to 11 Mbps Bluetooth: 1, 2, 3Mbps 802.15.4-2006: 250Kbps
Modulation Techniques	OFDM with BPSK, QPSK, 16-QAM, 64-QAM and 256-QAM 802.11b with CCK and DSSS Bluetooth: GFSK, DQPSK, 8DPSK 802.15.4-2006: DSSS
QoS	WMM and WMM Power Save Support
802.11n Advanced Features	1-SS, 40MHz bandwidth, Greenfield Preamble, Short-GI, 1 spatial stream STBC, RIFS, Aggregation with Block-ack, PSMP, MTBA, Fragmentation and Virtual AP support (up to 8 BSSIDs)
Host Interfaces	SDIO, USB 2.0, SPI, UART
Other Peripherals/ Interfaces	I2C, I2S, SPI, QSPI, UART, GPIO, JTAG, Analog and Ultra-low-power peripherals
Supply Voltage	3.0-3.6V, 1.8-3.6V
Operating Temperature	Industrial Grade -40°C to +85°C
Software and Regulatory Certification Support	WiFi Alliance (802.11abgn, WPA, WPA2 Personal and Enterprise, WMM, WMM-PS, WPS, Wi-Fi Direct™, Voice-Personal, Protected management frames), Cisco CCX v5, Zigbee Certification Bluetooth Qualification FIPS 140-2 World-Wide Regulatory Compliance (FCC, IC, CE, ETSI, TELEC)

Applications

- Smart-phones, Tablets and eReaders
- Cameras and Camcorders
- VoWi-Fi phones
- Gaming Consoles
- Wireless Sensor and RTLS Tags
- Smart Meters and In-home-devices (Displays/Thermostats)
- Medical Devices
- Other M2M applications

Module Reference Design

Redpine offers form-factor USB2.0 and SDIO reference designs along with software for manufacture testing and diagnostics. For details on availability please contact sales

Software Package

The RS9113 solution is accompanied by Redpine's OneBox™ embedded software framework. OneBox™ supports common API based Station, Access-point, Wi-Fi Direct™, dual-mode BT4.0, ZigBee-PRO and SEP2.0 functionality on a variety of host platforms and embedded operating systems. The software package includes complete firmware, reference drivers, application profiles and configuration graphical user interface (GUI) for Linux, Windows and Android operating systems.

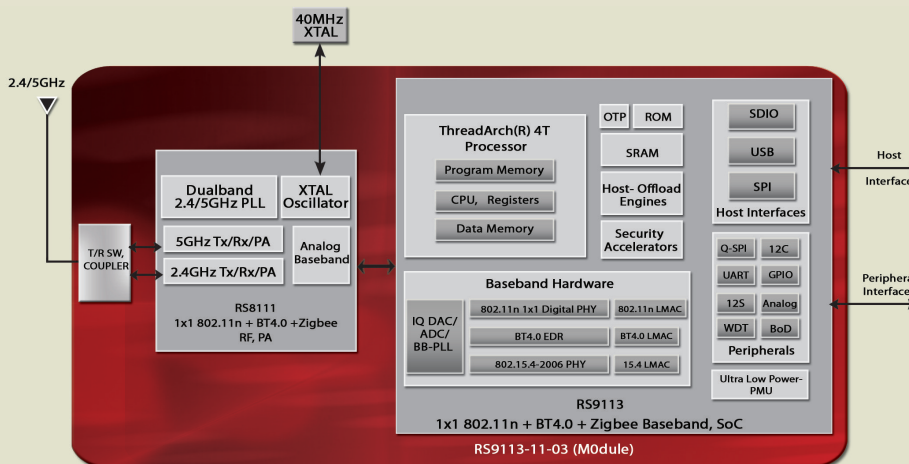

M2MCombo™ RS9113 System Diagram

For additional information, please contact Sales at Redpine Signals, Inc.:

Redpine Signals, Inc. • 2107 North First Street • Suite 680 • San Jose, CA 95131

Phone: +1 408 748 3385 • Email: sales@redpinesignals.com

www.redpinesignals.com

Redpine Signals, Inc. reserves the right to make changes to the product(s) or information contained herein without notice. No Liability is assumed as a result of their use or application. Redpine, Redpine Signals, the Redpine logo, Driving Wireless Convergence, WiSeConnect and Lite-Fi are trademarks of Redpine Signals, Inc. All other company names, products and logos are registered trademarks of their respective companies.

© Copyright 2012 Redpine Signals, Inc. All Rights Reserved.

REDPINE SIGNALS[®]
DRIVING WIRELESS CONVERGENCE[®]