

**Midcom**

LANDatacom

## Who is Wurth Electronics Midcom?

Wurth Electronics Midcom is a world leader in the production of standard and custom magnetics for communication and low power applications. Our products are used in a variety of electronic equipment ranging from personal computers and modems to telephone switching equipment, to credit card swiping machines, to high tech medical equipment and industrial controls. Wurth Electronics Midcom ships analog modem, digital telecom, switchmode power, and LAN magnetic products throughout North America and Internationally.

Several factors contribute to our tremendous success. Innovative designs, outstanding quality, and exceptional performance lead Midcom to every corner of the globe. The customer's complete satisfaction is the goal of our organization. It is achieved by our team working closely with our customer's team. High ethical standards and fairness are an integral part of our total effort. Our pride in workmanship, ingenuity in design, and strong work ethic help accomplish our aggressive goals.

## LAN Datacom Mission Statement

The LAN Business Unit will provide high volume, low cost magnetic components to the data communications industry. We will utilize our expertise in design for cost effective, yet highly reliable solutions to exceed the requirements of our customers.

## Contact Information

Wurth Electronics Midcom, Inc. USA  
 121 Airport Drive ~ PO Box 1330  
 Watertown, SD 57201  
 T: 605.886.4385 ~ F: 605.886.4486  
[www.we-online.com](http://www.we-online.com)  
[sales@midcom-inc.com](mailto:sales@midcom-inc.com)

Wurth Electronics Midcom, Inc. China  
 10/F Spectrum Tower ~ 53 Hung to Road  
 Kwun Tong, Kowloon, HK  
 T: 852.2320.4221 ~ F: 852.2352.3272  
[www.we-online.com](http://www.we-online.com)  
[asiasales@midcom-inc.com](mailto:asiasales@midcom-inc.com)

## Table of Contents

### RJ45 PoE (IEEE 802.3af) - Integrated Connectors

Single Port 10/100 Base-T PoE _____	4-5
Single Port 10/100 Base-T PoE Vertical _____	6
Single Port 10/100 Base-T PoE with Diodes _____	7-8
Single Port 10/100 Base-T PoE with Diodes Vertical _____	9

### RJ45 - Integrated Connectors

Single Port 10 Base-T TH _____	10
Single Port 10/100 Base-T TH 24 _____	11-15
Single Port 10/100 Base-T TH 24 Vertical _____	16-17
Single Port 10/100 Base-T TH 24 Unshielded _____	18-19
Single Port 10/100 Base-T TH 24 with Protection _____	20
Single Port 10/100 Base-T SMD 24 _____	21-22
Single Port 10/100 Base-T TH 25 _____	23-27
Single Port 10/100 Base-T TH 26 _____	28
Single Port 10/100 Base-T SMD 24 Low - Profile _____	29
Single Port 10/100 Base-T SMD 25 _____	30
Single Port 10/100 Base-T SMD 26 _____	31
Single Port 10/100 Base-T USB Combo _____	32-33
Single Port Gigabit TH _____	34-39
Single Port Gigabit TH Vertical _____	40-41
Single Port Gigabit SMD _____	42
Single Port Gigabit USB Combo _____	43-44
Multi Port 1x2 10/100 Base-T _____	45-46
Multi Port 1x4 10/100 Base-T _____	47-48
Multi Port 1x4 Gigabit _____	49-50
Multi Port 2x6 Gigabit _____	51-52
Multi Port 2x8 Gigabit _____	53-54
Multi Port 1x5 10/100 Base -T _____	55-56
Multi Port 2x1 10/100 Base-T _____	57
Multi Port 2x4 10/100 Base-T _____	58-59
Multi Port 2x6 10/100 Base-T _____	60-61

### Discrete PoE (IEEE 802.3af)

Single Port 10/100 Base-T PoE EDSO-G16 _____	62
Dual Port 10/100 Base-T PoE EDSO-G24 _____	63-64
Quad Port 10/100 Base-T PoE PDFP-G48 _____	65-66
Single Port Gigabit PoE PDFP-G24 _____	67-68
Dual Port Gigabit PoE PDFP-G48 _____	69-70

## Table of Contents continued

<b>Discrete PoE+</b>	
Single Port Gigabit PoE+ 24 pin _____	71
<b>Discrete</b>	
Single Port 10 Base-T PDSO-G16 _____	72
Single Port 10 Base-T PDFP-G16 _____	73
Quad Port 10 Base-T PDFP-G40 _____	74-75
Single Port 10/100 Base-T PCMCIA _____	76
Single Port 10/100 Base-T EDSO-G16 _____	77-78
Single Port 10/100 Base-T PDSO-G16 _____	79
Single Port 10/100 Base-T PDFP-G16 _____	80-81
Dual Port 10/100 Base-T PDFP-G24 _____	82
Dual Port 10/100 Base-T PDFP-G40 _____	83
Quad Port 10/100 Base-T PDFP-G40 _____	84-85
Half Port Gigabit PCMCIA _____	86
Single Port 10/100 Medical High Voltage _____	87
Single Port Gigabit Low Profile _____	88
Single Port Gigabit EDSO-G24 _____	89
Single Port Gigabit PDFP-G24 _____	90
Dual Port Gigabit PDFP-G48 _____	91-92
HPLN PDFP-G16 _____	93
AUI Transformers PDSO-G16 _____	94
Fiber to Coax Transformers EDSO-G16 _____	95
<b>IC Cross References</b> _____	96-100
<b>Glossary of Terms</b> _____	101-104
<b>Package Styles</b> _____	105-113
<b>Suggested Reflow Soldering Profile</b> _____	114
<b>LAN Transformer Design Inquiry</b> _____	115

**Electrical Characteristics**

Inductance	350uH Min.	0.1Vrms, 100kHz, 8mADC
Dielectric Rating	1500VAC	for 1 minute
Turns Ratio	1CT:1	±2%
Insertion Loss	-1.0dB max.	1MHz-100MHz
Return Loss	-18dB min.	1MHz-30MHz
	-16dB min.	30MHz-45MHz
	-14dB min.	45MHz-60MHz
	-12dB min.	60MHz-80MHz
Cross Talk	-35dB min.	1MHz-100MHz
Common Mode Rejection	-35dB min.	1MHz-100MHz

Note1: Electrical Characteristics for individual part may vary; see specification sheet for actual values.

**Features**

- Through hole
- AutoMDIX compatible
- PoE compatible (designed for 350mADC and 802.3af)
- Operating Temperature 0°C to 70°C
- Optional pin-outs and LEDs
- Industry standard connector footprint
- Optimum performance
- Cost Effective
- RoHS compliant

Part Number	LED (left-right)	Tab Direction	EMI Tabs
MIC64013-5180	Green-Yellow	Down	Yes

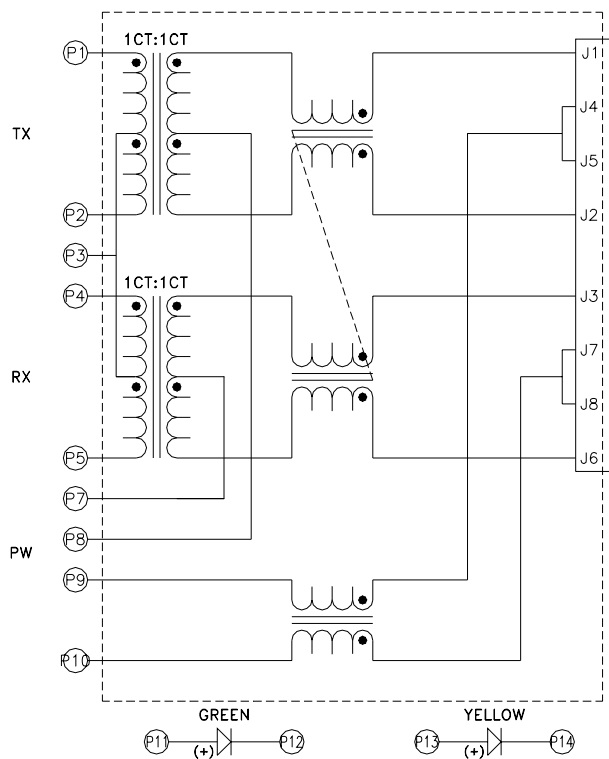

### Mechanical—M1

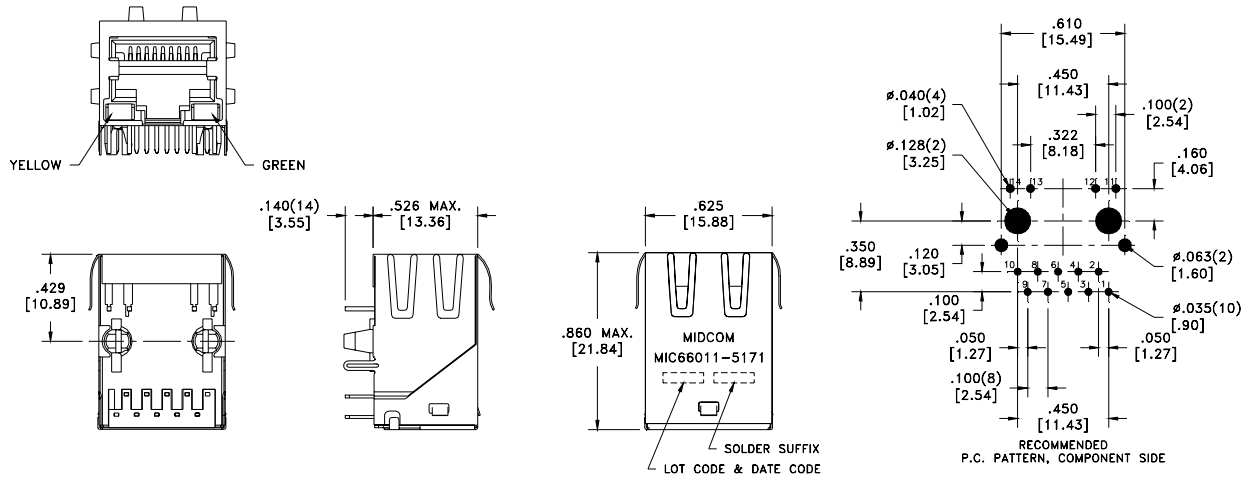

5/01/08 Details subject to change. Contact your Midcom sales representative for additional information. Dimensions: in/mm. All tolerances are  $\pm .010/0,25$  and electrical specifications are @ 25°C unless otherwise specified.

**Electrical Characteristics**

Inductance	350uH Min.	0.1Vrms, 100kHz, 8mADC
Choke Inductance	36uH Min.	0.1Vrms, 10kHz
Dielectric Rating	1500VAC	for 1 minute
Turns Ratio	1CT:1	±2%
Insertion Loss	-1.0dB max.	1MHz-100MHz
Return Loss	-18dB min.	1MHz-30MHz
	-16dB min.	30MHz-45MHz
	-14dB min.	45MHz-60MHz
	-12dB min.	60MHz-80MHz
Cross Talk	-30dB min.	1MHz-100MHz
Common Mode Rejection	-30dB typ.	1MHz-100MHz

**Features**

- Through hole
- PoE compatible (designed for 350mADC and 802.3af)
- Operating Temperature 0°C to +70°C
- Optional pin-outs and LEDs
- Industry standard connector footprint
- Optimum performance
- Cost Effective
- Both RoHS compliant and lead-terminal parts available

Note 1: Electrical Characteristics for individual part may vary; see specification sheet for actual values.

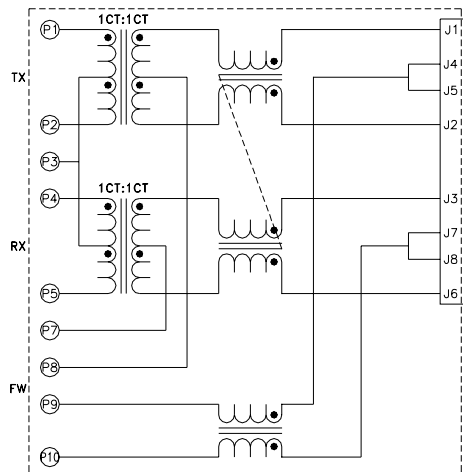

Part Number	LED (left-right)	Tab Direction	EMI Tabs
7499210210	Yellow-Green	Down	No

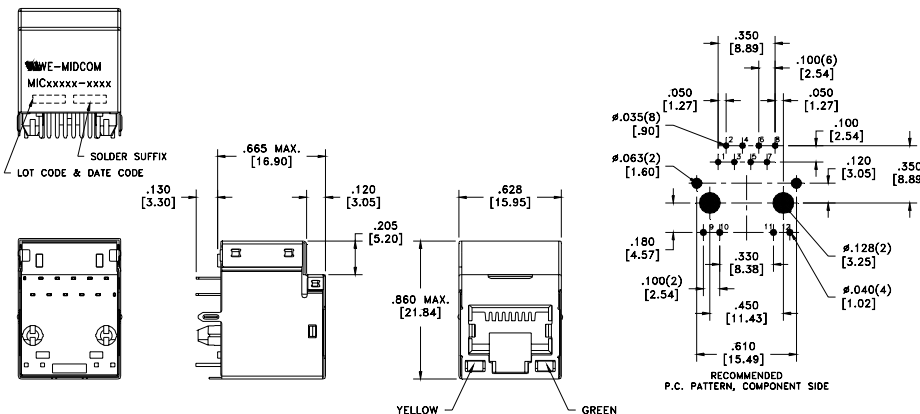

Details subject to change. Contact your Midcom sales representative for additional information. Dimensions: in/mm. All tolerances are ± .010/0.25 and electrical specifications are @ 25°C unless otherwise specified.

5/01/08

Integrated PoE with Diodes  
10/100 Base-T RJ45



LANDatacom

**Electrical Characteristics**

Inductance	350uH Min.	0.1Vrms, 100kHz, 8mADC
Dielectric Rating	1500VAC	for 1 minute
Turns Ratio	1CT:1	±2%
Insertion Loss	-1.0dB max.	1MHz-100MHz
Return Loss	-18dB min.	1MHz-30MHz
	-16dB min.	30MHz-45MHz
	-14dB min.	45MHz-60MHz
	-12dB min.	60MHz-80MHz
Cross Talk	-35dB min.	1MHz-100MHz
Common Mode Rejection	-35dB min.	1MHz-100MHz

Note1: Electrical Characteristics for individual part may vary; see specification sheet for actual values.

**Features**

- Through hole
- AutoMDIX compatible
- PoE compatible (designed for 350mADC and 802.3af)
- Operating Temperature -40°C to +85°C
- Optional pin-outs and LEDs
- Industry standard connector footprint
- Optimum performance
- Cost Effective
- Both RoHS compliant and lead-terminal parts available

Part Number	LED (left-right)	Tab Direction	EMI Tabs	Mechanical
MIC66210-5171	None	Down	No	M1
MIC66211-5171	Yellow-Green	Down	No	M1
MIC66011-5171	Yellow-Green	Down	Yes	M2
MIC66311-0171	Yellow-Green	Up	No	M3

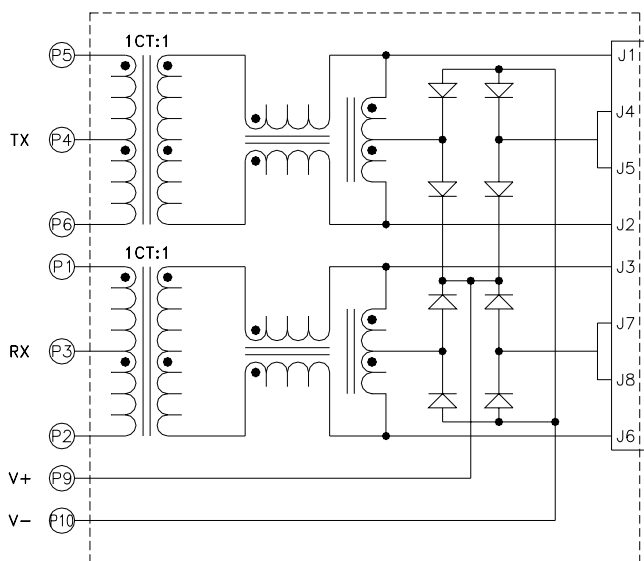

**Schematic 1**

LANDatacom

Mechanical—M1

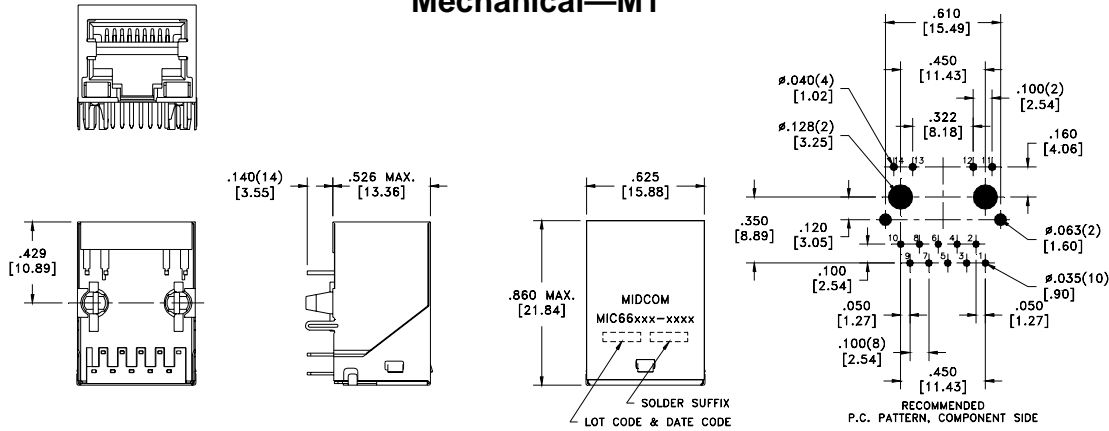

Mechanical—M2

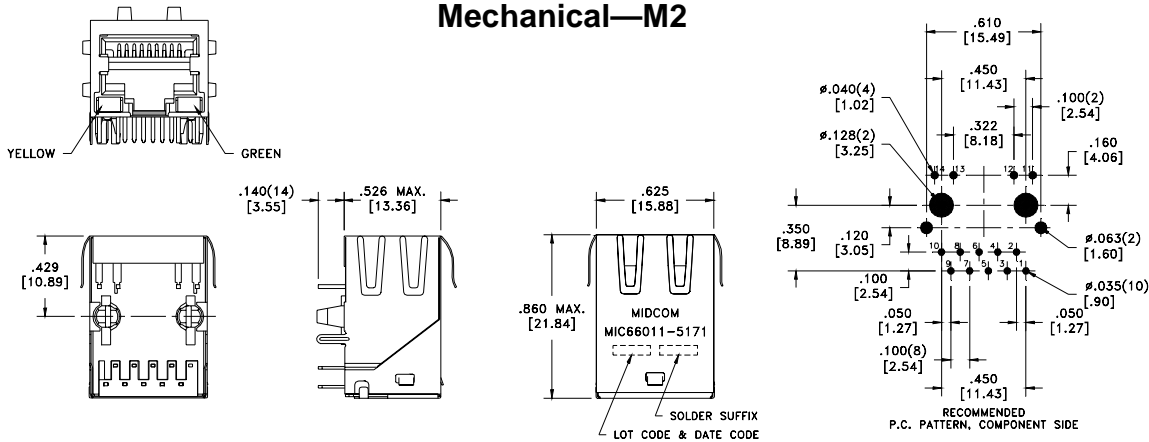

Mechanical—M3

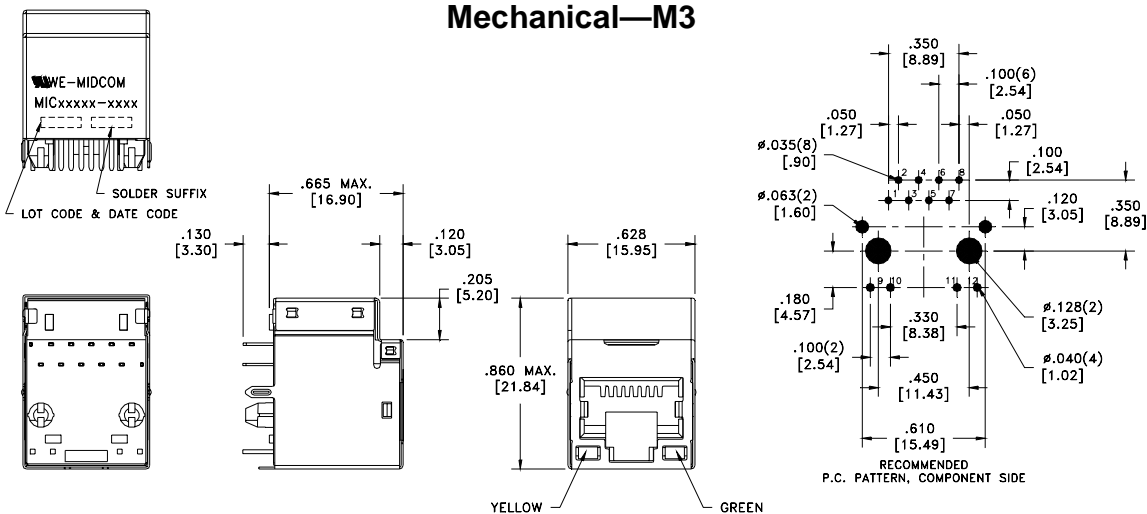

Details subject to change. Contact your Midcom sales representative for additional information. Dimensions: in/mm. All tolerances are  $\pm .010/0,25$  and electrical specifications are @ 25°C unless otherwise specified.



Integrated PoE with Diodes  
10/100 Base-T Vertical RJ45



LANDatacom

**Electrical Characteristics**

Inductance	350uH Min.	0.1Vrms, 100kHz, 8mADC
Dielectric Rating	1500VAC	for 1 minute
Turns Ratio	1CT:1	±2%
Insertion Loss	-1.0dB max.	1MHz-100MHz
Return Loss	-18dB min.	1MHz-30MHz
	-16dB min.	30MHz-45MHz
	-14dB min.	45MHz-60MHz
	-12dB min.	60MHz-80MHz
Cross Talk	-35dB min.	1MHz-100MHz
Common Mode Rejection	-35dB min.	1MHz-100MHz

Note1: Electrical Characteristics for individual part may vary; see specification sheet for actual values.

**Features**

- Through hole
- AutoMDIX compatible
- PoE compatible (designed for 350mADC and 802.3af)
- Operating Temperature -40°C to +85°C
- Optional pin-outs and LEDs
- Industry standard connector footprint
- Optimum performance
- Cost Effective
- Both RoHS compliant and lead-terminal parts available

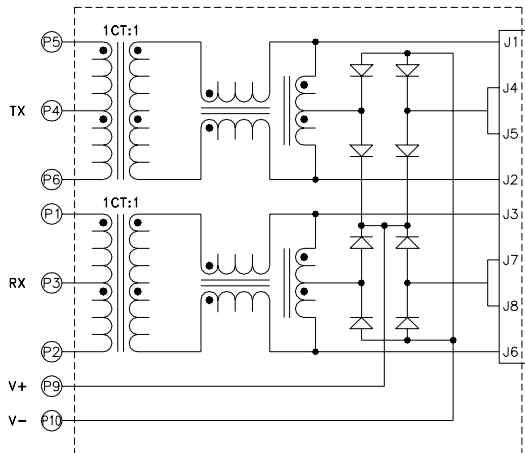

**Part Number LED (left-right) Tab Direction EMI Tabs**  
MIC66611-5171 Yellow-Green Down No

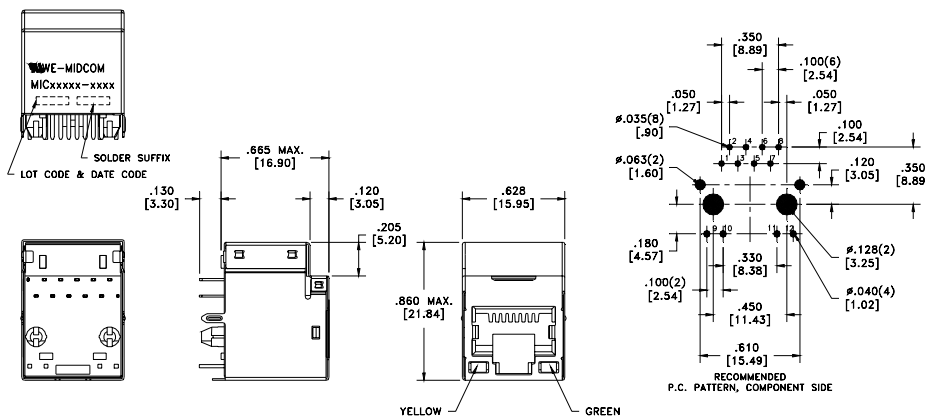

5/01/08 Details subject to change. Contact your Midcom sales representative for additional information. Dimensions: in/mm. All tolerances are ± .010/0,25 and electrical specifications are @ 25°C unless otherwise specified.

Würth Electronics Midcom, Inc. USA  
121 Airport Drive - PO Box 1330  
Watertown, SD 57201  
T: 605.886.4385 ~ F: 605.886.4486  
www.we-online.com ~ email:sales@midcom-inc.com

# Integrated 10 Base-T RJ45 Through Hole Series

## Common Electrical Characteristics

Inductance	200uH min.	20mVrms, 100kHz
Dielectric Rating	1500VAC	for 1 minute
Capacitance	20pF max.	20mVrms, 100kHz
D.C. Resistance	0.9Ω max.	each winding

## Features

- Optional pin-outs and LEDs
- Industry standard connector footprint
- Optimum performance
- Cost effective
- Both RoHS compliant and lead-terminal parts available
- Operating temperature range 0°C to +70°C.

Part Number	LED (left-right)	Tab Direction	EMI Tabs	Transmit Turns Ratio	Receive Turns Ratio	Lkg Ind. (μH)	Schematic
MIC13011-5113	Yellow-Green	Down	Yes	1CT:1.4	1CT:1	0.55 max.	1
MIC13013-5121	Green-Yellow	Down	Yes	1CT:2.5	1CT:1	0.50 max.	2
MIC13011-0111	Yellow-Green	Down	Yes	1CT:2.5	1CT:1	0.50 max.	1

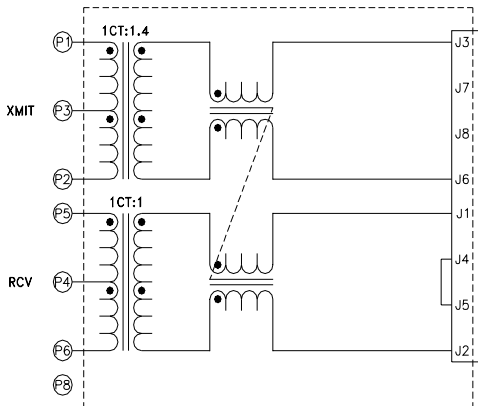

Schematic 1

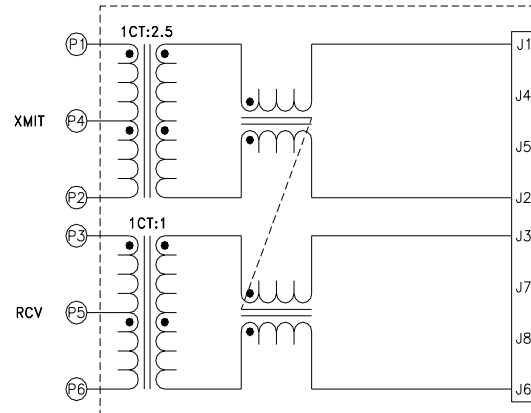

Schematic 2

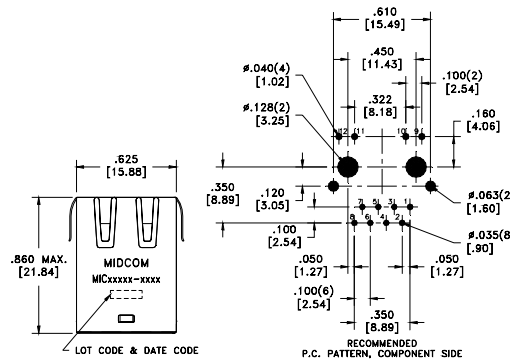
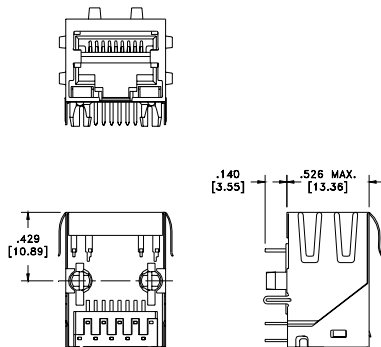

Details subject to change. Contact your Midcom sales representative for additional information. Dimensions: in/mm. All tolerances are ± .010/0.25 and electrical specifications are @ 25°C unless otherwise specified.

## Integrated 10/100 Base-T RJ45 Through Hole MIC24 Series



LANDatacom

### Typical Electrical Characteristics<sup>1</sup>

Inductance	350uH Min.	0.1Vrms, 100kHz, 8mADC
Dielectric Rating	1500VAC	for 1 minute
Turns Ratio	1CT:1CT	±2%
Insertion Loss	-1.0dB max.	1MHz-100MHz
Return Loss	-18dB min.	1MHz-30MHz
	-16dB min.	30MHz-45MHz
	-14dB min.	45MHz-60MHz
	-12dB min.	60MHz-80MHz
Cross Talk	-35dB min.	1MHz-100MHz
Common Mode Rejection	-35dB min.	1MHz-100MHz

Note1: Characteristics for individual parts may vary slightly; see specification sheet for actual values.

### Features

- Optional PoE compatible designs
- Optional pin-outs and LEDs
- Industry standard connector foot-print
- Optimum performance
- Cost effective
- Both RoHS compliant and lead-terminal parts available

Part Number	LED (left-right)	Tab Direction	EMI Tabs	Operating	Schematic	Mechanical
				Temp. Range		
MIC24010-5101	None	Down	Yes	0°C to +70°C	1	1
MIC24010-5104	None	Down	Yes	0°C to +70°C	2	1
MIC24010-0107	None	Down	Yes	-40°C to +85°C	3	1
MIC24011-0101	Yellow -Green	Down	Yes	0°C to +70°C	1	1
MIC24011-0104	Yellow -Green	Down	Yes	0°C to +70°C	2	1
MIC24011-5108	Yellow -Green	Down	Yes	-40°C to +85°C	1	1
MIC24012-5101	Green-Green	Down	Yes	0°C to +70°C	1	1
MIC24012-5204	Green-Green	Down	Yes	0°C to +70°C	2	1
MIC24012-5117	Green-Green	Down	Yes	-40°C to +85°C	2	1
MIC2401D-5101	Green/Yellow -Green/Yellow	Down	Yes	0°C to +70°C	1	1
MIC2401D-5217	Green/Yellow -Green/Yellow	Down	Yes	-40°C to +85°C	2	1
MIC24013-0102	Green-Yellow	Down	Yes	0°C to +70°C	4	1
MIC24013-5204	Green-Yellow	Down	Yes	0°C to +70°C	2	1
MIC24013-5104	Green-Yellow	Down	Yes	0°C to +70°C	2	7
MIC24018-5101	Red-Green	Down	Yes	0°C to +70°C	1	1
MIC24019-0101	Green-Red	Down	Yes	0°C to +70°C	1	1
74990110010	None	Up	Yes	-40°C to +85°C	2	9
MIC24111-0101	Yellow -Green	Up	Yes	0°C to +70°C	1	2
MIC24112-0101	Green-Green	Up	Yes	0°C to +70°C	1	2
MIC24111-0108	Yellow -Green	Up	Yes	-40°C to +85°C	1	2
74990112116	Green-Yellow	Up	Yes	-40°C to +85°C	1	2
MIC2411C-6131	Yellow -Orange/Green	Up	Yes	0°C to +70°C	6	8
MIC2411D-0117	Green/Yellow -Green/Yellow	Up	Yes	-40°C to +85°C	2	2
MIC24210-0101	None	Down	No	0°C to +70°C	1	3
MIC24210-0104	None	Down	No	0°C to +70°C	2	3
MIC24211-5101	Yellow -Green	Down	No	0°C to +70°C	1	3
MIC24212-5104	Green-Green	Down	No	0°C to +70°C	2	3
MIC24213-5101	Green-Yellow	Down	No	0°C to +70°C	1	3
MIC24213-5204	Green-Yellow	Down	No	0°C to +70°C	2	6
MIC24310-5101	None	Up	No	0°C to +70°C	1	5
MIC24311-0101	Yellow -Green	Up	No	0°C to +70°C	1	4
MIC24313-0101	Green-Yellow	Up	No	0°C to +70°C	1	4
7499010214	Green-Yellow	Up	No	0°C to +70°C	5	4

5/01/08 Details subject to change. Contact your Midcom sales representative for additional information. Dimensions: in/mm. All tolerances are ±.010/0.25 and electrical specifications are @ 25°C unless otherwise specified.

Würth Electronics Midcom, Inc. USA  
121 Airport Drive - PO Box 1330  
Watertown, SD 57201  
T: 605.886.4385 - F: 605.886.4486  
www.we-online.com - email:sales@midcom-inc.com

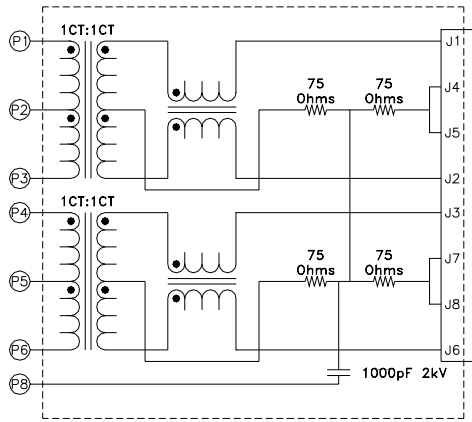

Schematic 1

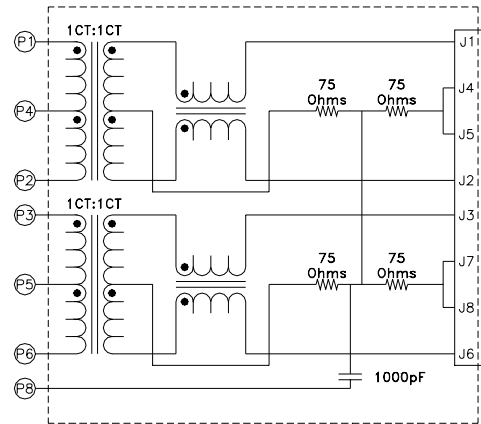

Schematic 2

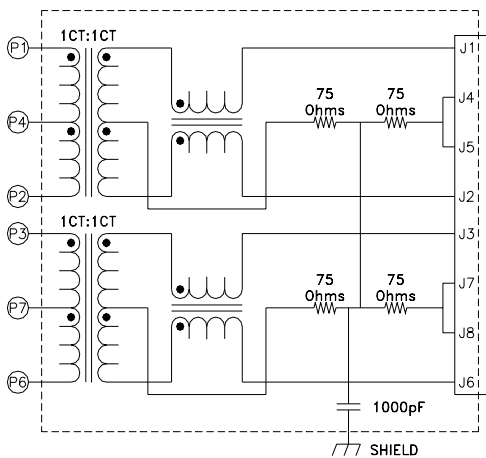

Schematic 3

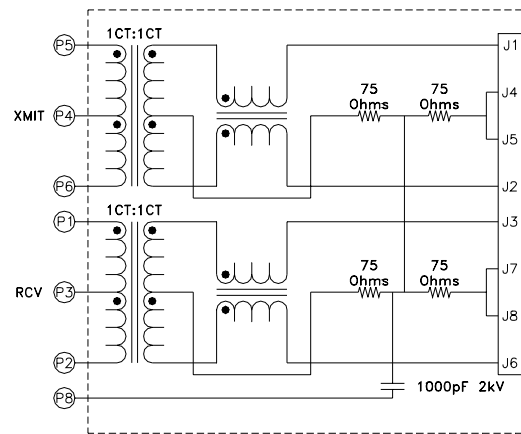

Schematic 4

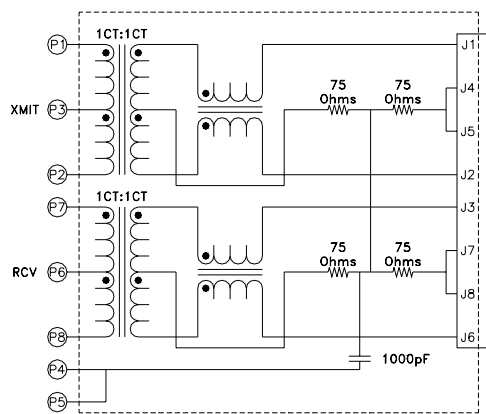

Schematic 5

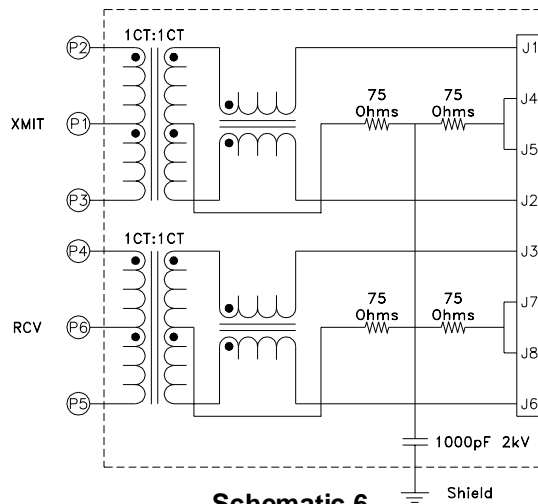

Schematic 6



Integrated 10/100 Base-T RJ45  
Through Hole MIC24 Series

LANDatacom

### M1 - Tab Down with EMI Tabs

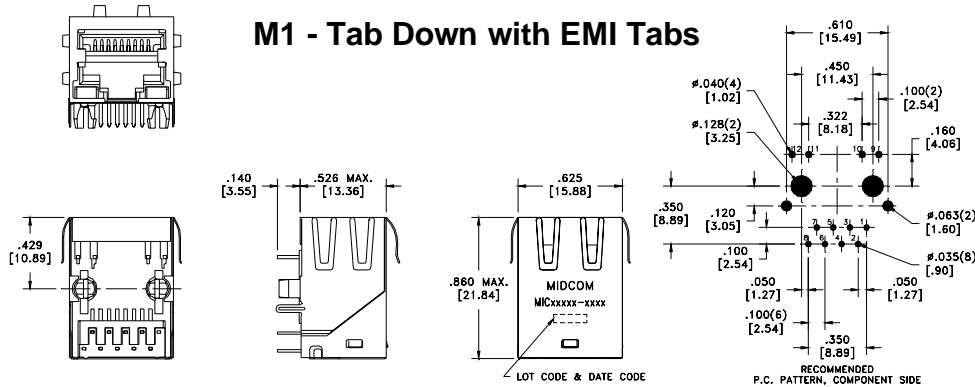

### M2 - Tab Up with EMI Tabs

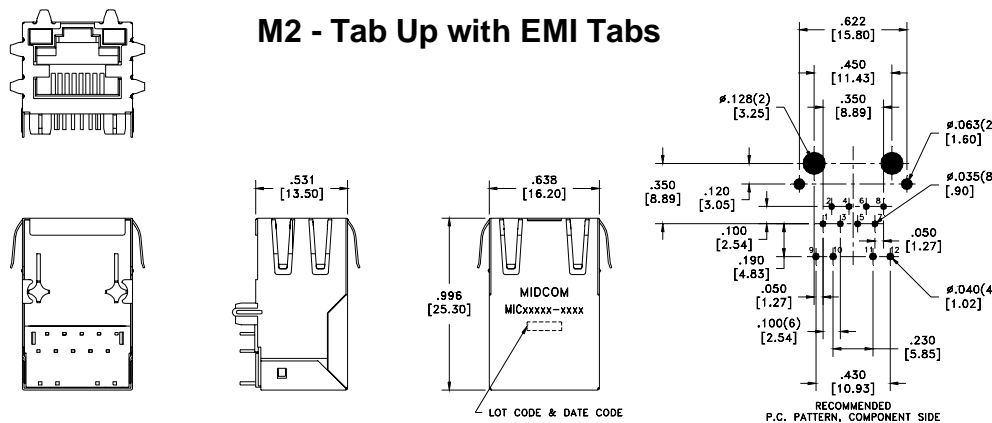

### M3 - Tab Down without EMI Tabs

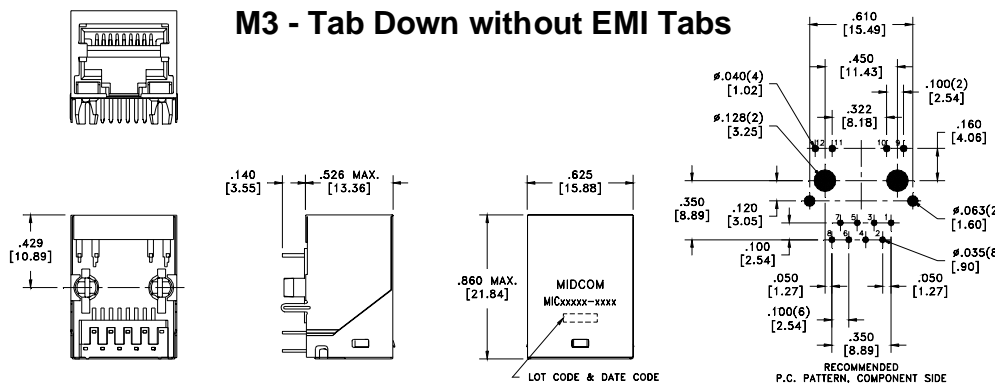

5/01/08 Details subject to change. Contact your Midcom sales representative for additional information. Dimensions: in/mm. All tolerances are ± .010/0.25 and electrical specifications are @ 25°C unless otherwise specified.

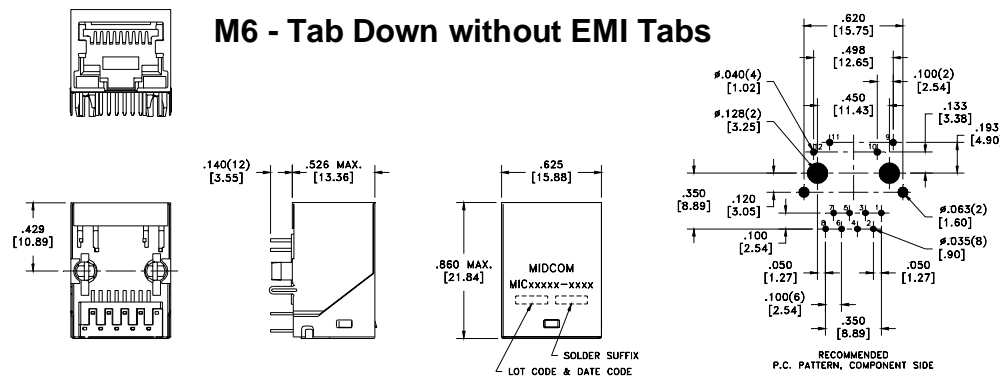
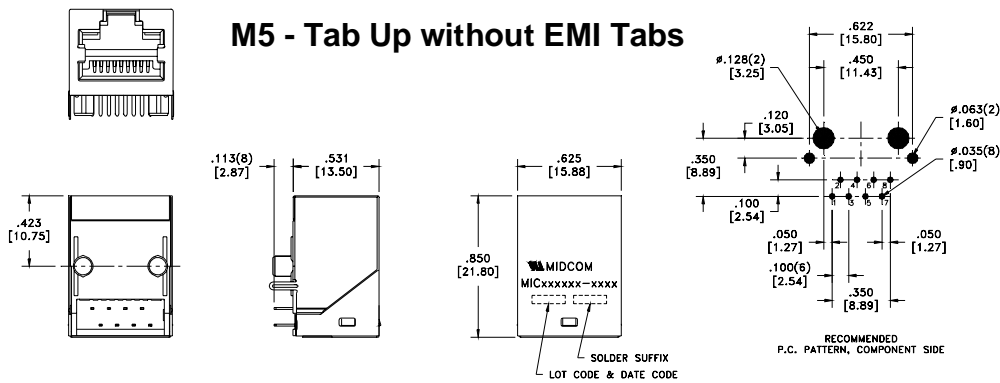
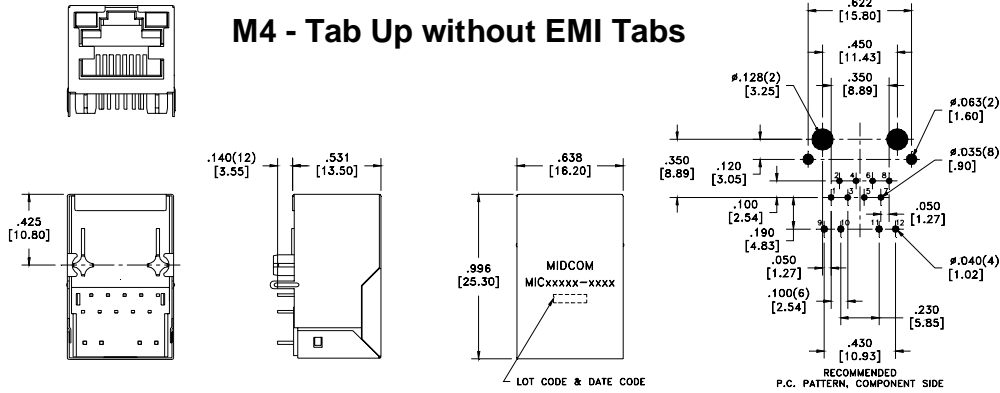

Details subject to change. Contact your Midcom sales representative for additional information. Dimensions: in/mm. All tolerances are ± .010/0.25 and electrical specifications are @ 25°C unless otherwise specified.



Integrated 10/100 Base-T RJ45  
Through Hole MIC24 Series

**Midcom**

LANDatacom

### M7 - Tab Down with EMI Tabs

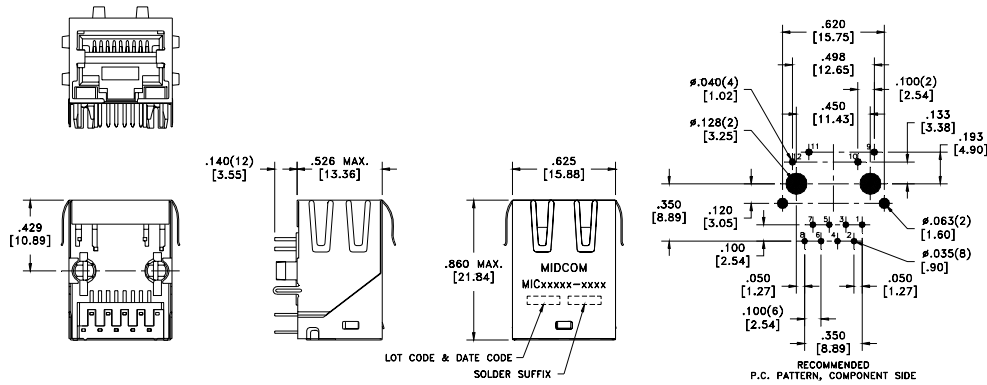

### M8 - Tab Up with EMI Tabs

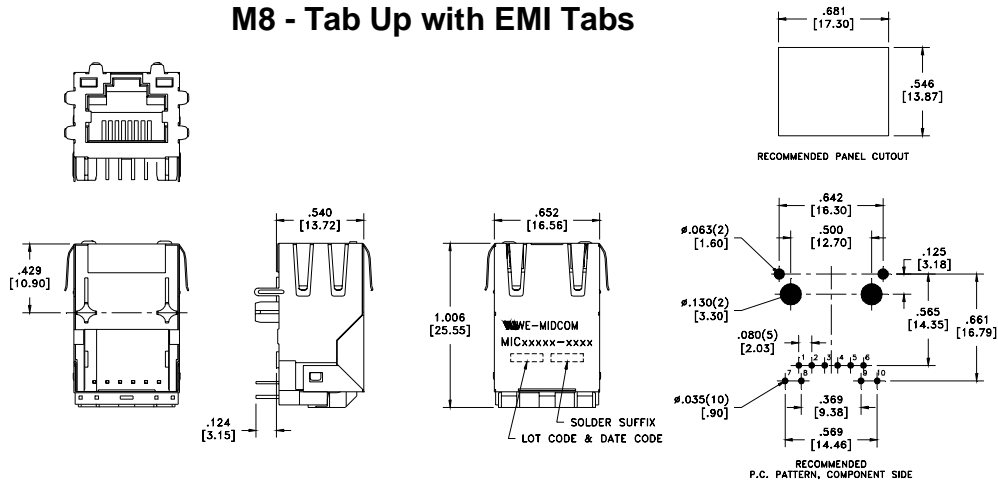

### M9 - Tab Up with EMI Tabs

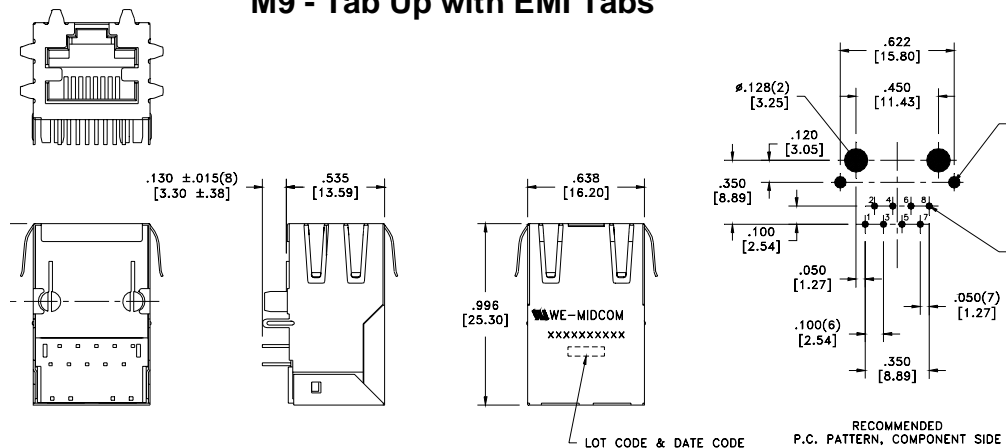

5/01/08 Details subject to change. Contact your Midcom sales representative for additional information. Dimensions: in/mm. All tolerances are ±.010/0,25 and electrical specifications are @ 25°C unless otherwise specified.

**Electrical Characteristics**

Inductance	350uH Min.	0.1Vrms, 100kHz, 8mADC
Dielectric Rating	1500VAC	for 1 minute
Turns Ratio	1CT:1	±2%
Insertion Loss	-1.0dB max.	1MHz-100MHz
Return Loss	-18dB min.	1MHz-30MHz
	-16dB min.	30MHz-45MHz
	-14dB min.	45MHz-60MHz
	-12dB min.	60MHz-80MHz
Cross Talk	-35dB min.	1MHz-100MHz
Common Mode Rejection	-35dB min.	1MHz-100MHz

Note1: Electrical Characteristics for individual part may vary; see specification sheet for actual values.

**Features**

- Through hole
- AutoMDIX compatible
- PoE compatible (designed for 350mADC and 802.3af)
- Operating Temperature 0°C to 70°C
- Optional pin-outs and LEDs
- Industry standard connector footprint
- Optimum performance
- Cost Effective
- RoHS compliant

Part Number	LED (left-right)	Tab Direction	EMI Tabs	Operating Temp. Range	Schematic	Mechanical
MIC24611-5104	Yellow-Green	Down	No	0°C to +70°C	S1	M1
7499010219	Green-Yellow	Down	No	0°C to +70°C	S2	M1
MIC24611-5117	Yellow-Green	Down	No	0°C to +70°C	S1	M2

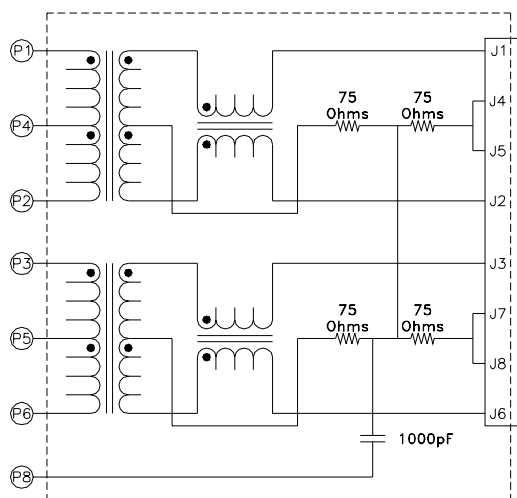

Schematic 1

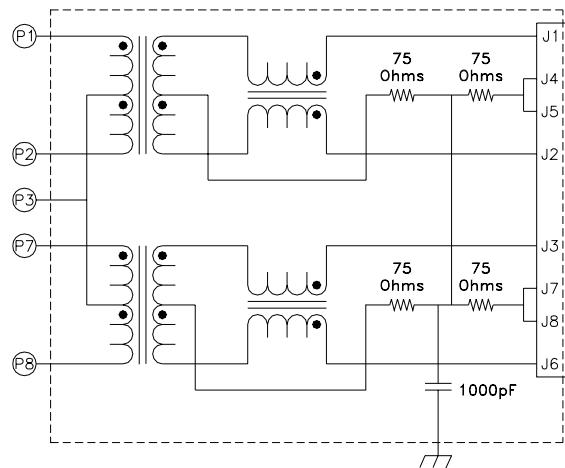

Schematic 2



Integrated 10/100 Base-T RJ45  
Vertical Through Hole



LANDatacom

### Mechanical—M1

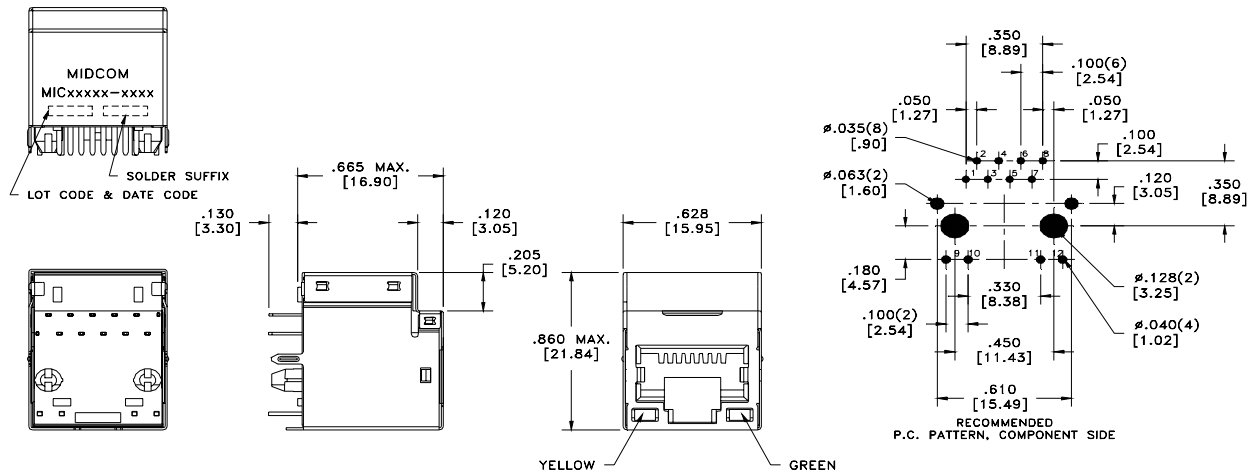

### Mechanical—M2

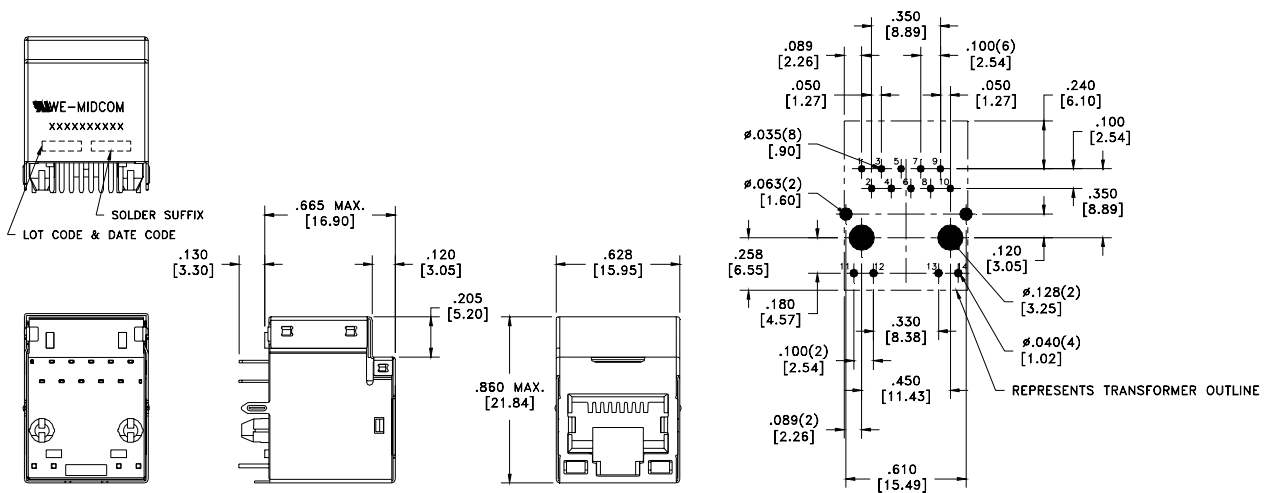

5/01/08 Details subject to change. Contact your Midcom sales representative for additional information. Dimensions: in/mm. All tolerances are ± .010/0,25 and electrical specifications are @ 25°C unless otherwise specified.

Typical Electrical Characteristics<sup>1</sup>

Inductance	350uH Min.	0.1Vrms, 100kHz, 8mADC
Dielectric Rating	1500VAC	for 1 minute
Turns Ratio	1CT:1CT	±2%
Insertion Loss	-1.0dB max.	1MHz-100MHz
Return Loss	-18dB min.	1MHz-30MHz
	-16dB min.	30MHz-45MHz
	-14dB min.	45MHz-60MHz
	-12dB min.	60MHz-80MHz
Cross Talk	-35dB min.	1MHz-100MHz
Common Mode Rejection	-35dB min.	1MHz-100MHz

Note1: Electrical Characteristics for individual part may vary; see specification sheet for actual values.

Features

- Optional PoE compatible designs
- Optional pin-outs and LEDs
- Industry standard connector footprint
- Optimum performance
- Cost effective
- Both RoHS compliant and lead-terminal parts available

Part Number	LED (left-right)	Tab Direction	Operating Temp. Range	Mechanical	Schematic
MIC24412-0128	Green-Green	Up	0°C to +70°C	1	1
MIC24F11-0101	Yellow-Green	Up	0°C to +70°C	2	2
7499012000	None	Down	0°C to +70°C	3	3

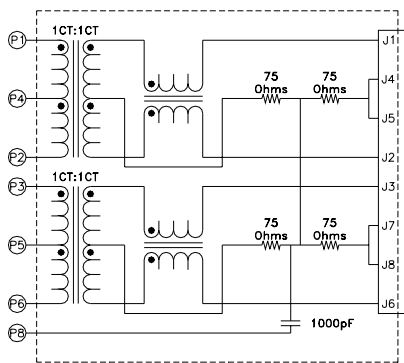

Schematic 1

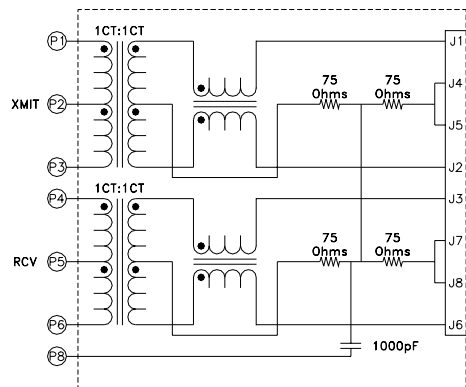

Schematic 2

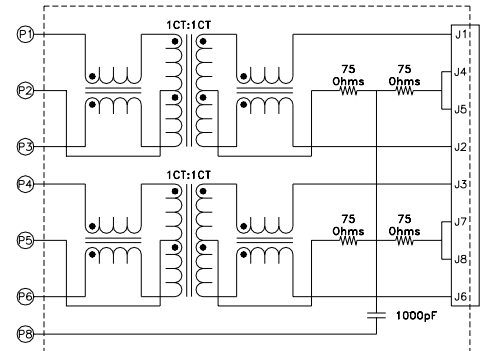

Schematic 3

Details subject to change. Contact your Midcom sales representative for additional information. Dimensions: in/mm. All tolerances are ± .010/0.25 and electrical specifications are @ 25°C unless otherwise specified.

Integrated 10/100 Base-T RJ45  
Through Hole Unshielded Series



LANDatacom

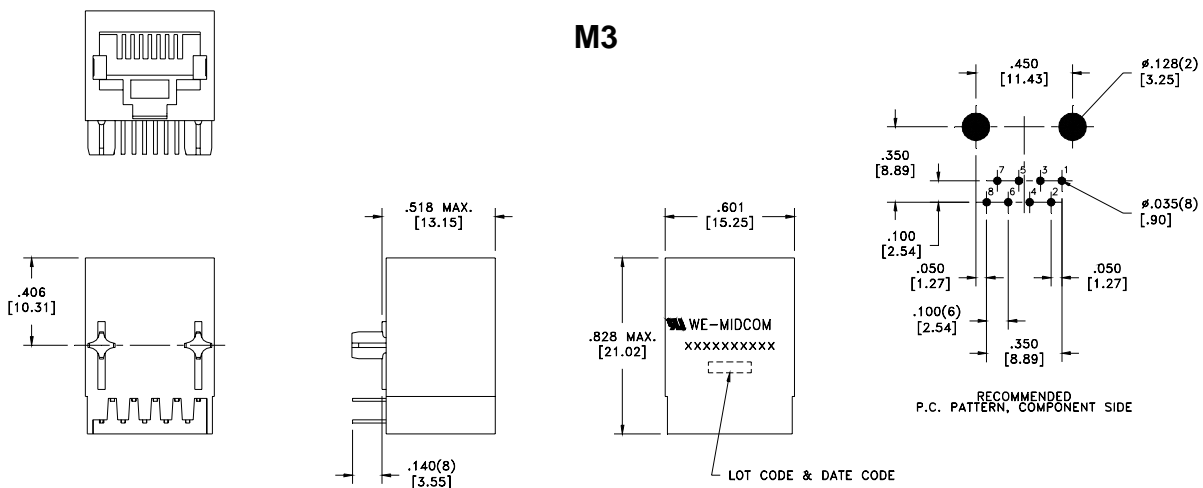
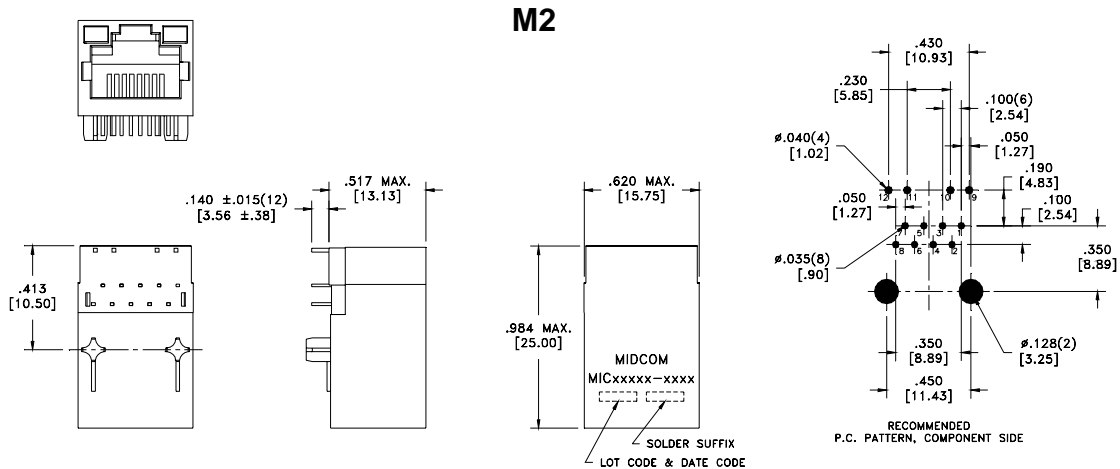
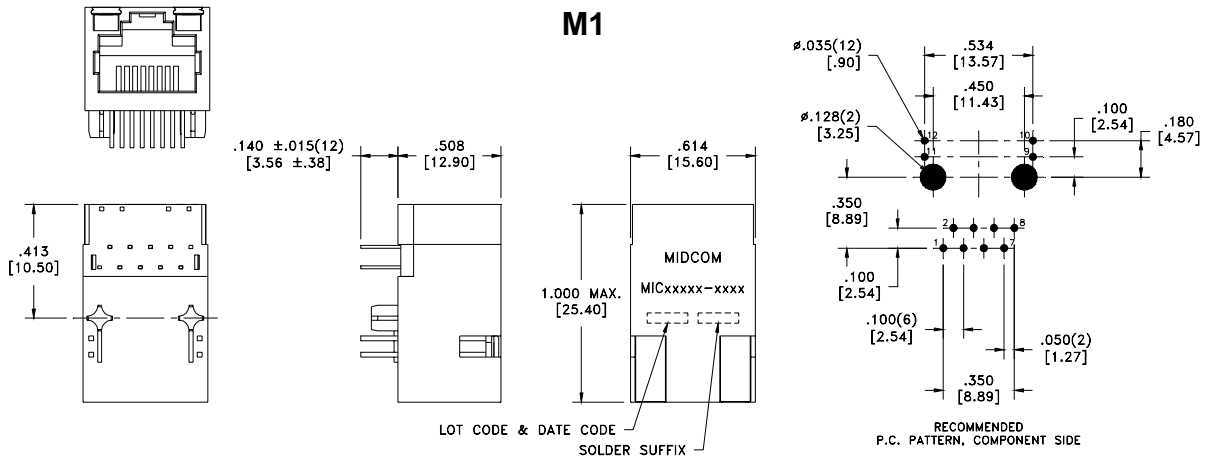

5/01/08 Details subject to change. Contact your Midcom sales representative for additional information. Dimensions: in/mm. All tolerances are ± .010/0,25 and electrical specifications are @ 25°C unless otherwise specified.

**Integrated 10/100 Base-T RJ45  
Through Hole MIC24 Series with Protection**



LANDatacom

**Typical Electrical Characteristics**

Inductance	350uH Min.	0.1Vrms, 100kHz, 8mA DC
Dielectric Rating	1500VAC	for 1 minute
Turns Ratio	1CT:1CT	±2%
Insertion Loss	-1.0dB max.	1MHz-100MHz
Return Loss	-18dB min.	1MHz-30MHz
	-16dB min.	30MHz-45MHz
	-14dB min.	45MHz-60MHz
	-12dB min.	60MHz-80MHz
Cross Talk	-35dB min.	1MHz-100MHz
Common Mode Rejection	-35dB min.	1MHz-100MHz

**Features**

- Optional PoE compatible designs
- Optional pin-outs and LEDs
- Industry standard connector footprint
- Optimum performance
- Cost effective
- Both RoHS compliant and lead-terminal parts available

Part Number	LED (left-right)	Tab Direction	EMI Tabs	Operating Temp. Range
MIC24113-0118	Green-Yellow	Up	Yes	0°C to +70°C

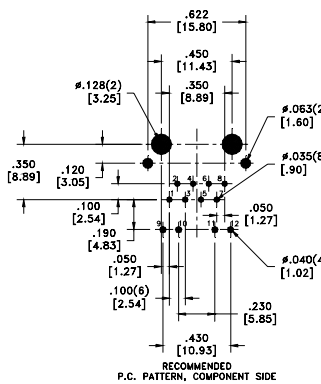
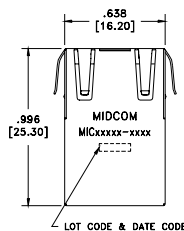
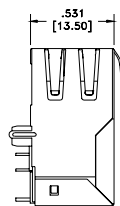
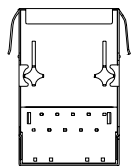
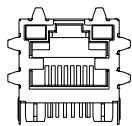
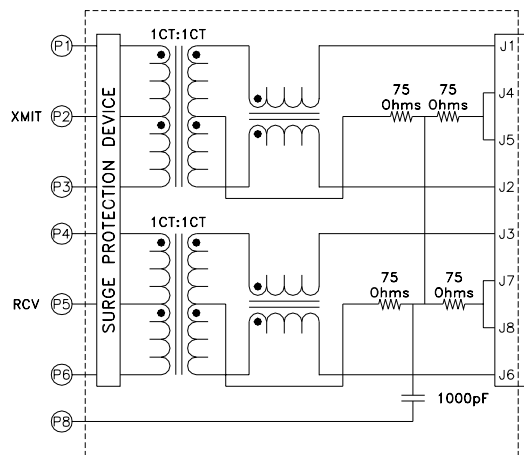

Details subject to change. Contact your Midcom sales representative for additional information. Dimensions: in/mm. All tolerances are ± .010/0.25 and electrical specifications are @ 25°C unless otherwise specified.

## Integrated 10/100 Base-T RJ45 Surface Mount MIC24 Series

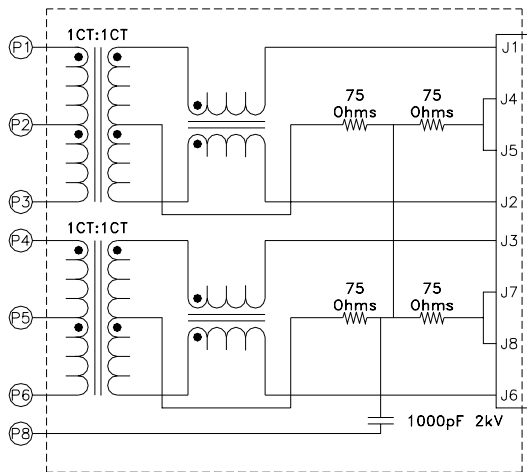

### Features

- Surface Mount
- AutoMDIX compatible
- Optional PoE compatible designs
- Optional pin-outs
- Industry standard connector footprint
- Optimum performance
- Cost Effective
- Both RoHS compliant and lead-terminal parts available

Part Number	LED (left-right)	Tab Direction	EMI Tabs	Temp Range	Mechanical
MIC24020-5101	None	Down	Yes	0°C to 70°C	1
MIC24120-5101	None	Up	Yes	0°C to 70°C	2
MIC24121-5101	Yellow-Green	Up	Yes	0°C to 70°C	3
MIC24122-5101	Green-Green	Up	Yes	0°C to 70°C	3
MIC2412A-5108	Green-Green/Yellow	Up	Yes	-40°C to 85°C	3

### Electrical Characteristics

Inductance	350uH Min.	0.1Vrms, 100kHz, 8mADC
Dielectric Rating	1500VAC	for 1 minute
Turns Ratio	1CT:1CT	±2%
Insertion Loss	-1.0dB max.	1MHz-100MHz
Return Loss	-18dB min.	1MHz-30MHz
	-16dB min.	30MHz-45MHz
	-14dB min.	45MHz-60MHz
	-12dB min.	60MHz-80MHz
Cross Talk	-35dB min.	1MHz-100MHz
Common Mode Rejection	-35dB min.	1MHz-100MHz

# Integrated 10/100 Base-T RJ45 Surface Mount MIC24 Series Mechanicals

## Mechanical 1

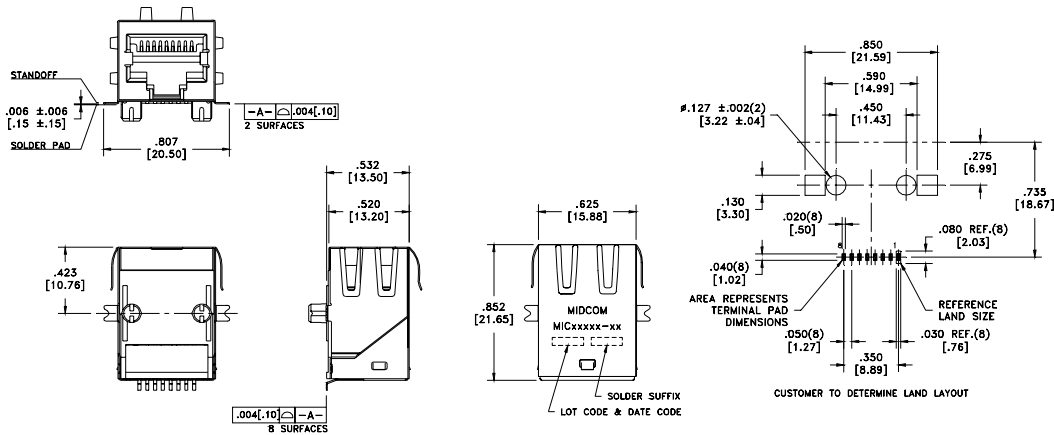

## Mechanical 2

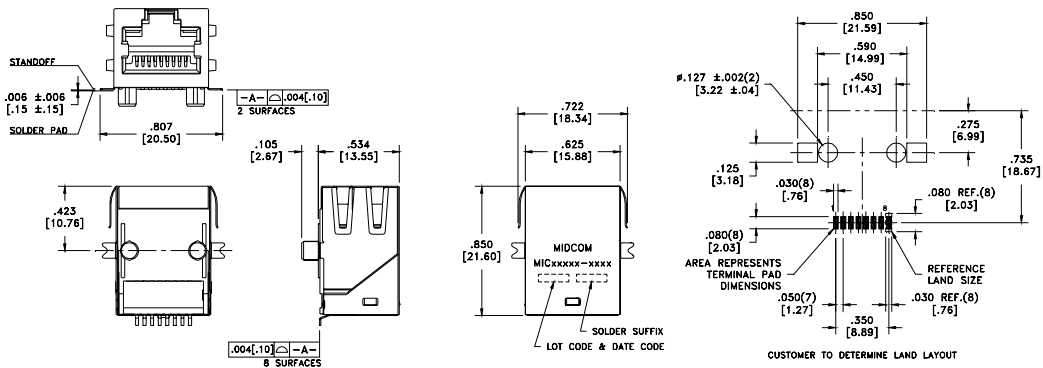

## Mechanical 3

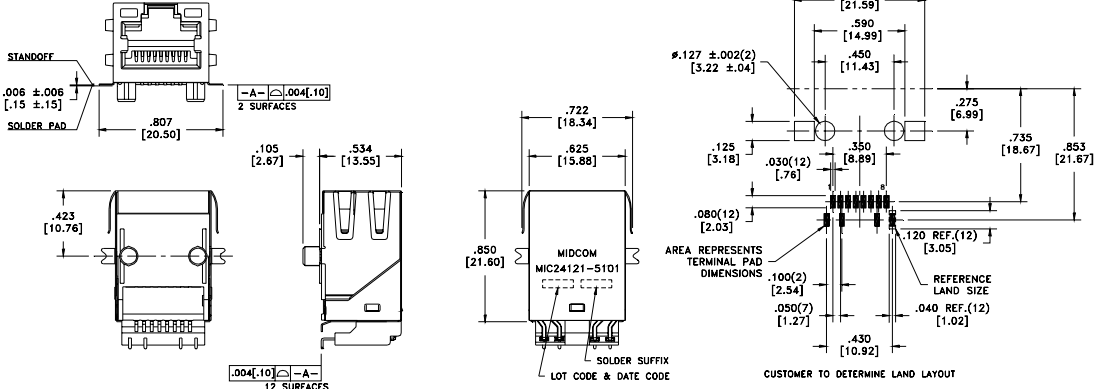

Details subject to change. Contact your Midcom sales representative for additional information. Dimensions: in/mm. All tolerances are ± .010/0.25 and electrical specifications are @ 25°C unless otherwise specified.

## Integrated 10/100 Base-T RJ45 Through Hole MIC25 Series



LANDatacom

### Electrical Characteristics

Inductance	350uH Min.	0.1Vrms, 100kHz, 8mADC
Dielectric Rating	1500VAC	for 1 minute
Turns Ratio	1CT:1CT	±2%
Insertion Loss	-1.0dB max.	1MHz-100MHz
Return Loss	-18dB min.	1MHz-30MHz
	-16dB min.	30MHz-45MHz
	-14dB min.	45MHz-60MHz
	-12dB min.	60MHz-80MHz
Cross Talk	-33dB min.	1MHz-100MHz
Common Mode Rejection	-35dB min.	1MHz-100MHz

### Features

- Optional pin-outs and LEDs
- Industry standard footprint
- Optimum performance
- Cost effective
- RoHS compliant

Part Number	LED (left-right)	Tab Direction	EMI Tabs	Operating	
				Temp. Range	Schematic Mechanical
MIC25010-5110	None	Down	Yes	0°C to +70°C	2 1
MIC25010-5101	None	Down	Yes	0°C to +70°C	4 1
MIC25011-5110	Yellow-Green	Down	Yes	0°C to +70°C	2 1
MIC25013-5110	Green-Yellow	Down	Yes	0°C to +70°C	2 1
MIC25013-5223	Green-Yellow	Down	Yes	0°C to +70°C	5 5
7499011219	Green-Yellow	Down	Yes	0°C to +70°C	7 5
74990112112	Green-Yellow	Down	Yes	-40°C to +85°C	5 5
MIC2501A-5110	Green-Green/Yellow	Down	Yes	0°C to +70°C	2 1
MIC25113-0141	Green-Yellow	Up	Yes	0°C to +70°C	3 2
MIC2511C-6131	Green/Orange-Yellow	Up	Yes	0°C to +70°C	6 8
MIC25210-0101	None	Down	No	0°C to +70°C	1 3
MIC25211-5112	Yellow-Green	Down	No	-40°C to +85°C	2 3
MIC25212-0110	Green-Green	Down	No	0°C to +70°C	2 3
MIC25213-5210	Green-Yellow	Down	No	0°C to +70°C	2 6
MIC25310-5110	None	Up	No	0°C to +70°C	2 7
MIC25311-0110	Yellow-Green	Up	No	0°C to +70°C	2 4
7499010218	Green-Yellow	Up	No	0°C to +70°C	2 4

5/01/08 Details subject to change. Contact your Midcom sales representative for additional information. Dimensions: in/mm. All tolerances are ±.010/0.25 and electrical specifications are @ 25°C unless otherwise specified.

Würth Electronics Midcom, Inc. USA  
121 Airport Drive - PO Box 1330  
Watertown, SD 57201  
T: 605.886.4385 ~ F: 605.886.4486  
www.we-online.com ~ email:sales@midcom-inc.com

**Integrated 10/100 Base-T RJ45  
Through Hole MIC25 Series**



LANDatacom

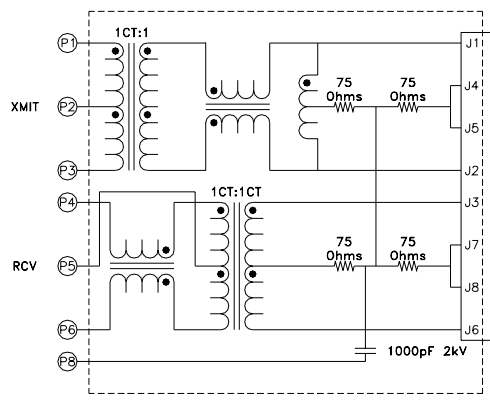

**Schematic 1**

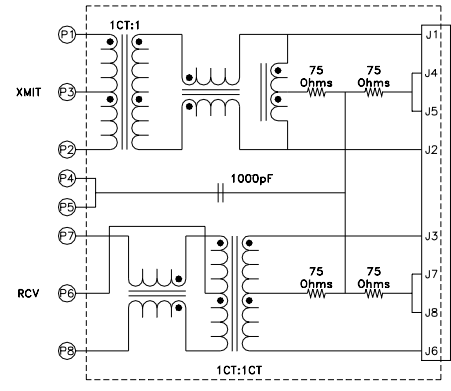

**Schematic 2**

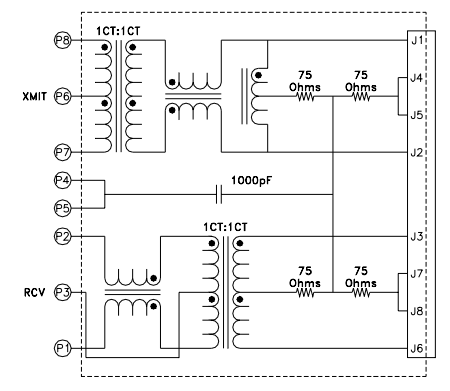

**Schematic 3**

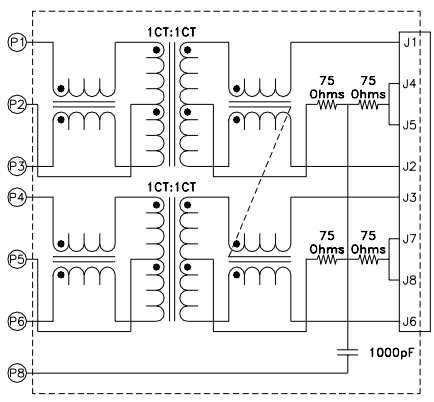

**Schematic 4**

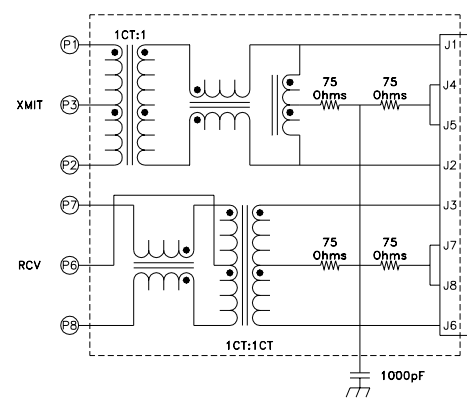

**Schematic 5**

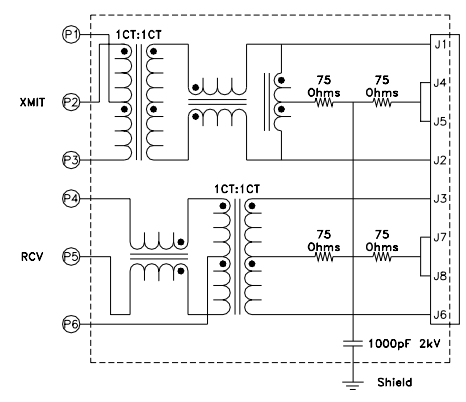

**Schematic 6**

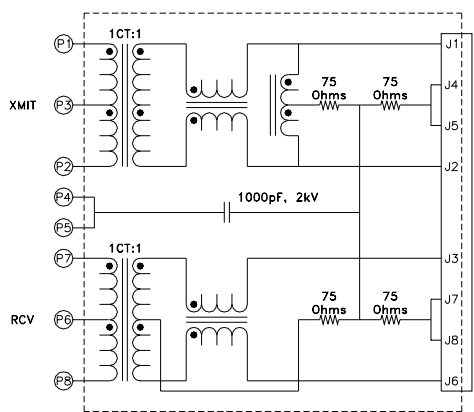

**Schematic 7**

Details subject to change. Contact your Midcom sales representative for additional information. Dimensions: in/mm. All tolerances are ± .010/0.25 and electrical specifications are @ 25°C unless otherwise specified.



# Integrated 10/100 Base-T RJ45 Through Hole MIC25 Series



LANDatacom

## M1 - Tab Down with EMI Tabs

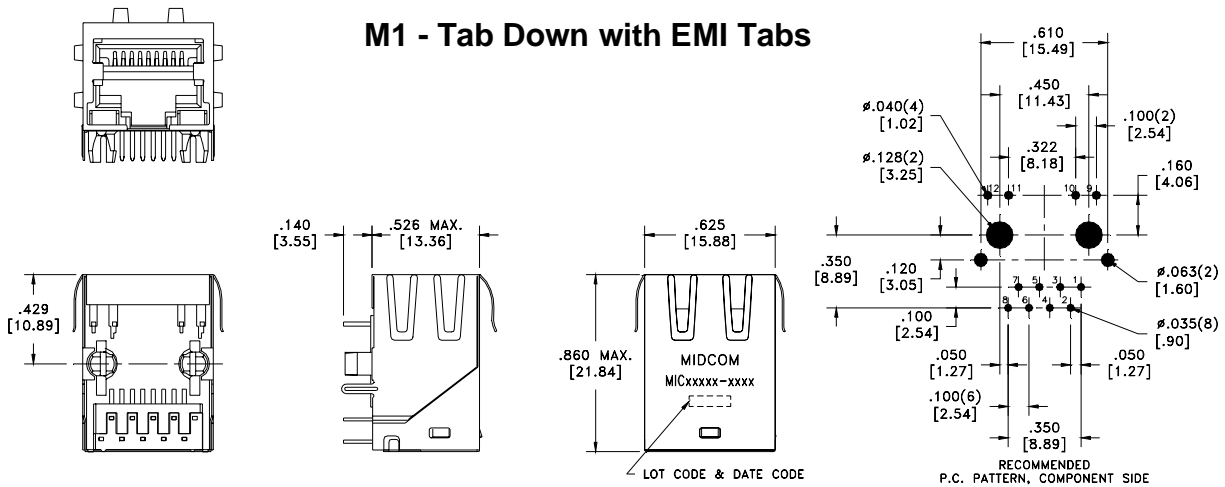

## M2 - Tab Up with EMI Tabs

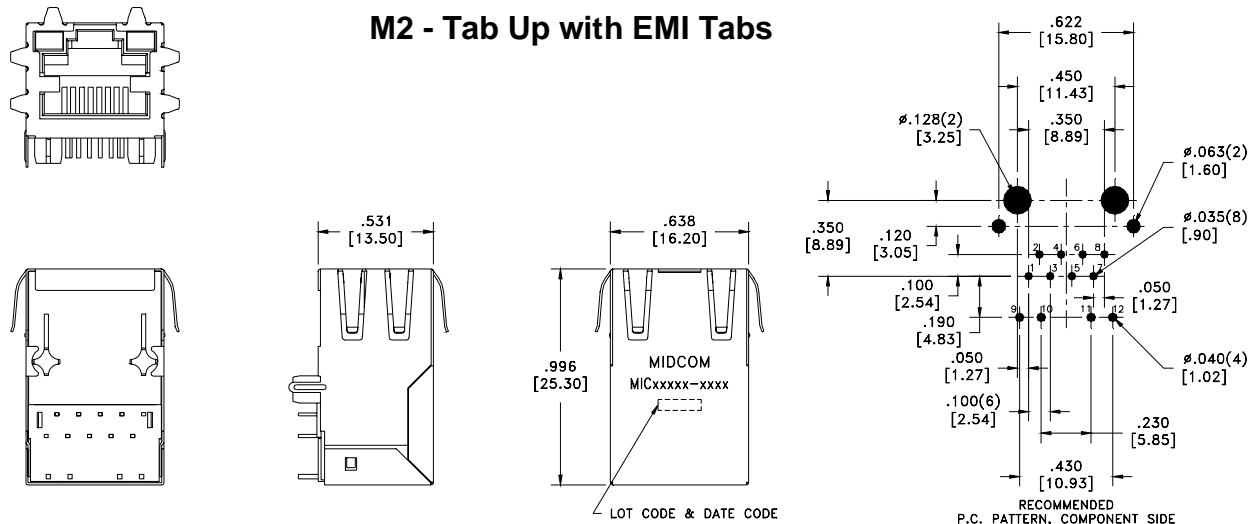

## M3 - Tab Down without EMI Tabs

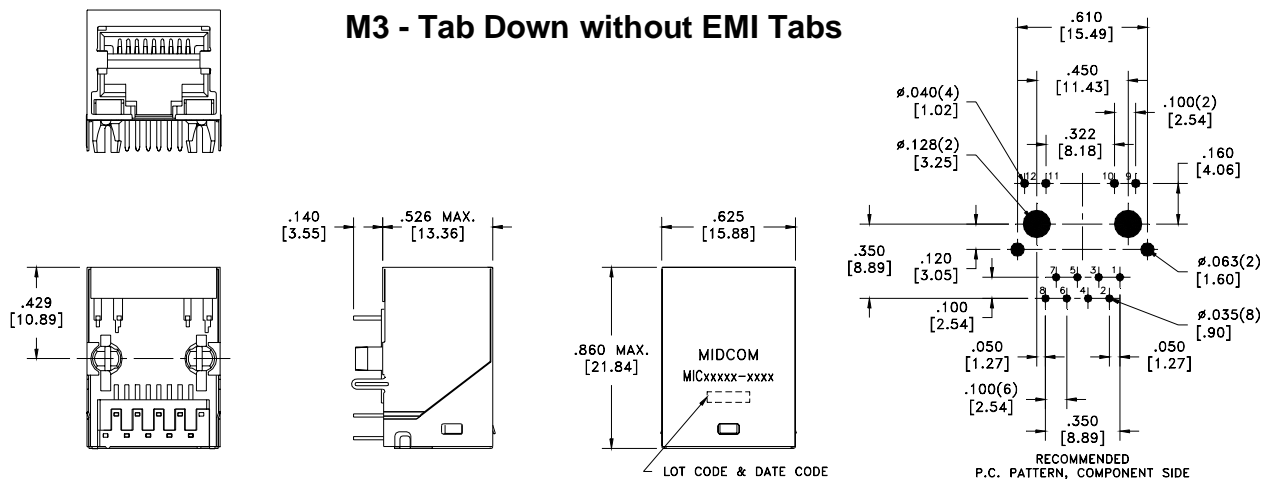

5/01/08 Details subject to change. Contact your Midcom sales representative for additional information. Dimensions: in/mm. All tolerances are ± .010/0,25 and electrical specifications are @ 25°C unless otherwise specified.

**Integrated 10/100 Base-T RJ45  
Through Hole MIC25 Series**



**LANDatacom**

**M4 - Tab Up without EMI Tabs**

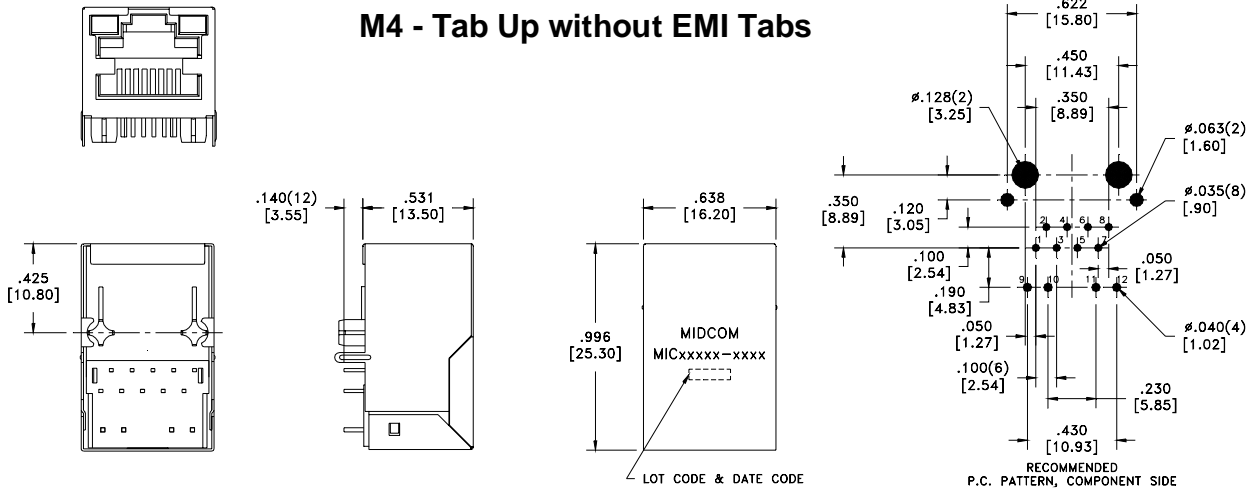

**M5 - Tab Down with EMI Tabs**

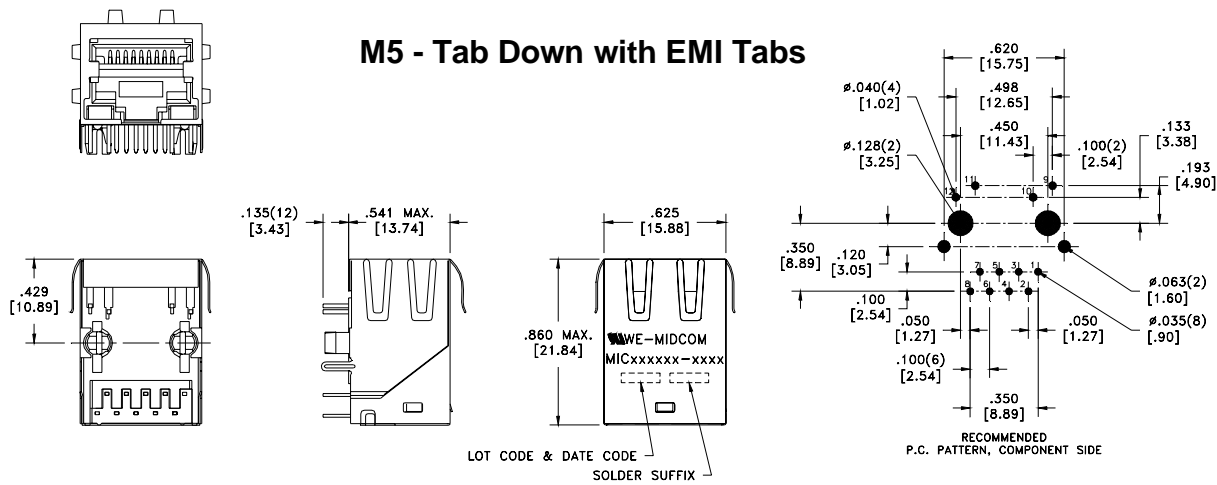

**M6 - Tab Down without EMI Tabs**

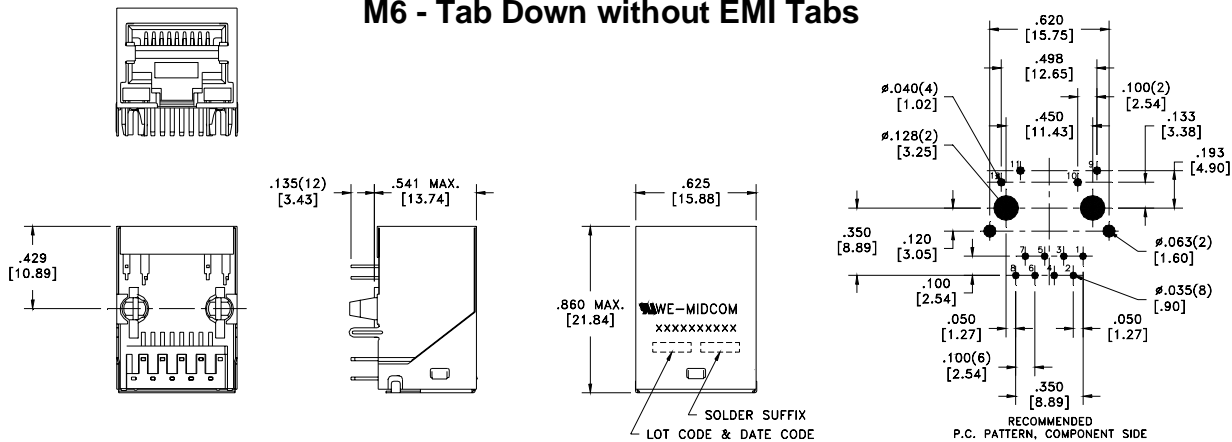

Details subject to change. Contact your Midcom sales representative for additional information. Dimensions: in/mm. All tolerances are ± .010/0.25 and electrical specifications are @ 25°C unless otherwise specified.

### M7 - Tab Up without EMI Tabs

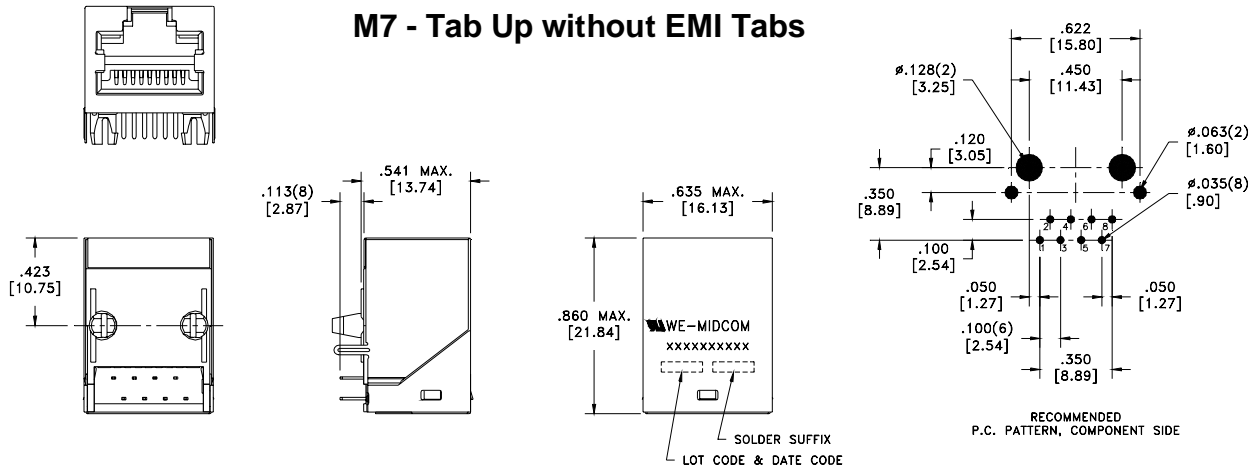

### M8 - Tab Up with EMI Tabs

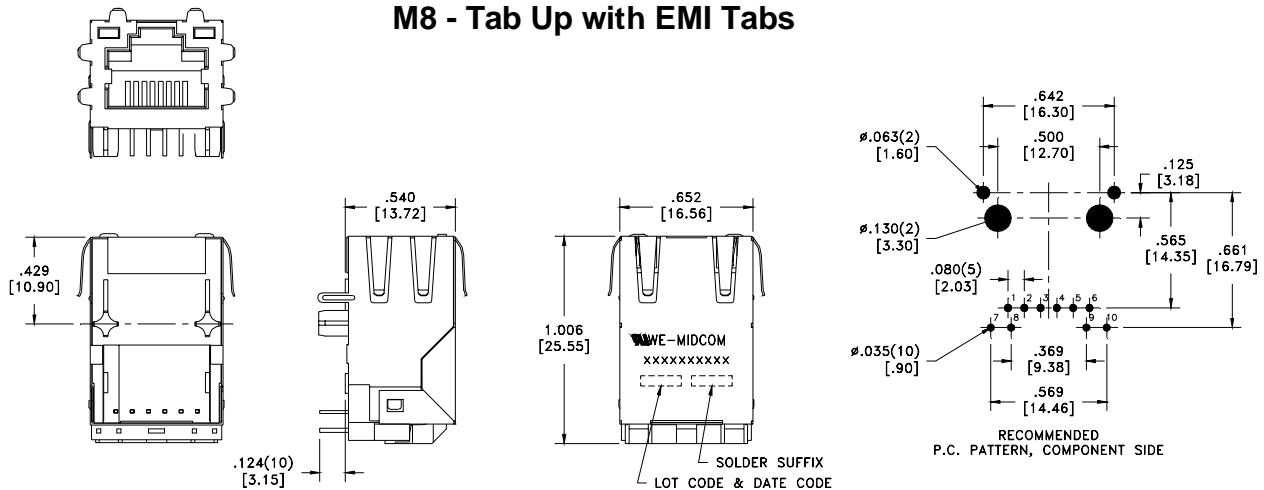

**Integrated 10/100 Base-T RJ45  
Through Hole MIC26 Series**



LANDatacom

**Features**

- Optional pin-outs and LEDs
- Industry standard connector footprint
- Optimum performance
- Cost effective
- Both RoHS compliant and lead-terminal parts available

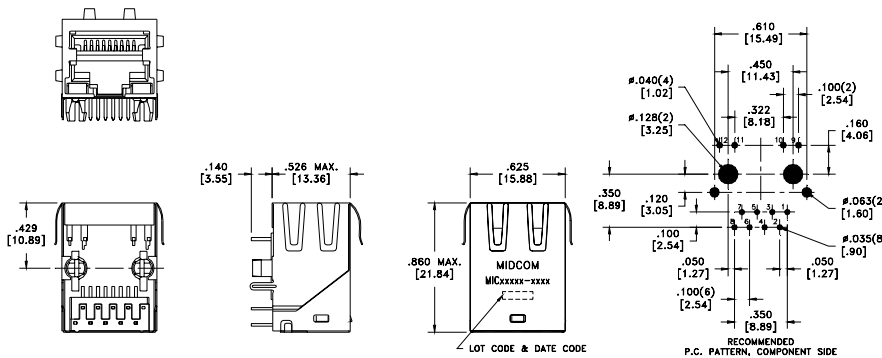

**Operating**

Part Number	LED (left-right)	Tab Direction	EMI Tabs	Temp. Range
MIC26010-5101	None	Down	Yes	0°C to +70°C

**Electrical Characteristics**

Inductance	350uH Min.	0.1Vrms, 100kHz, 8mADC
Dielectric Rating	1500VAC	for 1 minute
Turns Ratio	1CT:1CT	±2%
Insertion Loss	-1.0dB max.	1MHz-100MHz
Return Loss	-18dB min.	1MHz-30MHz
	-16dB min.	30MHz-45MHz
	-14dB min.	45MHz-60MHz
	-12dB min.	60MHz-80MHz
Cross Talk	-35dB min.	1MHz-100MHz
Common Mode Rejection	-35dB min.	1MHz-100MHz

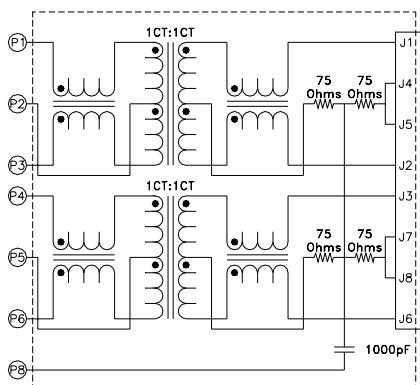

Details subject to change. Contact your Midcom sales representative for additional information. Dimensions: in/mm. All tolerances are ± .010/0.25 and electrical specifications are @ 25°C unless otherwise specified.

5/01/08

Integrated 10/100 Base-T RJ45  
Low Profile Surface Mount



LANDatacom

**Electrical Characteristics**

Inductance	350uH Min.	0.1Vrms, 100kHz, 8mADC
Turns Ratio	1CT:1CT	±2%
Insertion Loss	-1.0dB max.	1MHz-100MHz
Return Loss	-18dB min.	1MHz-30MHz
	-16dB min.	30MHz-45MHz
	-14dB min.	45MHz-60MHz
	-12dB min.	60MHz-80MHz
Cross Talk	-35dB min.	1MHz-100MHz
Common Mode Rejection	-35dB min.	1MHz-100MHz

**Features**

- Surface Mount
- Low Profile Design
- AutoMDIX compatible
- Optional pin-outs
- Optimum performance
- Cost Effective
- Both RoHS compliant and lead-terminal parts available

Note1: Electrical Characteristics for individual part may vary; see specification sheet for actual values.

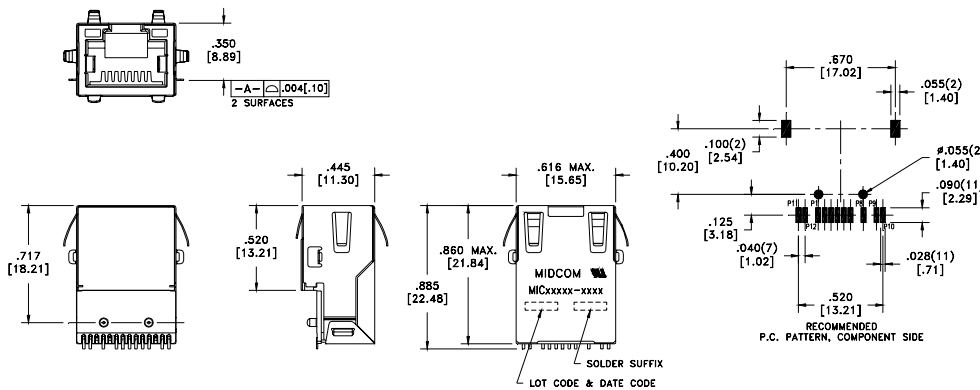

Part Number	LED (left-right)	Tab Direction	EMI Tabs	Dielectric Rating (1 Min.)	Operating Temp. Range
MIC24121-5301	Yellow-Green	Up	Yes	1500VAC	0°C to +70°C
MIC24121-5308	Yellow-Green	Up	Yes	2250VDC	-40°C to +85°C

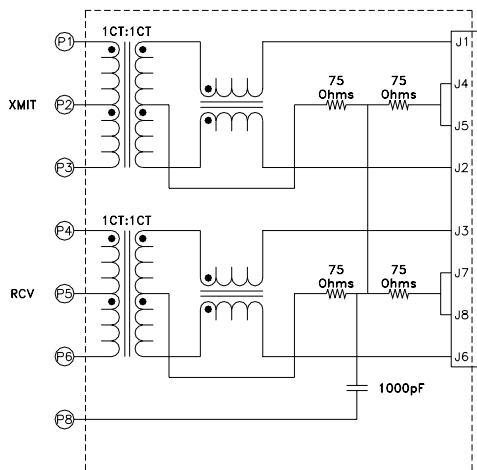

5/01/08 Details subject to change. Contact your Midcom sales representative for additional information. Dimensions: in/mm. All tolerances are ± .010/0,25 and electrical specifications are @ 25°C unless otherwise specified.

LANDatacom

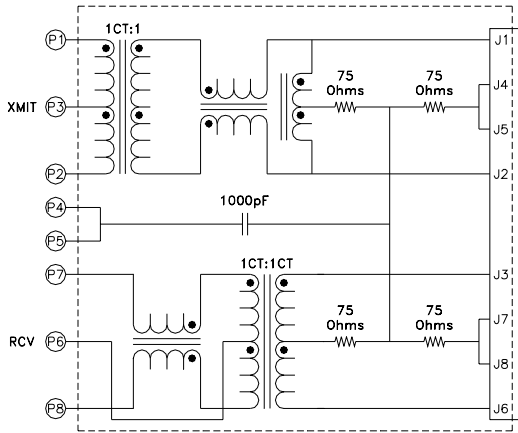

Features

- Surface Mount
- AutoMDIX compatible
- Operating Temperature 0°C to 70°C
- Optional pin-outs
- Industry standard connector footprint
- Optimum performance
- Cost Effective

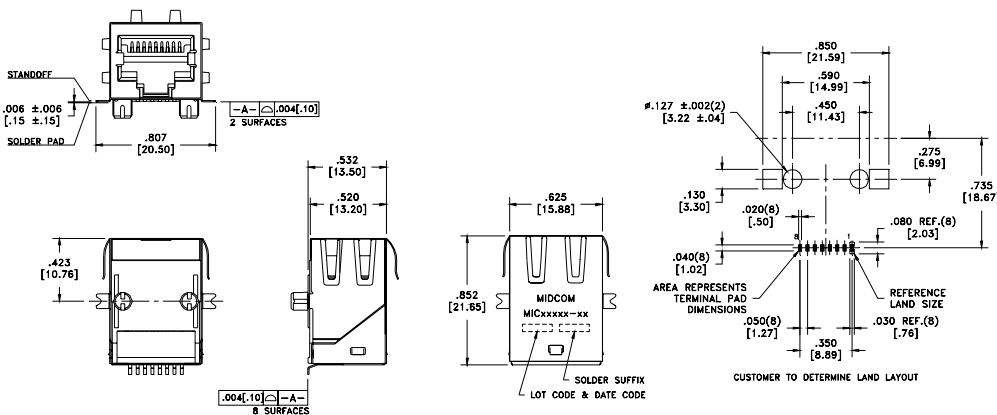

Part Number	LED (left-right)	Tab Direction	EMI Tabs
MIC25020-5110	None	Down	Yes

Electrical Characteristics

Inductance	350uH Min.	0.1Vrms, 100kHz, 8mADC
Dielectric Rating	1500VAC	for 1 minute
Turns Ratio	1CT:1CT	±2%
Insertion Loss	-1.0dB max.	1MHz-100MHz
Return Loss	-18dB min.	1MHz-30MHz
	-16dB min.	30MHz-45MHz
	-14dB min.	45MHz-60MHz
	-12dB min.	60MHz-80MHz
Cross Talk	-35dB min.	1MHz-100MHz
Common Mode Rejection	-35dB min.	1MHz-100MHz

Details subject to change. Contact your Midcom sales representative for additional information. Dimensions: in/mm. All tolerances are ± .010/0.25 and electrical specifications are @ 25°C unless otherwise specified.

**Integrated 10/100 Base-T RJ45  
Surface Mount MIC26 Series**



LANDatacom

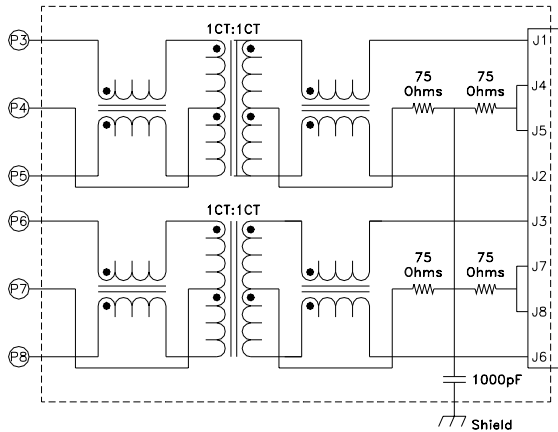

**Features**

- Surface Mount
- AutoMDIX compatible
- Operating Temperature 0°C to 70°C
- Optional pin-outs
- Industry standard connector footprint
- Optimum performance
- Cost Effective

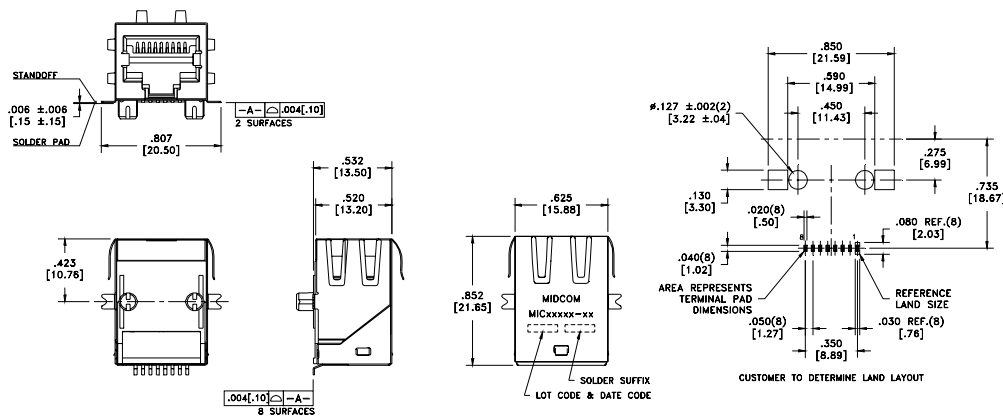

Part Number	LED (left-right)	Tab Direction	EMI Tabs
MIC26023-5134	Green-Yellow	Down	Yes

**Electrical Characteristics**

Inductance	350uH Min.	0.1Vrms, 100kHz, 8mA DC
Dielectric Rating	1500VAC	for 1 minute
Turns Ratio	1CT:1CT	±2%
Insertion Loss	-1.0dB max.	1MHz-100MHz
Return Loss	-18dB min.	1MHz-30MHz
	-16dB min.	30MHz-45MHz
	-14dB min.	45MHz-60MHz
	-12dB min.	60MHz-80MHz
Cross Talk	-35dB min.	1MHz-100MHz
Common Mode Rejection	-35dB min.	1MHz-100MHz

5/01/08 Details subject to change. Contact your Midcom sales representative for additional information. Dimensions: in/mm. All tolerances are ±.010/0.25 and electrical specifications are @ 25°C unless otherwise specified.

**Electrical Characteristics<sup>1</sup>**

Inductance	350uH Min.	0.1Vrms, 100kHz, 8mADC
Dielectric Rating	1500VAC	for 1 minute
Turns Ratio	1CT:1CT	±2%
Insertion Loss	-1.0dB max.	1MHz-100MHz
Return Loss	-18dB min.	1MHz-30MHz
	-16dB min.	30MHz-45MHz
	-14dB min.	45MHz-60MHz
	-12dB min.	60MHz-80MHz
Cross Talk	-35dB min.	1MHz-100MHz

Note1: Electrical Characteristics for individual part may vary; see specification sheet for actual values.

**Features**

- Through hole
- Single or dual integrated USB connectors
- Optional PoE compatible designs
- Operating temperature 0°C to +70°C
- Optional pin-outs and LEDs
- Industry standard footprint
- Optimum performance
- Cost effective
- Both RoHS compliant and lead-terminal parts available

Part Number	LED (left-right)	Tab Direction	USB Connectors	EMI Tabs	Mechanical	Schematic
MIC25U13-5115	Green-Yellow	Up	2	No	1	1
MIC24U13-5115	Green-Yellow	Up	2	No	1	3
MIC24U1C-6131	Green/Orange-Yellow	Up	1	Yes	2	2

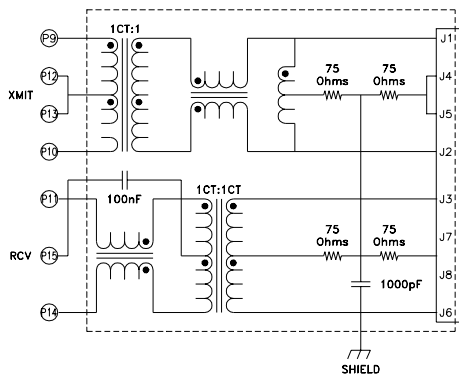

**Schematic 1**

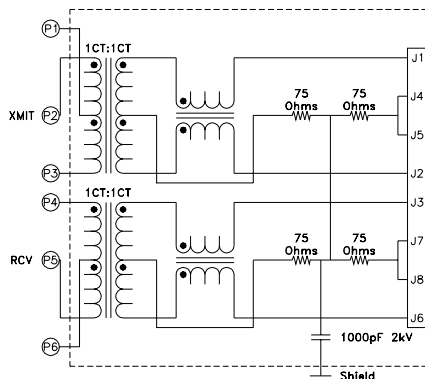

**Schematic 2**

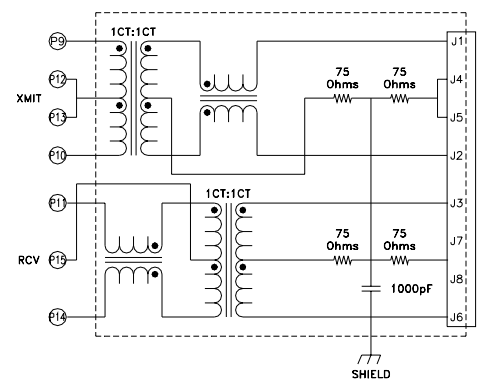

**Schematic 3**

Details subject to change. Contact your Midcom sales representative for additional information. Dimensions: in/mm. All tolerances are ± .010/0.25 and electrical specifications are @ 25°C unless otherwise specified.



### M1 - Dual USB

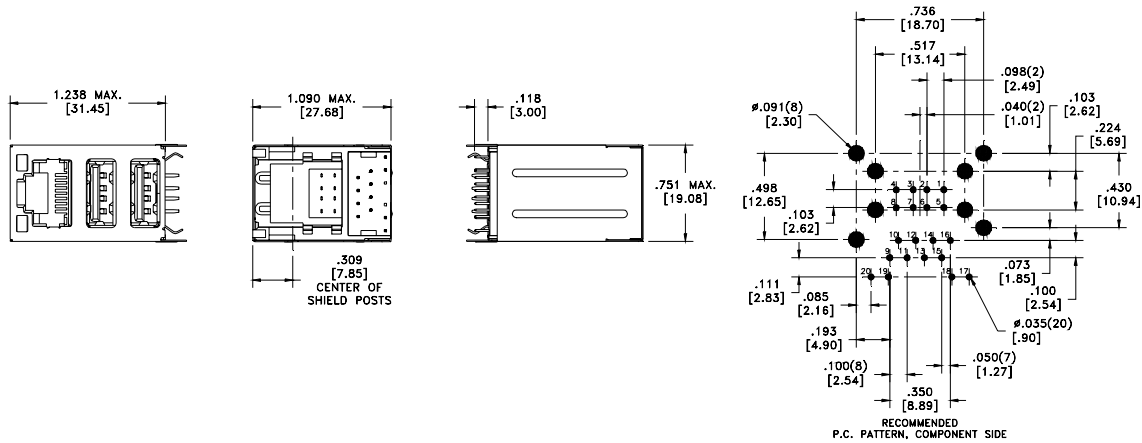

### M2 - Single USB

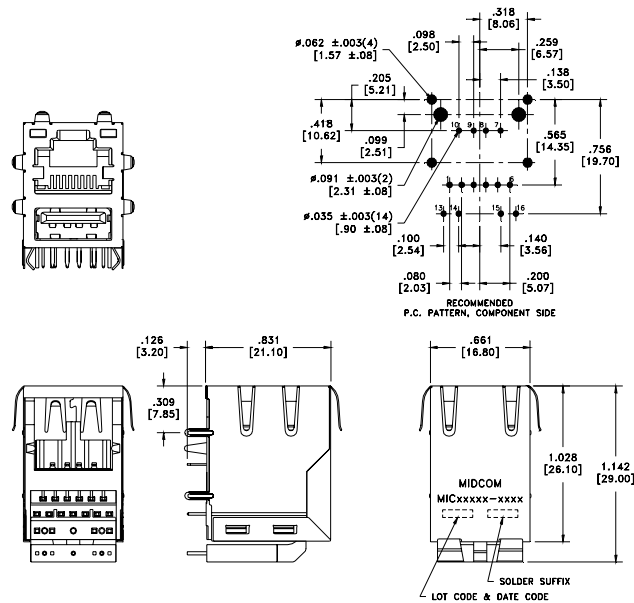

5/01/08 Details subject to change. Contact your Midcom sales representative for additional information. Dimensions: in/mm. All tolerances are ± .010/0,25 and electrical specifications are @ 25°C unless otherwise specified.

## Integrated Gigabit RJ45

Midcom



LANDatacom

Typical Electrical Characteristics<sup>1</sup>

Inductance	350uH Min.	0.1Vrms, 100kHz, 8mADC
Dielectric Rating	1500VAC	for 1 minute
Turns Ratio	1:1	±2%
Insertion Loss	-1.0dB max.	1MHz-100MHz
Return Loss	-18dB min.	1MHz-30MHz
	-12dB min.	30MHz-80MHz
Cross Talk	-40dB typ.	1MHz-30MHz
	-35dB typ.	30MHz-60MHz
	-30dB typ.	60MHz-100MHz
Common Mode Rejection	-30dB typ.	1MHz-100MHz

Note1: Electrical Characteristics for individual part may vary; see specification sheet for actual values.

## Features

- Through Hole
- Optional PoE compatible designs
- Optional pin-outs and LEDs
- Industry standard connector footprint
- Optimum performance
- Cost Effective
- Both RoHS compliant and lead-terminal parts available

Part Number	LED (left-right)	Tab Direction	EMI Tabs	Temp Range	Mechanical	Schematic
MIC38010-5265	None-None	Down	Yes	0°C to +70°C	1	4
MIC38011-5265	Yellow-Green	Down	Yes	0°C to +70°C	1	4
7499111212	Green-Yellow	Down	Yes	0°C to +70°C	1	5
7499111213	Green-Yellow	Down	Yes	0°C to +70°C	3	7
MIC38013-0155	Green-Yellow	Down	Yes	0°C to +70°C	1	1
MIC3801J-5169	Green-Green	Down	Yes	0°C to +70°C	1	6
MIC3801D-5166	Green/Yellow-Green/Yellow	Down	Yes	0°C to +70°C	1	8
7499111443	Green/Yellow-Green/Yellow	Down	Yes	0°C to +70°C	1	10
7499111440	Green/Yellow-Green/Yellow	Down	Yes	-40°C to +85°C	1	9
MIC3811B-0152	Green/Yellow-Green	Up	Yes	0°C to +70°C	2	2
MIC31112-0152	Green-Green	Up	Yes	0°C to +70°C	2	3
MIC3811A-0255	Green-Green/Yellow	Up	Yes	0°C to +70°C	5	6
7499110210	Green-Yellow	Down	No	0°C to +70°C	4	6

Details subject to change. Contact your Midcom sales representative for additional information. Dimensions: in/mm. All tolerances are ± .010/0.25 and electrical specifications are @ 25°C unless otherwise specified.

5/01/08

# Integrated Gigabit RJ45



LANDatacom

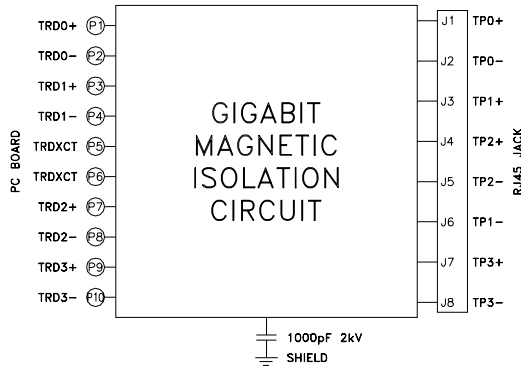

Schematic 1

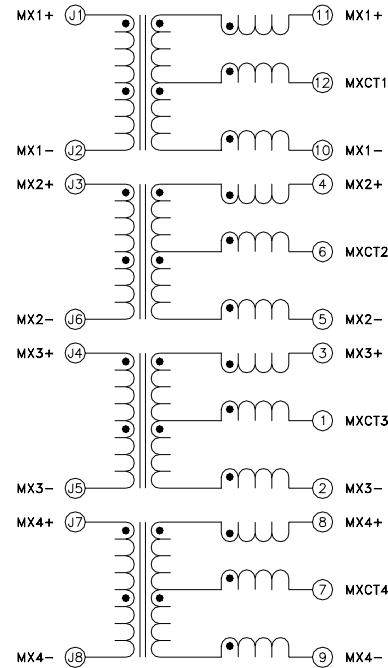

Schematic 2

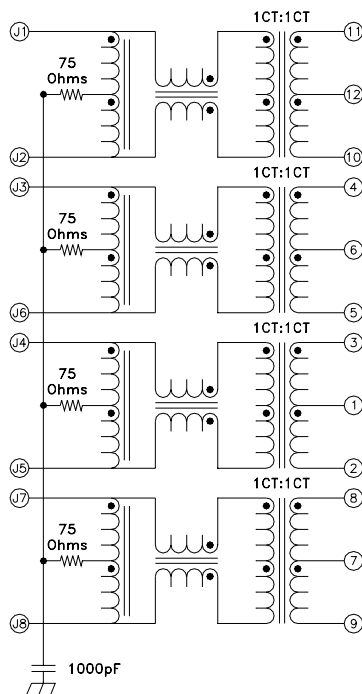

Schematic 3

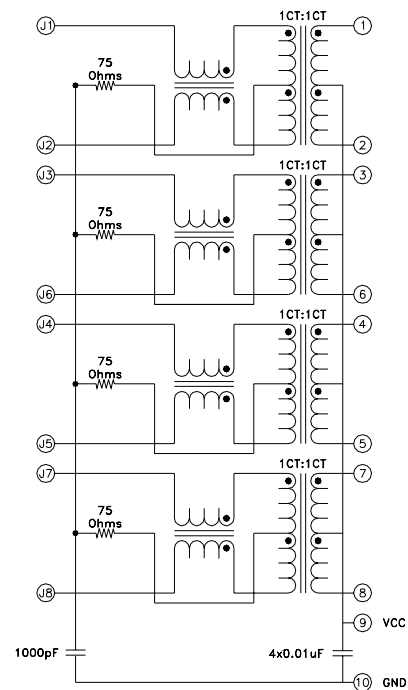

Schematic 4

5/01/08 Details subject to change. Contact your Midcom sales representative for additional information. Dimensions: in/mm. All tolerances are ±.010/0,25 and electrical specifications are @ 25°C unless otherwise specified.

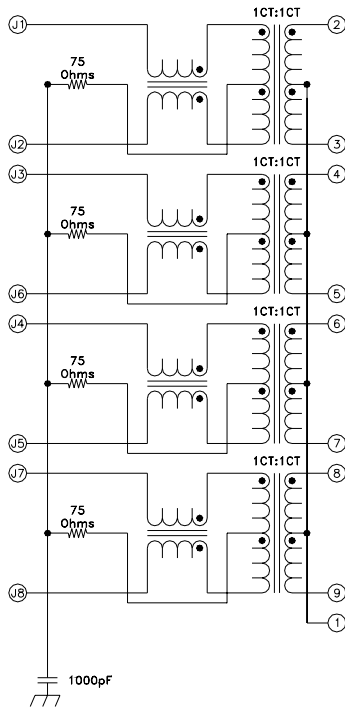

**Schematic 5**

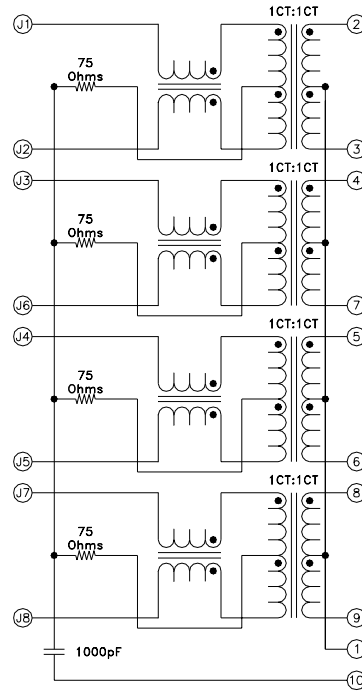

**Schematic 6**

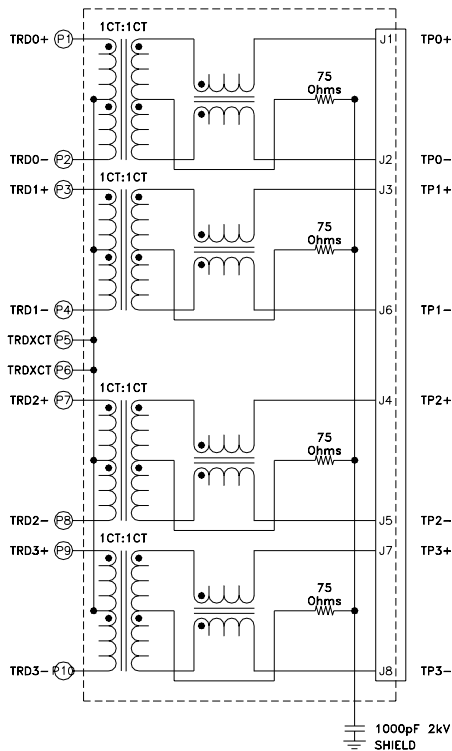

**Schematic 7**

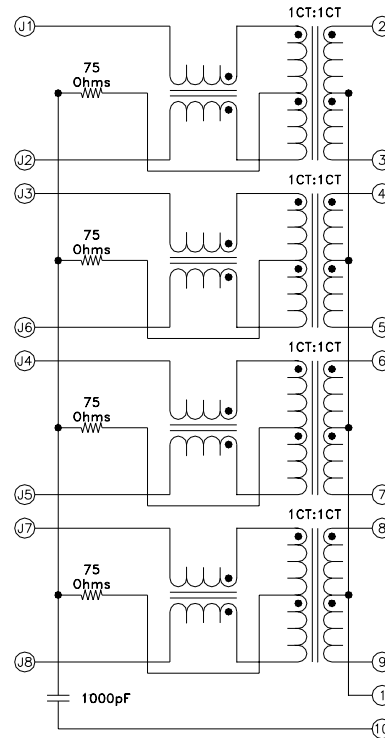

**Schematic 8**

Details subject to change. Contact your Midcom sales representative for additional information. Dimensions: in/mm. All tolerances are ± .010/0.25 and electrical specifications are @ 25°C unless otherwise specified.

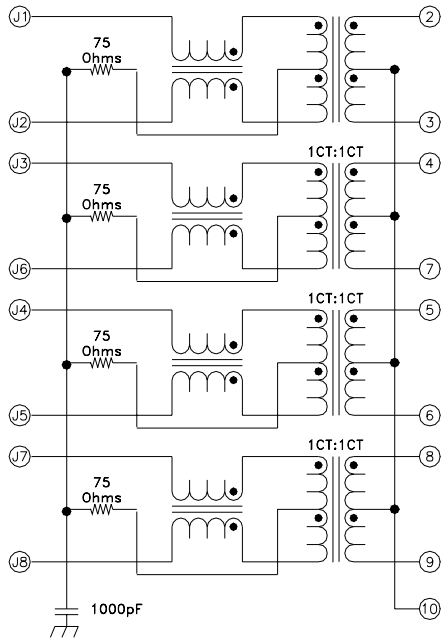

Schematic 9

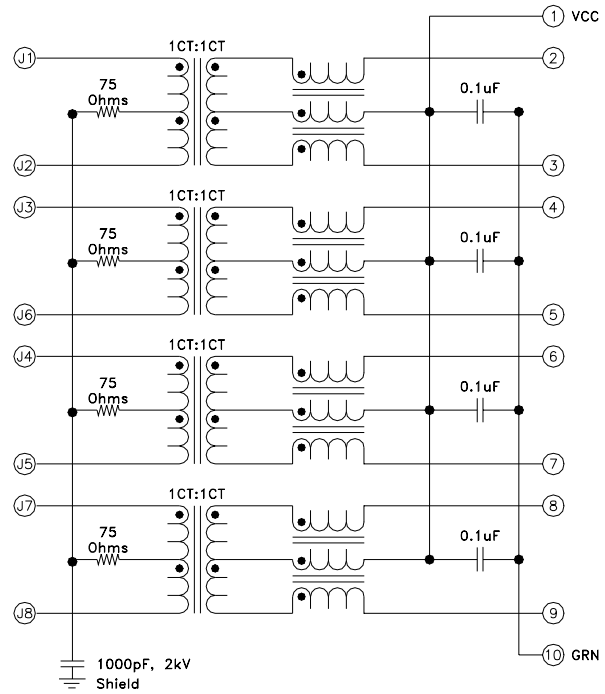

Schematic 10

LANDatacom

**M1 - Tab Down with EMI Tabs**

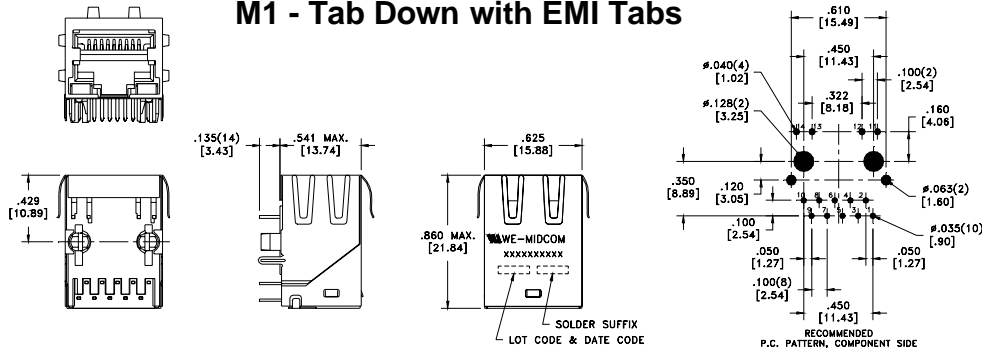

**M2 - Tab Up with EMI Tabs**

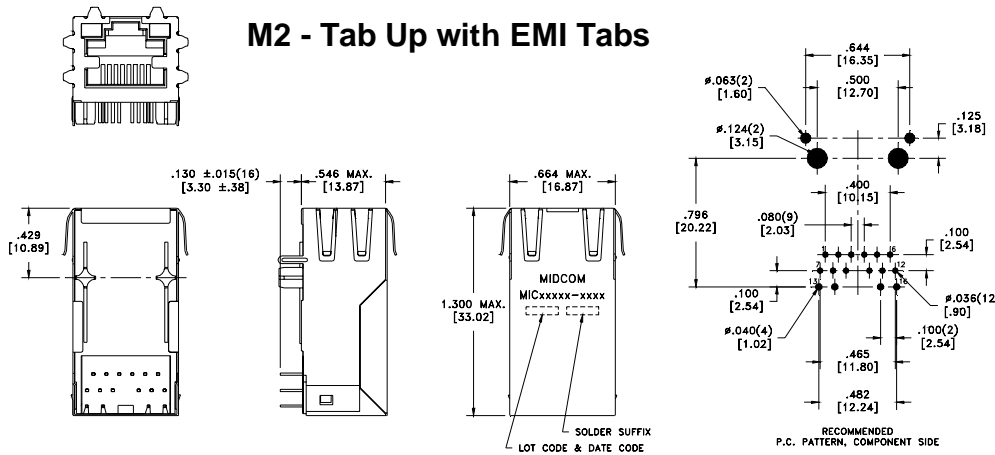

**M3 - Tab Down with EMI Tabs**

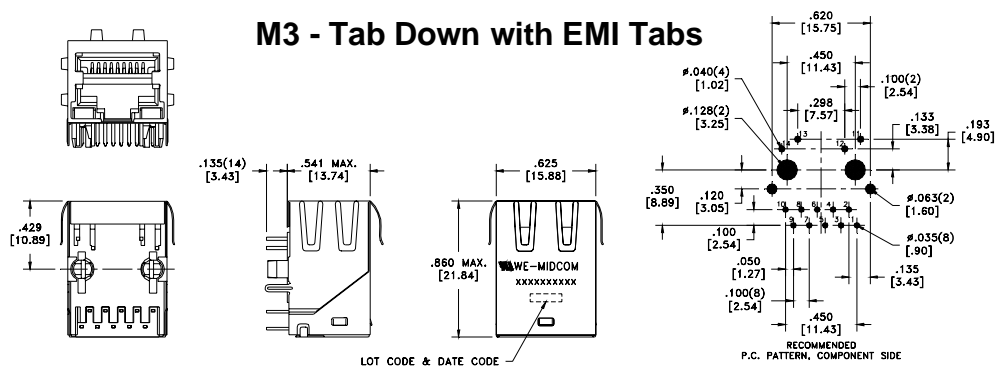

**M4 - Tab Down without EMI**

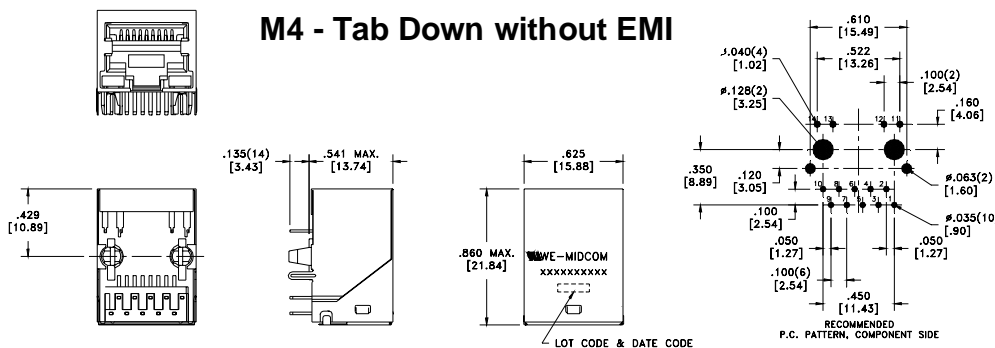

Details subject to change. Contact your Midcom sales representative for additional information. Dimensions: in/mm. All tolerances are ± .010/0.25 and electrical specifications are @ 25°C unless otherwise specified.

### M5 - Tab Up with EMI Tabs

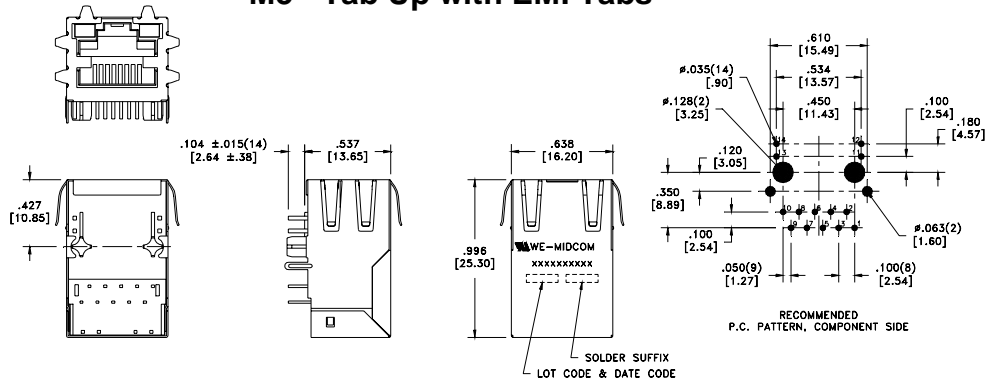



Integrated Gigabit  
Vertical RJ45

LANDatacom

**Typical Electrical Characteristics<sup>1</sup>**

Inductance	350uH Min.	0.1Vrms, 100kHz, 8mADC
Dielectric Rating	1500VAC	for 1 minute
Turns Ratio	1:1	±2%
Insertion Loss	-1.0dB max.	1MHz-100MHz
Return Loss	-18dB min.	1MHz-40MHz
	-14dB min.	40MHz-60MHz
	-12dB min.	60MHz-80MHz
	-10dB min.	80MHz-100MHz
Cross Talk	-30dB typ.	1MHz-100MHz
Common Mode Rejection	-35dB typ.	1MHz-100MHz

Note1: Electrical Characteristics for individual part may vary; see specification sheet for actual values.

**Features**

- Vertical tab orientation
- Through hole
- Optional pin-outs and LEDs
- Optimum performance
- Cost effective
- RoHS compliant

Part Number	LED (left-right)	Temp Range	EMI Tabs	Schematic
MIC38611-5166	Yellow-Green	0°C to +70°C	No	1

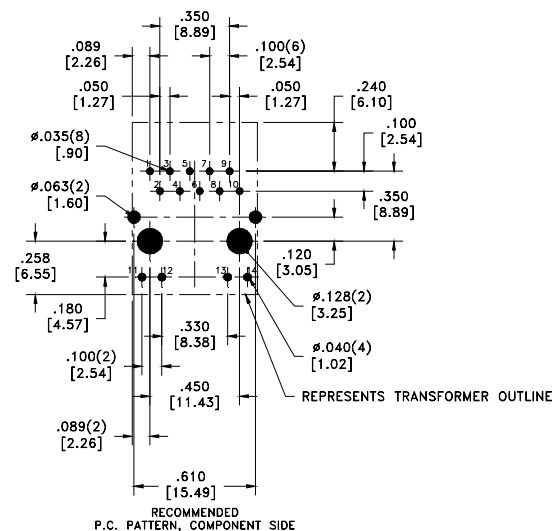
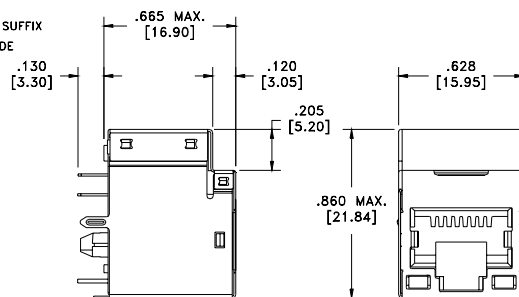
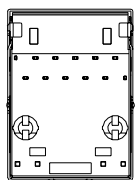
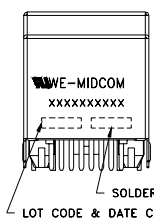

Details subject to change. Contact your Midcom sales representative for additional information. Dimensions: in/mm. All tolerances are ± .010/0.25 and electrical specifications are @ 25°C unless otherwise specified.



### Schematic 1

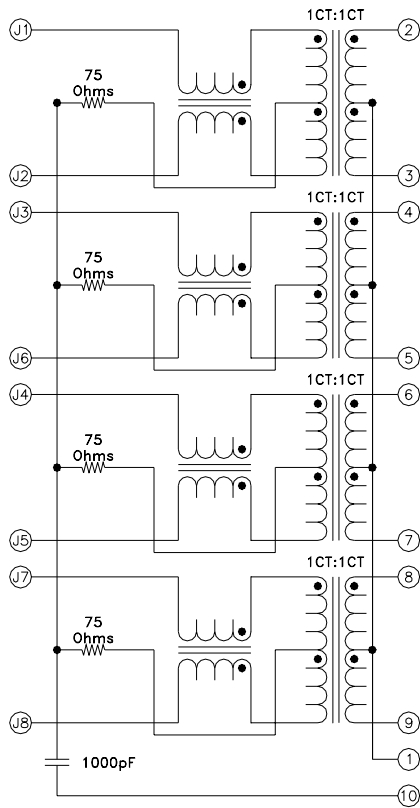

Typical Electrical Characteristics<sup>1</sup>

Inductance	350uH Min.	0.1Vrms, 100kHz, 8mADC
Dielectric Rating	1500VAC	for 1 minute
Turns Ratio	1:1	±2%
Insertion Loss	-1.0dB max.	1MHz-100MHz
Return Loss	-18dB min.	1MHz-30MHz
	-15dB min.	30MHz-60MHz
	-12dB min.	60MHz-80MHz
Cross Talk	-37dB typ.	1MHz-30MHz
	-32dB typ.	30MHz-60MHz
	-27dB typ.	60MHz-100MHz
Common Mode Rejection	-30dB typ.	1MHz-100MHz

Features

- Surface Mount
- Optional PoE compatible designs
- Optional pin-outs and LEDs
- Industry standard connector footprint
- Optimum performance
- Cost Effective
- RoHS compliant

Note1: Electrical Characteristics for individual part may vary; see specification sheet for actual values.

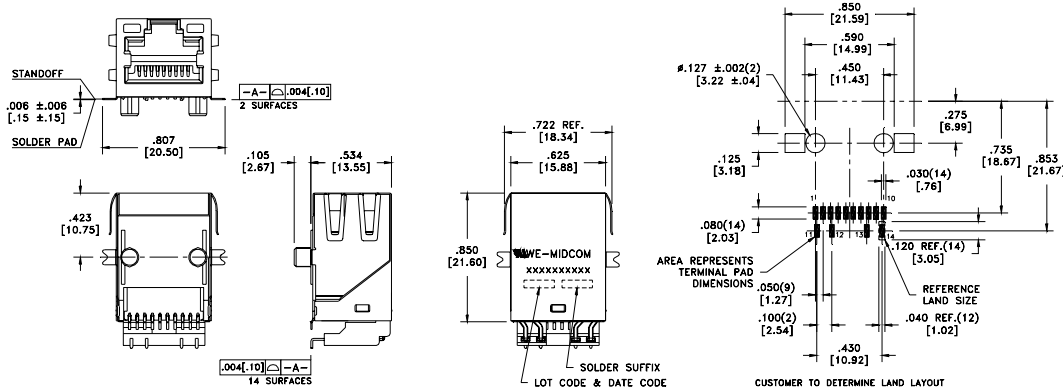

Part Number	LED (left-right)	Tab Direction	EMI Tabs	Temp Range
MIC38121-5154W	Yellow-Green	Up	Yes	0°C to +70°C

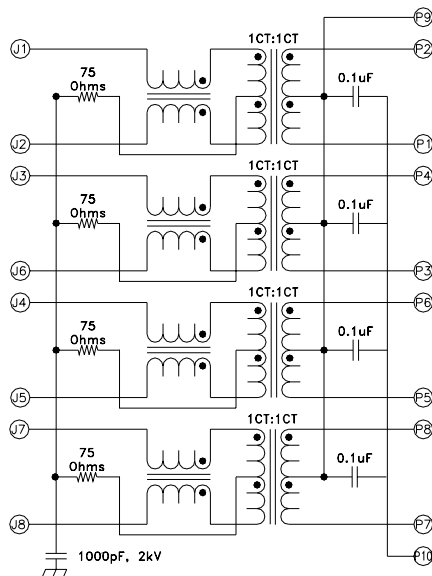

Details subject to change. Contact your Midcom sales representative for additional information. Dimensions: in/mm. All tolerances are ± .010/0.25 and electrical specifications are @ 25°C unless otherwise specified.

**Electrical Characteristics<sup>1</sup>**

Inductance	350uH Min.	0.1Vrms, 100kHz, 8mADC
Dielectric Rating	1500VAC	for 1 minute
Turns Ratio	1CT:1CT	±2%
Insertion Loss	-1.0dB max.	1MHz-100MHz
Return Loss	-18dB min.	1MHz-30MHz
	-16dB min.	30MHz-45MHz
	-14dB min.	45MHz-60MHz
	-12dB min.	60MHz-80MHz
Cross Talk	-27dB min.	1MHz-100MHz
Common Mode Rejection	-30dB min.	1MHz-100MHz

Note1: Electrical Characteristics for individual part may vary; see specification sheet for actual values.

**Features**

- Through hole
- Dual integrated USB connectors
- Operating temperature 0°C to +70°C
- Optional pin-outs and LEDs
- Optimum performance
- Cost effective
- Both RoHS compliant and lead-terminal parts available

Part Number	LED (left-right)	Tab Direction	EMI Tabs	Mechanical	Schematic
MIC31U1A-5153	Green-Green/Yellow	Up	No	1	1
7497111611	Green/Orange-Yellow	Up	Yes	2	2

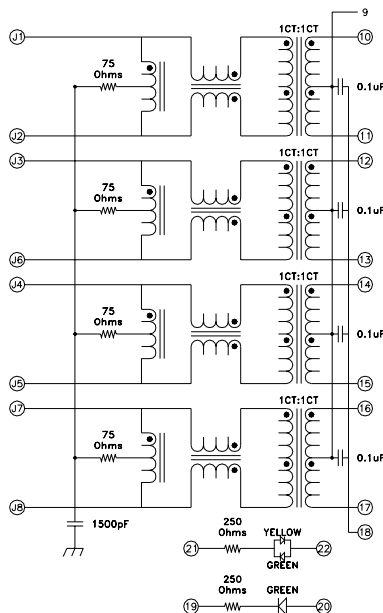

**Schematic 1**

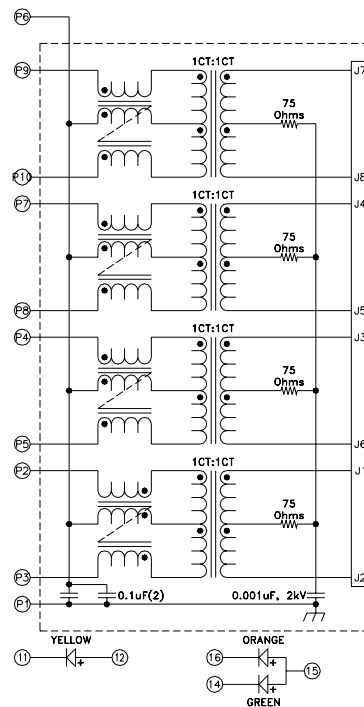

**Schematic 2**

### M1 - Dual USB without EMI Tabs

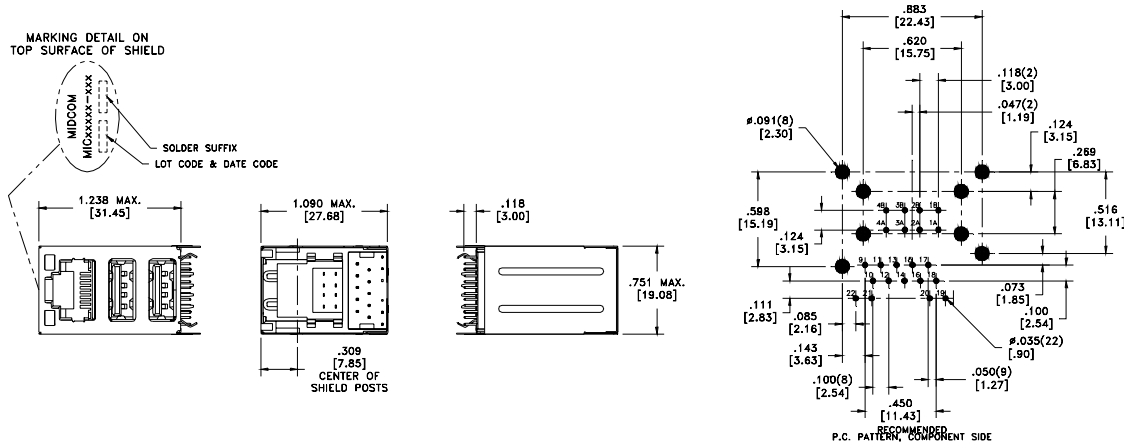

### M2 - Dual USB with EMI Tabs

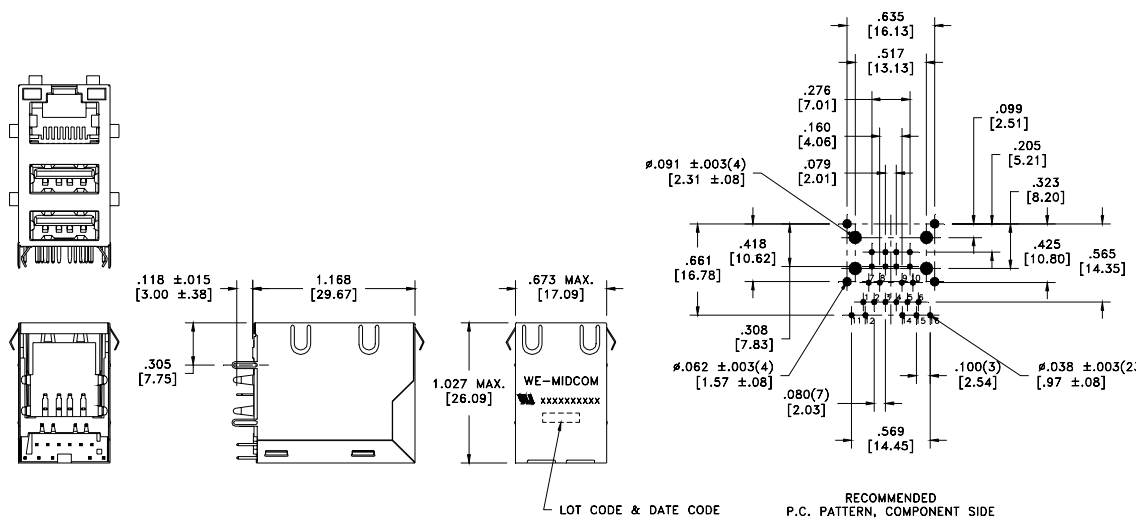

Details subject to change. Contact your Midcom sales representative for additional information. Dimensions: in/mm. All tolerances are ± .010/0.25 and electrical specifications are @ 25°C unless otherwise specified.

Integrated 1x2  
10/100 Base-T RJ45



LANDatacom

**Electrical Characteristics**

Inductance	350uH Min.	0.1Vrms, 100kHz, 8mADC
Dielectric Rating	1500VAC	for 1 minute
Turns Ratio	1CT:1CT	±2%
Insertion Loss	-1.0dB max.	1MHz-100MHz
Return Loss	-18dB min.	1MHz-30MHz
	-16dB min.	30MHz-45MHz
	-14dB min.	45MHz-60MHz
	-12dB min.	60MHz-80MHz
Cross Talk	-35dB min.	1MHz-100MHz
Common Mode Rejection	-35dB min.	1MHz-100MHz

Note 1: Electrical Characteristics for individual part may vary; see specification sheet for actual values.

**Features**

- Through hole
- AutoMDIX compatible
- Optional PoE compatible designs
- Operating Temperature 0°C to 70°C
- Optional pin-outs and LEDs
- Industry standard connector footprint
- Optimum performance
- Cost Effective
- Both RoHS compliant and lead-terminal parts available

Part Number	LED (left-right)	Tab Direction	EMI Tabs	Mechanical
MIC24810-0104	None	Down	Yes	2
MIC24811-0104	Yellow-Green	Down	Yes	1
7499021220	Green-Green	Down	Yes	1

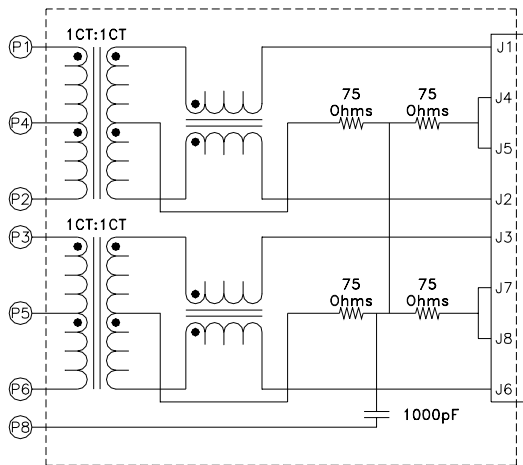

**Schematic 1**

5/01/08 Details subject to change. Contact your Midcom sales representative for additional information. Dimensions: in/mm. All tolerances are ± .010/0.25 and electrical specifications are @ 25°C unless otherwise specified.

Integrated 1x2  
10/100 Base-T RJ45



LANDatacom

### Mechanical 1

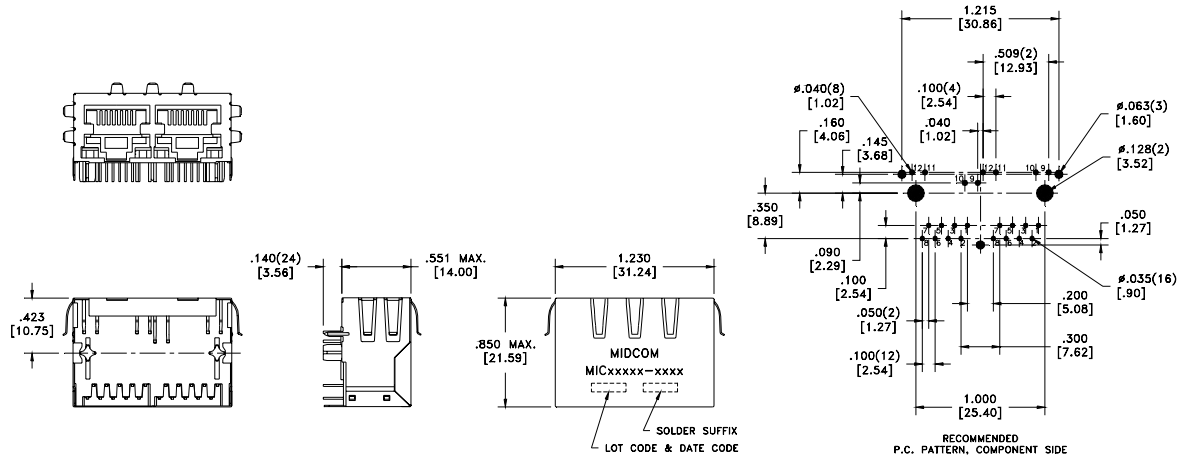

### Mechanical 2

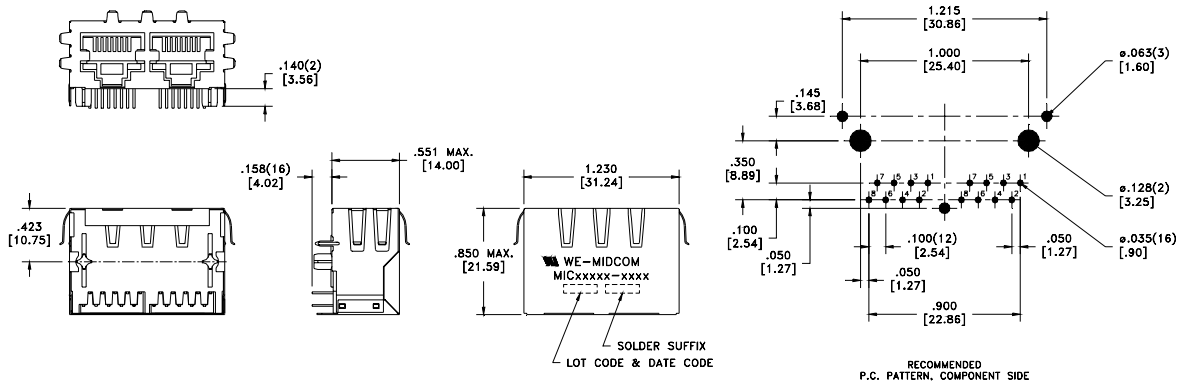

Details subject to change. Contact your Midcom sales representative for additional information. Dimensions: in/mm. All tolerances are ± .010/0.25 and electrical specifications are @ 25°C unless otherwise specified.

Integrated 1x4  
10/100 Base-T RJ45



LANDatacom

**Electrical Characteristics**

Inductance	350uH Min.	0.1Vrms, 100kHz, 8mADC
Dielectric Rating	1500VAC	for 1 minute
Turns Ratio	1CT:1CT	±2%
Insertion Loss	-1.0dB max.	1MHz-100MHz
Return Loss	-18dB min.	1MHz-30MHz
	-16dB min.	30MHz-45MHz
	-14dB min.	45MHz-60MHz
	-12dB min.	60MHz-80MHz
Cross Talk	-35dB min.	1MHz-100MHz
Common Mode Rejection	-35dB min.	1MHz-100MHz

**Features**

- Through hole
- AutoMDIX compatible
- Optional pin-outs and LEDs
- Industry standard connector footprint
- Optimum performance
- Cost Effective
- Both RoHS compliant and lead-terminal parts available

Note1: Electrical Characteristics for individual part may vary; see specification sheet for actual values.

Part Number	LED (left-right)	Tab Direction	EMI Tabs	Temp Range	Mechanical
MIC24510-0101	None	Down	No	0°C to +70°C	2
7499031002	None	Down	Yes	-40°C to +85°C	3
MIC24712-0108	Green-Green	Down	Yes	-40°C to +85°C	1
MIC24713-0101	Green-Yellow	Down	Yes	0°C to +70°C	1
7499031120	Yellow-Green	Down	Yes	-40°C to +85°C	1

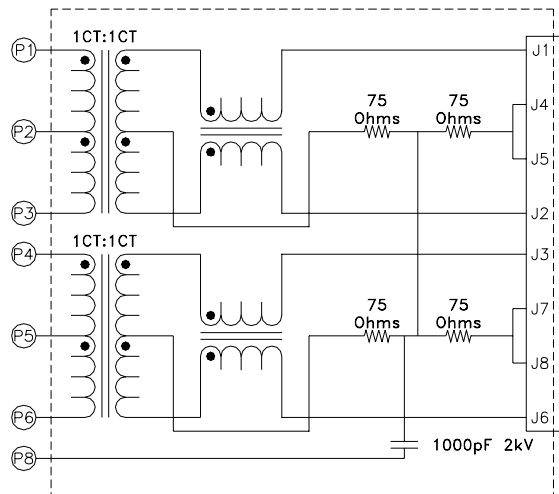

**Schematic 1**

5/01/08 Details subject to change. Contact your Midcom sales representative for additional information. Dimensions: in/mm. All tolerances are ± .010/0,25 and electrical specifications are @ 25°C unless otherwise specified.

Integrated 1x4  
10/100 Base-T RJ45



LANDatacom

### M1 With EMI Tabs

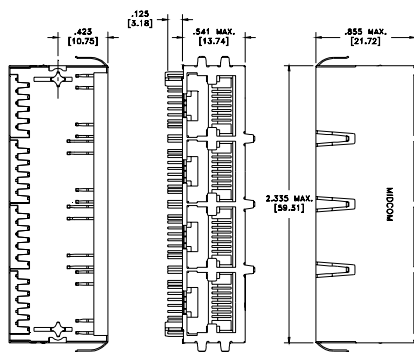

### M2 Without EMI Tabs

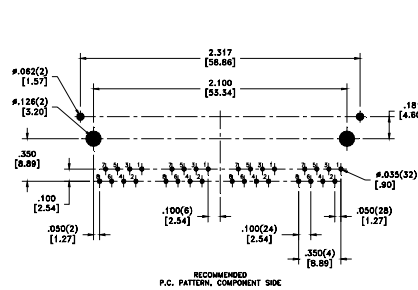
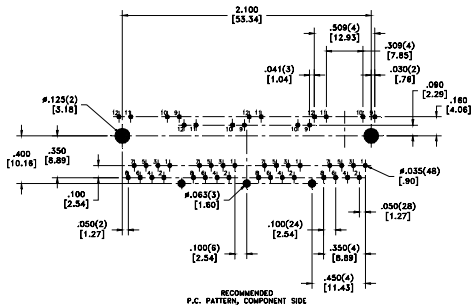
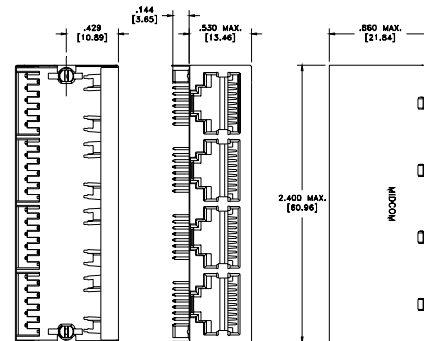

### M3 With EMI Tabs

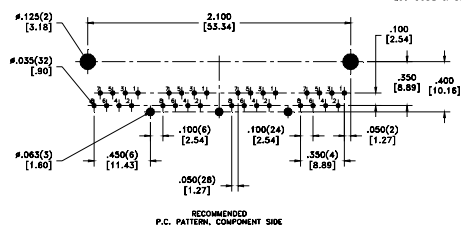
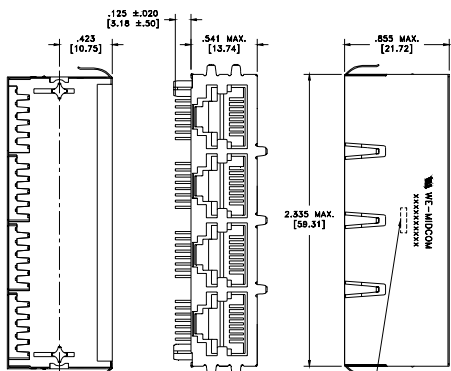

Data

Dimensions: in/mm. All tolerances are ± .010/0.25 and electrical specifications are @ 25°C unless otherwise specified.

5/01/08





# Integrated 1x4 Gigabit RJ45

LANDatacom

### Typical Electrical Characteristics

Inductance	350uH Min.	0.1Vrms, 100kHz, 8mADC
Dielectric Rating	1500VAC	for 1 minute
Turns Ratio	1:1	±2%
Insertion Loss	-1.1dB max.	1MHz-100MHz
Return Loss	-18dB min.	1MHz-40MHz
	-14dB min.	60MHz
	-12dB min.	80MHz
	-10dB min.	100 MHz
Crosstalk	-30dB typ.	1MHz-100MHz
Common Mode Rejection	-35dB min.	1MHz-100MHz

Note1: Electrical Characteristics for individual part may vary; see specification sheet for actual values.

### Features

- Through Hole
- Optional PoE compatible designs
- Operating Temperature 0°C to 70°C
- Optional pin-outs and LEDs
- Industry standard connector footprint
- Optimum performance
- Cost Effective
- Both RoHS compliant and lead-terminal parts available

Part Number	LED (left-right)	Tab Direction	EMI Tabs	Mechanical	Schematic
MIC38712-0151W	Green-Green	Down	Yes	1	1
MIC38710-5157W	None-None	Down	Yes	2	2

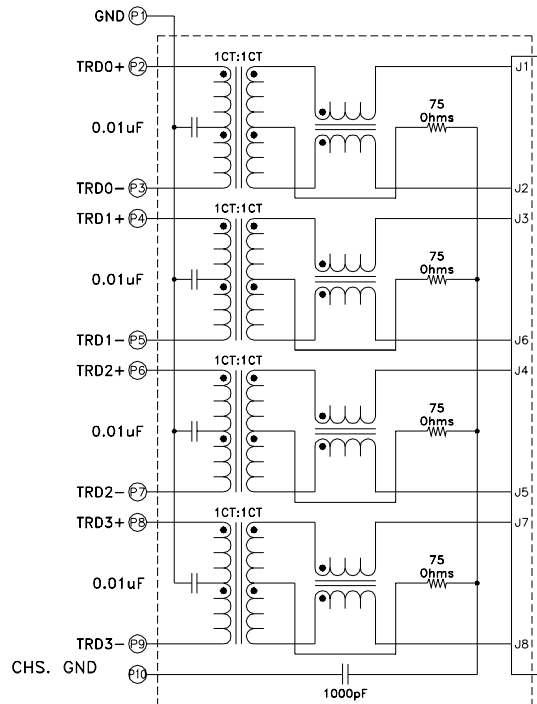

Schematic 1

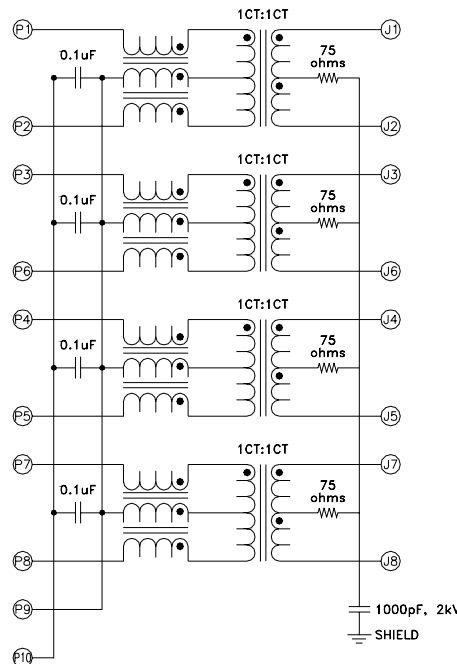

Schematic 2



**Integrated 1x4  
Gigabit RJ45**

LANDatacom

**Mechanical 1**

**Mechanical 2**

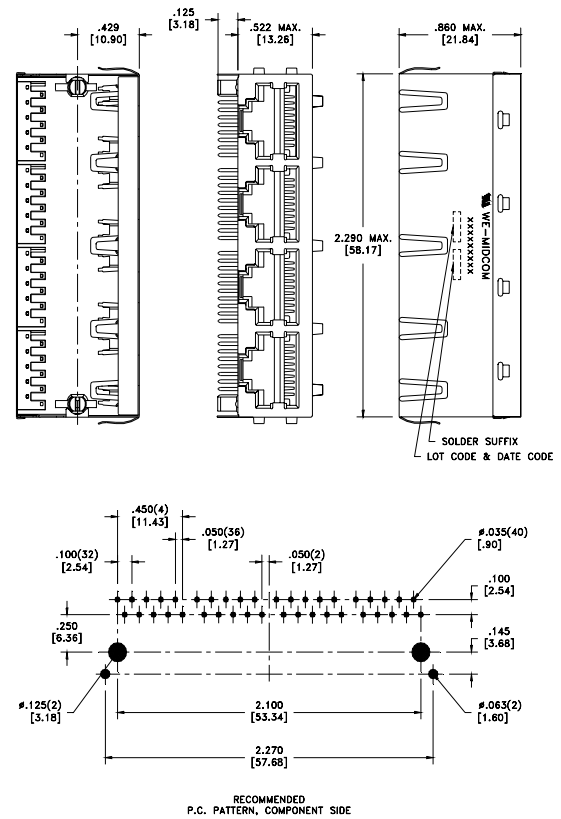
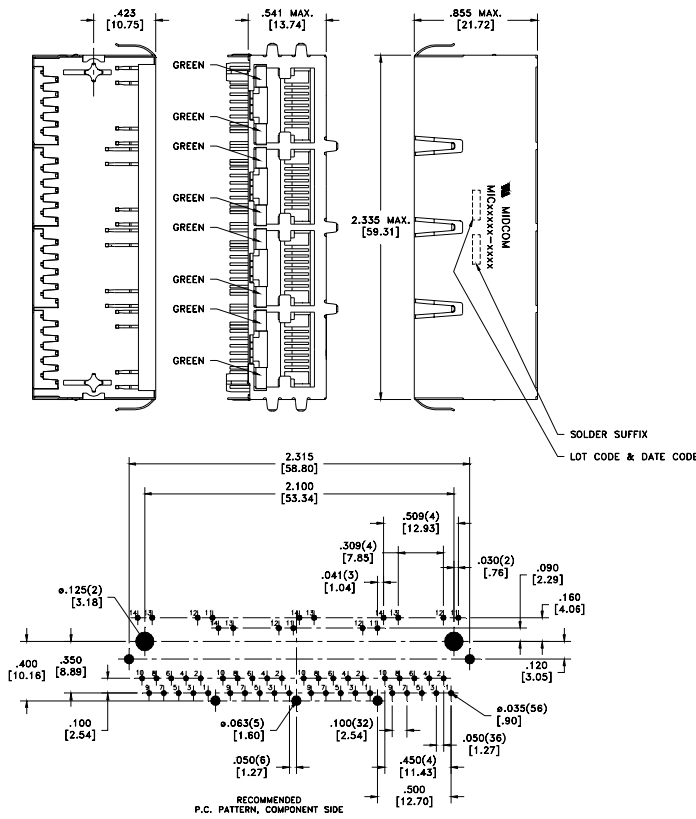

Details subject to change. Contact your Midcom sales representative for additional information. Dimensions: in/mm. All tolerances are ± .010/0.25 and electrical specifications are @ 25°C unless otherwise specified.

5/01/08

Integrated 2x6  
Gigabit RJ45



LANDatacom

**Typical Electrical Characteristics**

Inductance	350uH Min.	0.1Vrms, 100kHz, 8mADC
Dielectric Rating	2250VDC	for 1 minute
Turns Ratio	1:1	±2%
Insertion Loss	-1.0dB max.	1MHz-100MHz
Return Loss	-18dB min.	1MHz-40MHz
	-15dB min.	60MHz
	-12dB min.	80MHz
	-10dB min.	100 MHz
Crosstalk	-27dB min.	1MHz-100MHz
Common Mode Rejection	-30dB min.	1MHz-100MHz
	-15dB min.	100MHz-200MHz

**Features**

- Through Hole
- Optional PoE compatible designs
- Operating Temperature 0°C to 70°C
- Optional pin-outs and LEDs
- Industry standard connector footprint
- Optimum performance
- Cost Effective
- Both RoHS compliant and lead-terminal parts available

Part Number	LED (left-right)	EMI Tabs
MIC38D1E-5163W	Green-Yellow	Yes

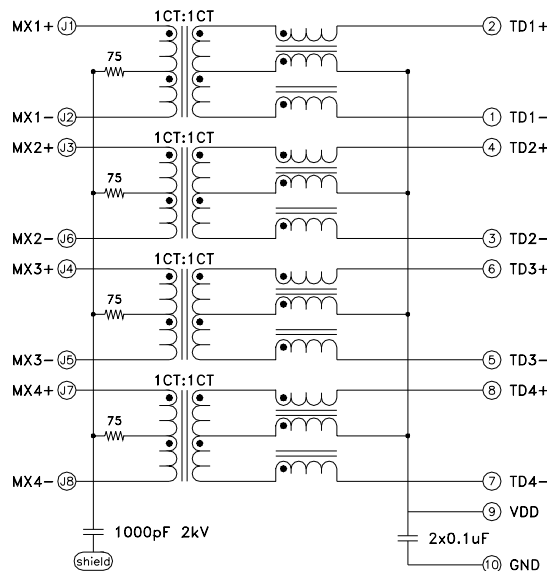

5/01/08 Details subject to change. Contact your Midcom sales representative for additional information. Dimensions: in/mm. All tolerances are ±.010/0.25 and electrical specifications are @ 25°C unless otherwise specified.

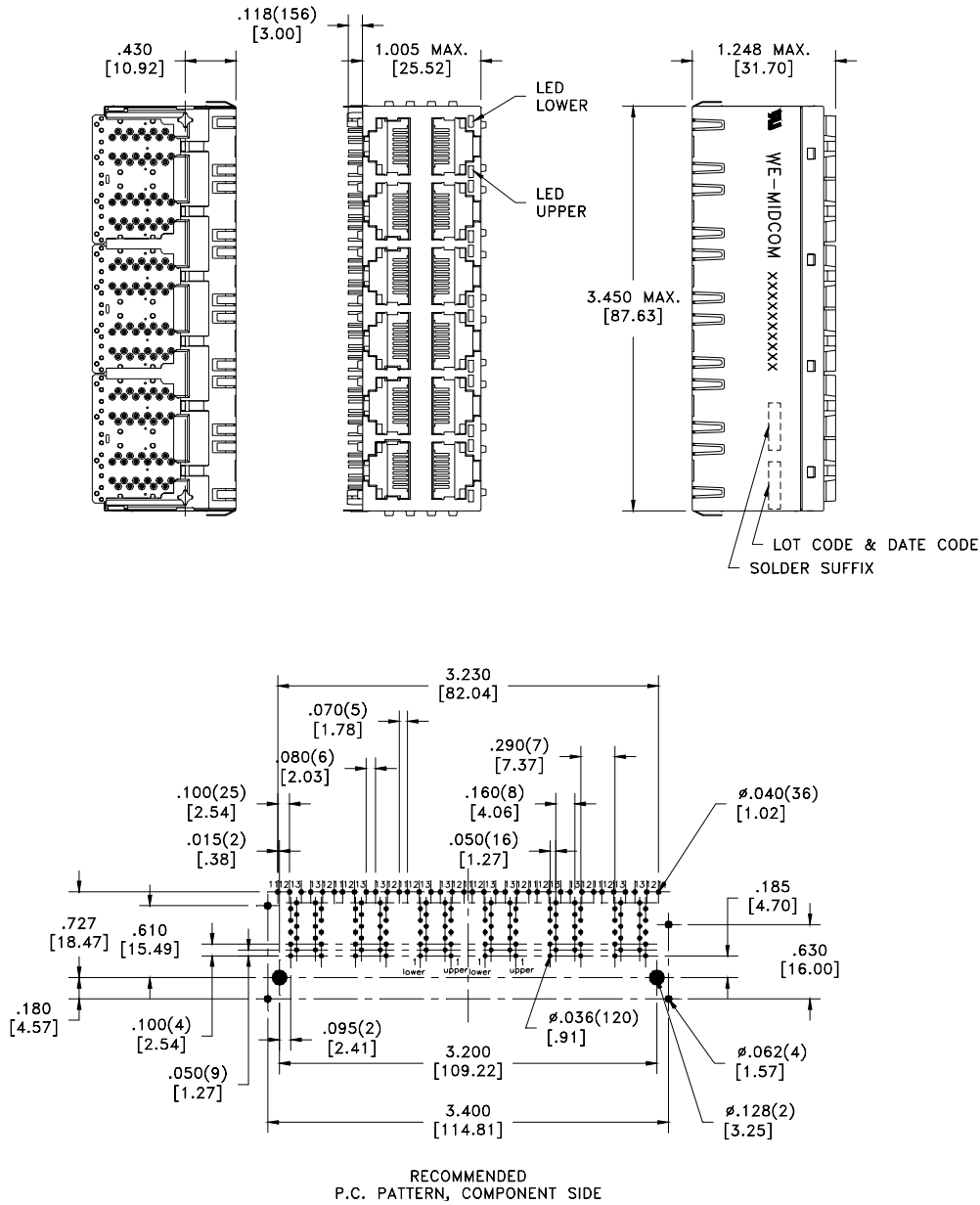

Details subject to change. Contact your Midcom sales representative for additional information. Dimensions: in/mm. All tolerances are  $\pm .010/0.25$  and electrical specifications are @ 25°C unless otherwise specified.



Integrated 2x8  
Gigabit RJ45

LANDatacom

**Typical Electrical Characteristics**

Inductance	350uH Min.	0.1Vrms, 100kHz, 8mADC
Dielectric Rating	2250VDC	for 1 minute
Turns Ratio	1:1	±2%
Insertion Loss	-1.0dB max.	1MHz-100MHz
Return Loss	-18dB min.	1MHz-40MHz
	-15dB min.	60MHz
	-12dB min.	80MHz
	-10dB min.	100 MHz
Crosstalk	-27dB min.	1MHz-100MHz
Common Mode Rejection	-30dB min.	1MHz-100MHz
	-15dB min.	100MHz-200MHz

**Features**

- Through Hole
- Optional PoE compatible designs
- Operating Temperature 0°C to 70°C
- Optional pin-outs and LEDs
- Industry standard connector footprint
- Optimum performance
- Cost Effective
- Both RoHS compliant and lead-terminal parts available

Part Number	LED (left-right)	EMI Tabs
MIC38E1F-5154W	Green/Orange-Green/Orange	Yes

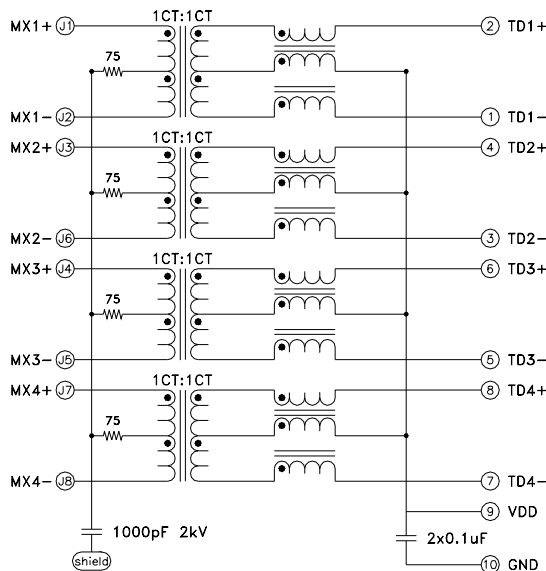

5/01/08 Details subject to change. Contact your Midcom sales representative for additional information. Dimensions: in/mm. All tolerances are ±.010/0.25 and electrical specifications are @ 25°C unless otherwise specified.



Integrated 2x8  
Gigabit RJ45

Midcom

LANDatacom

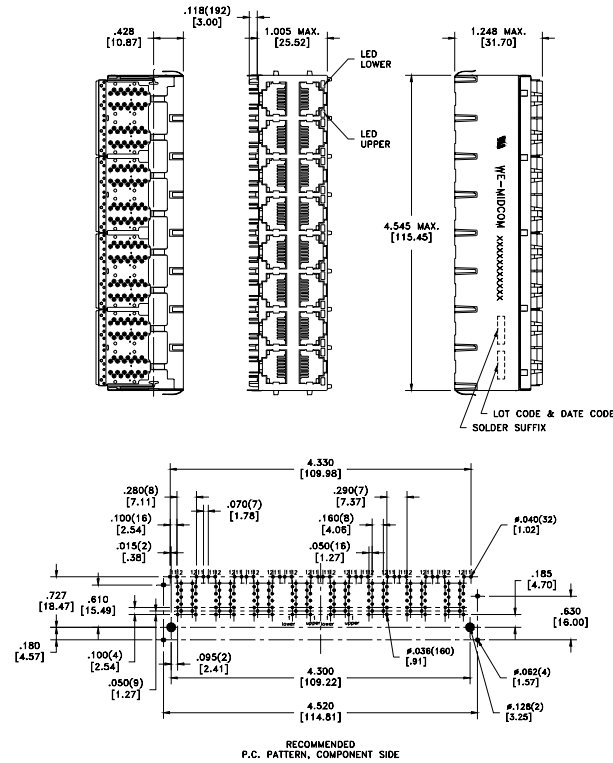

Details subject to change. Contact your Midcom sales representative for additional information. Dimensions: in/mm. All tolerances are ± .010/0.25 and electrical specifications are @ 25°C unless otherwise specified.

5/01/08

**Electrical Characteristics**

Inductance	350uH Min.	0.1Vrms, 100kHz, 8mADC
Dielectric Rating	1500VAC	for 1 minute
Turns Ratio	1CT:1CT	±2%
Insertion Loss	-1.0dB max.	1MHz-100MHz
Return Loss	-18dB min.	1MHz-30MHz
	-16dB min.	30MHz-45MHz
	-14dB min.	45MHz-60MHz
	-12dB min.	60MHz-80MHz
Cross Talk	-35dB min.	1MHz-100MHz
Common Mode Rejection	-35dB min.	1MHz-100MHz

Note1: Electrical Characteristics for individual part may vary; see specification sheet for actual values.

**Features**

- Through hole
- AutoMDIX compatible
- Optional PoE compatible designs
- Optional pin-outs and LEDs
- Industry standard connector footprint
- Optimum performance
- Cost Effective
- RoHS compliant

Part Number	LED (left-right)	Tab Direction	EMI Tabs	Temp Range
MIC24910-0101	None	Down	No	0°C to +70°C

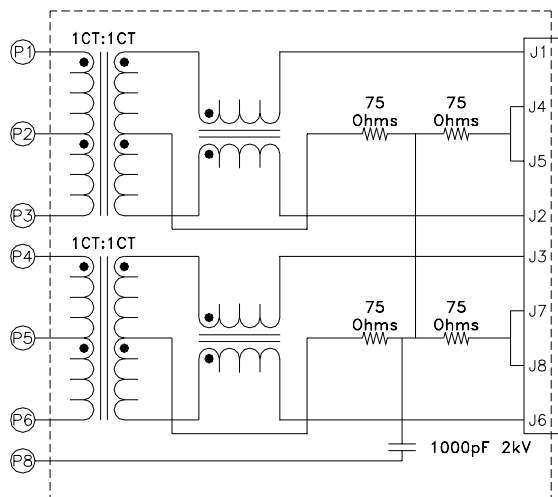

**Schematic 1**

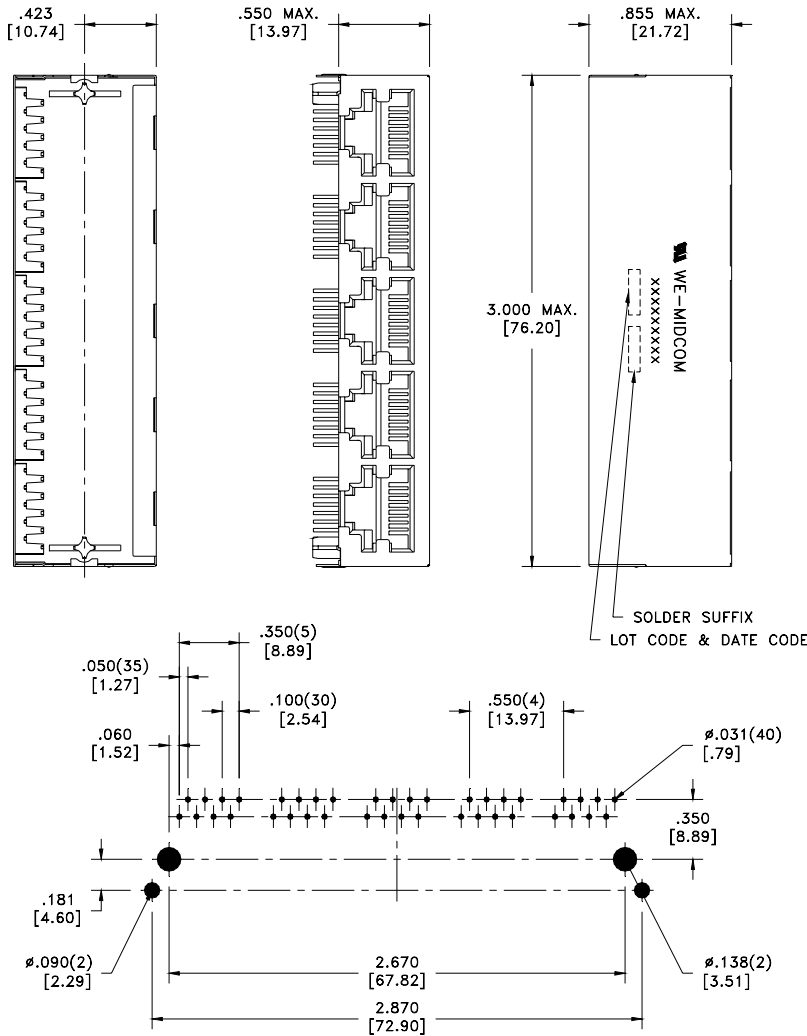

SOLDER SUFFIX  
LOT CODE & DATE CODE

RECOMMENDED  
P.C. PATTERN, COMPONENT SIDE

**Mechanical 1**



Integrated 2x1  
10/100 Base-T RJ45



LANDatacom

**Electrical Characteristics**

Inductance	350uH Min.	0.1Vrms, 100kHz, 8mADC
Dielectric Rating	1500VAC	for 1 minute
Turns Ratio	1CT:1CT	±2%
Insertion Loss	-1.0dB max.	1MHz-100MHz
Return Loss	-18dB min.	1MHz-30MHz
	-16dB min.	30MHz-45MHz
	-14dB min.	45MHz-60MHz
	-12dB min.	60MHz-80MHz
Cross Talk	-33dB min.	1MHz-100MHz
Common Mode Rejection	-35dB min.	1MHz-100MHz

**Features**

- Through hole
- AutoMDIX compatible
- Optional PoE compatible designs
- Operating Temperature 0°C to 70°C
- Optional pin-outs and LEDs
- Industry standard connector footprint
- Optimum performance
- Cost Effective
- RoHS compliant

Note1: Electrical Characteristics for individual part may vary; see specification sheet for actual values.

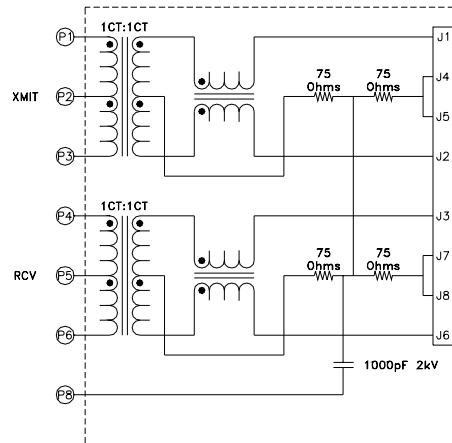

Part Number	LED (left-right)	EMI Tabs
MIC24A10-0101	None	Yes

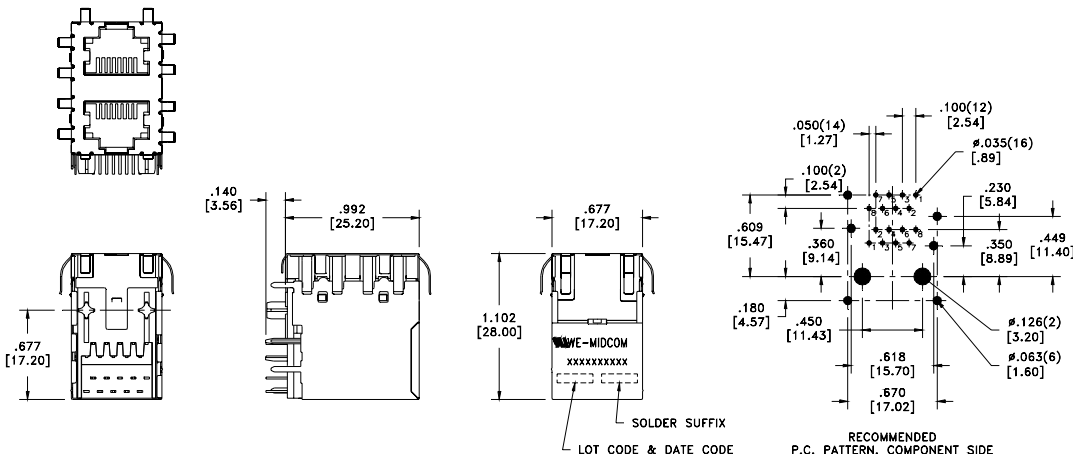

5/01/08 Details subject to change. Contact your Midcom sales representative for additional information. Dimensions: in/mm. All tolerances are ± .010/0,25 and electrical specifications are @ 25°C unless otherwise specified.

Würth Electronics Midcom, Inc. USA  
121 Airport Drive - PO Box 1330  
Watertown, SD 57201  
T: 605.886.4385 ~ F: 605.886.4486  
www.we-online.com ~ email:sales@midcom-inc.com

**Electrical Characteristics**

Inductance	350uH Min.	0.1Vrms, 100kHz, 8mA DC
Dielectric Rating	1500VAC	for 1 minute
Turns Ratio	1CT:1CT	±2%
Insertion Loss	-1.0dB typ.	1MHz-100MHz
Return Loss	-20dB typ.	1MHz-10MHz
	-16dB typ.	10MHz-30MHz
	-14dB typ.	30MHz-60MHz
	-12dB typ.	60MHz-80MHz
Cross Talk	-30dB typ.	1MHz-100MHz
Common Mode Rejection	-30dB typ.	1MHz-50MHz
	-20dB typ.	50MHz-150MHz

**Features**

- Through hole
- AutoMDIX compatible
- Optional PoE compatible designs
- Optional pin-outs and LEDs
- Industry standard connector footprint
- Optimum performance
- Cost Effective
- Operating Temperature 0°C to 70°C
- RoHS compliant

**Part Number LED (left-right) EMI Tabs**

MIC24C10-0101	None	Yes
---------------	------	-----

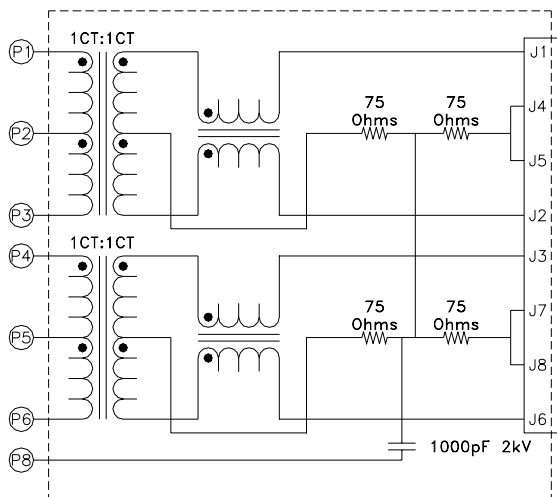

**Schematic 1**

Integrated 2x4  
10/100 Base-T RJ45



LANDatacom

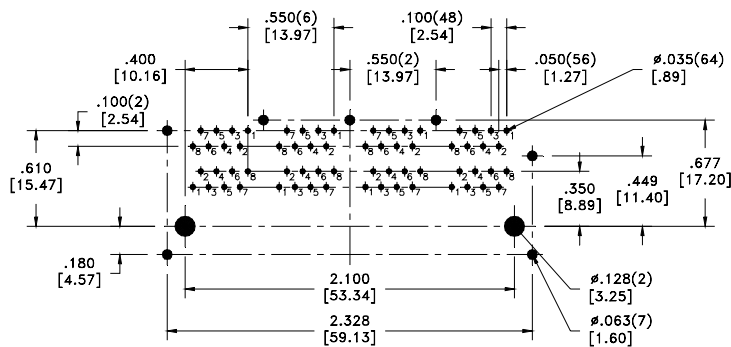
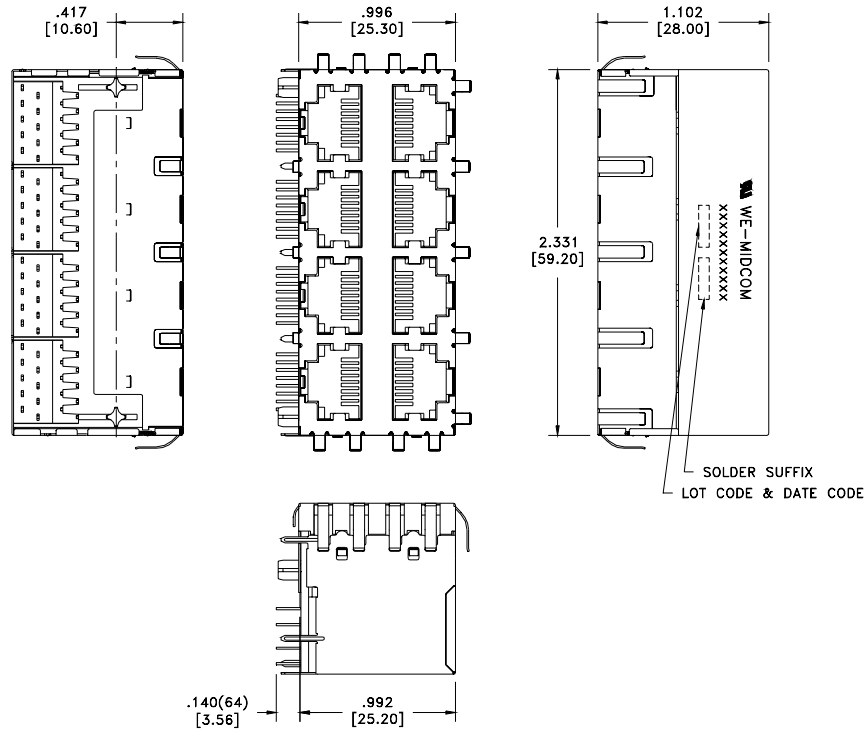

RECOMMENDED  
P.C. PATTERN, COMPONENT SIDE

5/01/08 Details subject to change. Contact your Midcom sales representative for additional information. Dimensions: in/mm. All tolerances are  $\pm .010/0,25$  and electrical specifications are @ 25°C unless otherwise specified.

## Integrated 2x6 10/100 Base-T RJ45

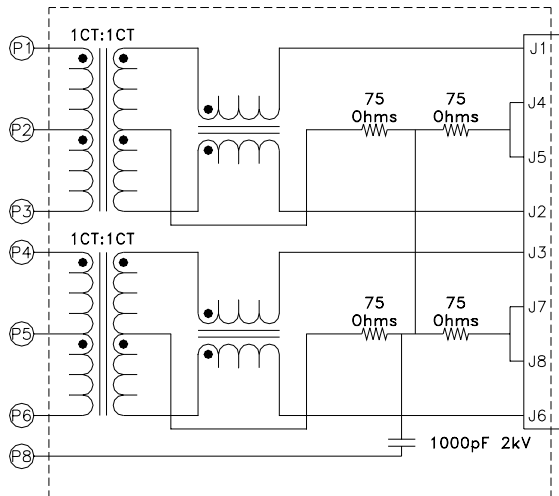

### Features

- Through hole
- AutoMDIX compatible
- Optional PoE compatible designs
- Operating Temperature 0°C to 70°C
- Optional pin-outs and LEDs
- Industry standard connector footprint
- Optimum performance
- Cost Effective
- Both RoHS compliant and lead-terminal parts available

Part Number	LED (left-right)	EMI Tabs
MIC24D10-0101	None	Yes

### Electrical Characteristics

Inductance	350uH Min.	0.1Vrms, 100kHz, 8mADC
Dielectric Rating	1500VAC	for 1 minute
Turns Ratio	1CT:1CT	±2%
Insertion Loss	-1.0dB typ.	1MHz-65MHz
Return Loss	-20dB min.	1MHz-10MHz
	-16dB min.	10MHz-30MHz
	-12dB min.	30MHz-60MHz
	-12dB min.	60MHz-80MHz
Cross Talk	-30dB min.	1MHz-100MHz
Common Mode Rejection	-30dB min.	1MHz-50MHz
	-20dB min.	50MHz-150MHz

## Integrated 2x6 10/100 Base-T RJ45 Mechanical and PCB

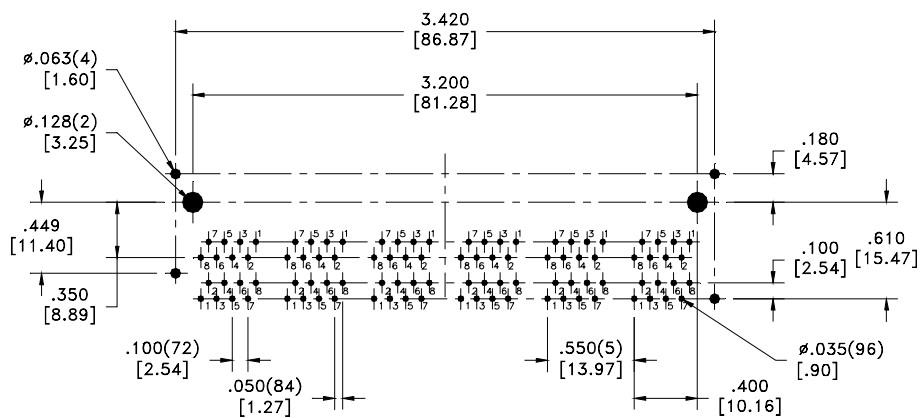
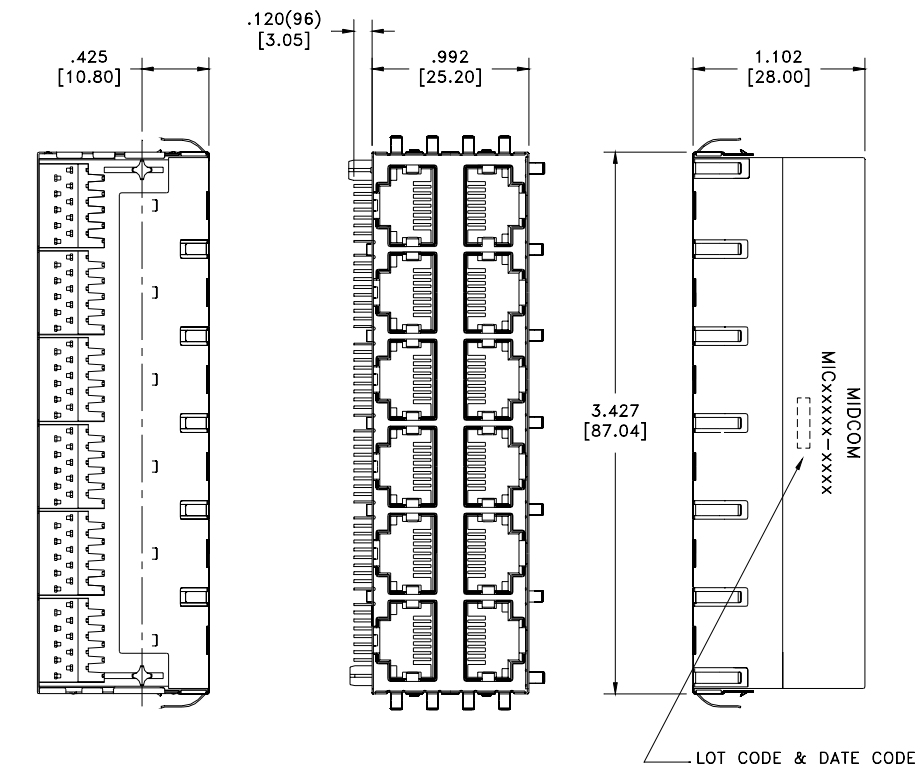

RECOMMENDED  
P.C. PATTERN, COMPONENT SIDE

5/01/08 Details subject to change. Contact your Midcom sales representative for additional information. Dimensions: in/mm. All tolerances are ± .010/0.25 and electrical specifications are @ 25°C unless otherwise specified.

# Discrete Single Port PoE 10/100 Base-T EDSO-G16

## Electrical Characteristics<sup>1</sup>

Inductance	350uH Min.	0.1Vrms, 100kHz, 8mADC
Dielectric Rating	1500VAC	for 1 minute
Insertion Loss	-1.2dB max.	1MHz-100MHz
Return Loss	-16dB min.	1MHz-30MHz
	-14dB min.	30MHz-40MHz
	-13dB min.	40MHz-50MHz
	-12dB min.	50MHz-80MHz
Cross Talk	-35dB min.	1MHz-100MHz
Diff. to Common Mode Rejection	-35dB min.	1MHz-100MHz

## Features

- PoE compatible
- Meets IEEE 802.3 standard
- Surface mount
- Optional pin-outs
- Industry standard connector footprint
- Optimum performance
- Cost Effective
- Both RoHS compliant and lead-terminal parts available

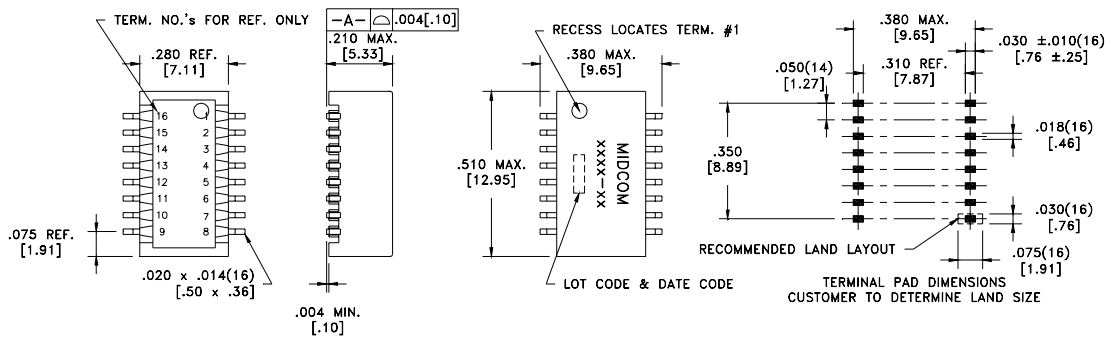

Part Number	Transmit Turns Ratio	AutoMDIX Compatible	Operating Temp. Range	Schematic
000-7333-30	1CT:1CT	Yes	-40°C to +85°C	1
000-7421-30	1CT:1CT	Yes	0°C to +70°C	2

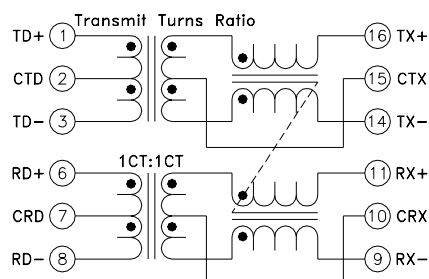

Schematic 1

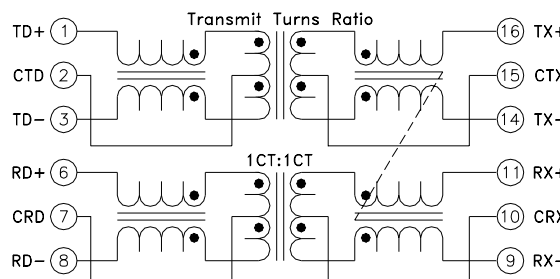

Schematic 2

Details subject to change. Contact your Midcom sales representative for additional information. Dimensions: in/mm. All tolerances are ± .010/0.25 and electrical specifications are @ 25°C unless otherwise specified.



Discrete Dual Port  
Gigabit PoE 24 Pin

LANDatacom

**Typical Common Electrical Characteristics<sup>1</sup>**

Inductance	350uH Min.	0.1Vrms, 100kHz, 8mADC
Dielectric Rating	1500VAC	for 1 minute
Insertion Loss	-1.0dB max.	1MHz-100MHz
Return Loss	-18dB min.	1MHz-40MHz
	-15dB min.	40MHz-60MHz
	-12dB min.	60MHz-80MHz
Cross Talk	-35dB min.	1MHz-100MHz
DCMR	-45dB min.	1MHz-60MHz
	-35dB min.	60MHz-100MHz

Note1: See specification sheet for actual electrical characteristics

**Features**

- Meets IEEE 802.3af standard
- Designed to handle 350mA for PoE applications
- Surface mount
- Optional pin-outs
- Industry standard footprint
- Optimum performance
- Cost Effective
- Both RoHS compliant and lead-terminal parts available

Part Number	Turns Ratio	AutoMDIX Compatible	Operating Temp. Range	Schematic	Mechanical
000-7338-30	1.41CT:1CT	Yes	0°C to +70°C	1	1
749013028	1CT:1CT	Yes	0°C to +70°C	2	2

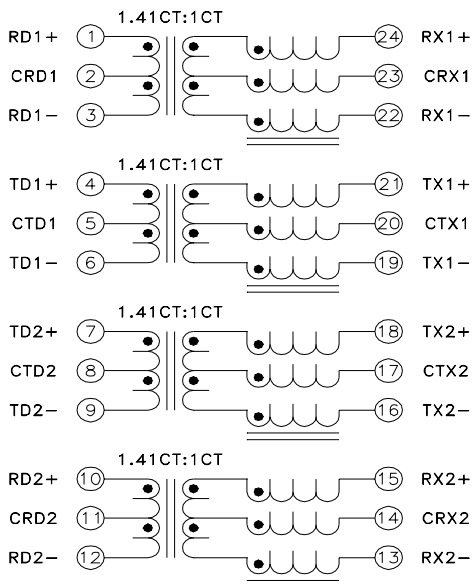

**Schematic 1**

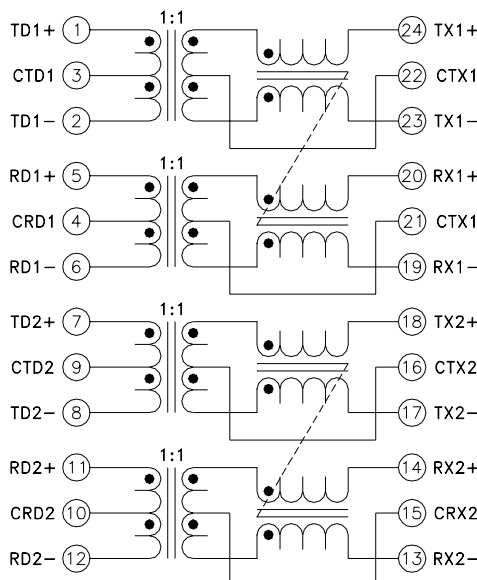

**Schematic 2**

5/01/08 Details subject to change. Contact your Midcom sales representative for additional information. Dimensions: in/mm. All tolerances are ± .010/0.25 and electrical specifications are @ 25°C unless otherwise specified.

### Mechanical 1

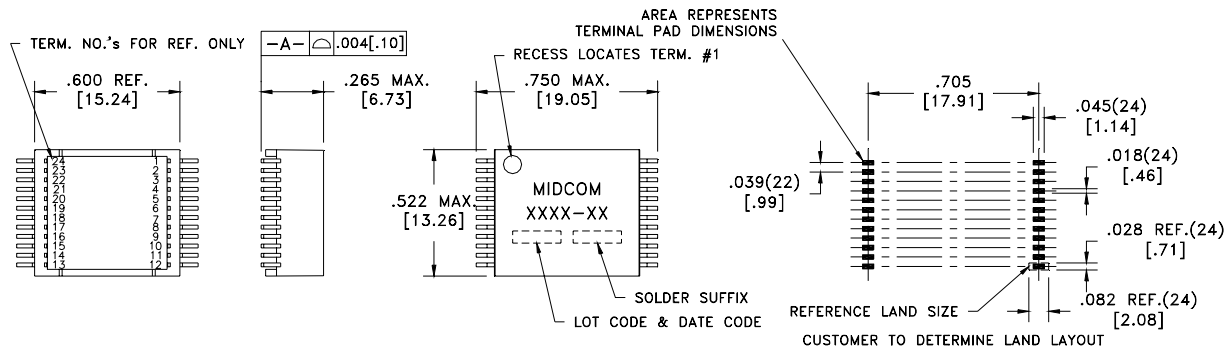

### Mechanical 2

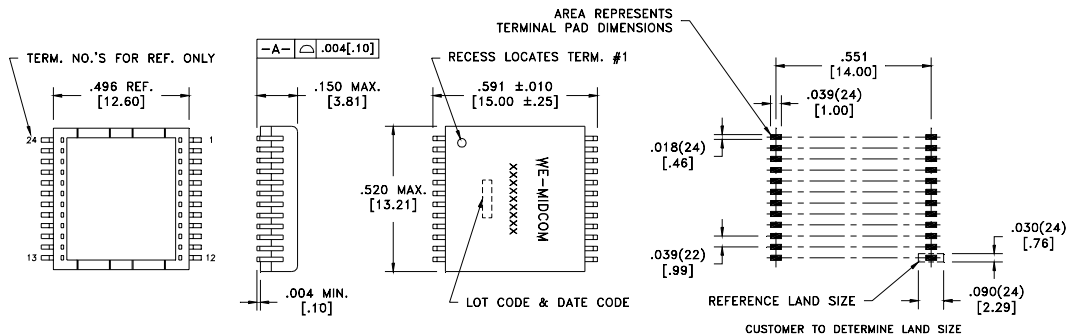

Details subject to change. Contact your Midcom sales representative for additional information. Dimensions: in/mm. All tolerances are ± .010/0.25 and electrical specifications are @ 25°C unless otherwise specified.



# Discrete Quad Port PoE 10/100 Base-T PDFP-G48

## Features

- Meets IEEE 802.3 standard
- Designed to handle 350mA for PoE applications
- Surface mount
- Optional pin-outs
- Industry standard connector footprint
- Optimum performance
- Cost Effective
- Both RoHS compliant and lead-terminal parts available

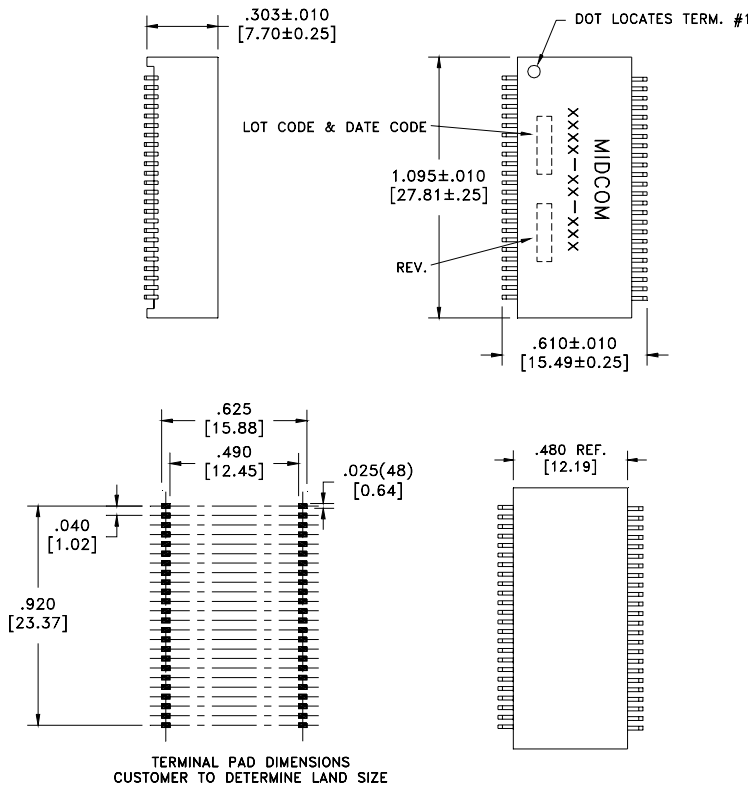

Part Number	Turns Ratio	AutoMDIX Compatible	Operating Temp. Range	Schematic
000-7415-30R	1CT:1CT	No	0°C to +70°C	1

### Typical Common Electrical Characteristics

Inductance	350uH Min.	0.1Vrms, 100kHz, 8mADC
Dielectric Rating	1500VAC	for 1 minute
Insertion Loss	-1.0dB max.	1MHz-100MHz
Return Loss	-16.0dB min.	1MHz-30MHz
	-14.4dB min.	40MHz
	-13.1dB min.	50MHz
	-10.0dB min.	60MHz-80MHz
Cross Talk	-35dB min.	100MHz
DCMR	-33dB min.	100MHz

## Discrete Quad Port PoE 10/100 Base-T PDFP-G48 Schematic

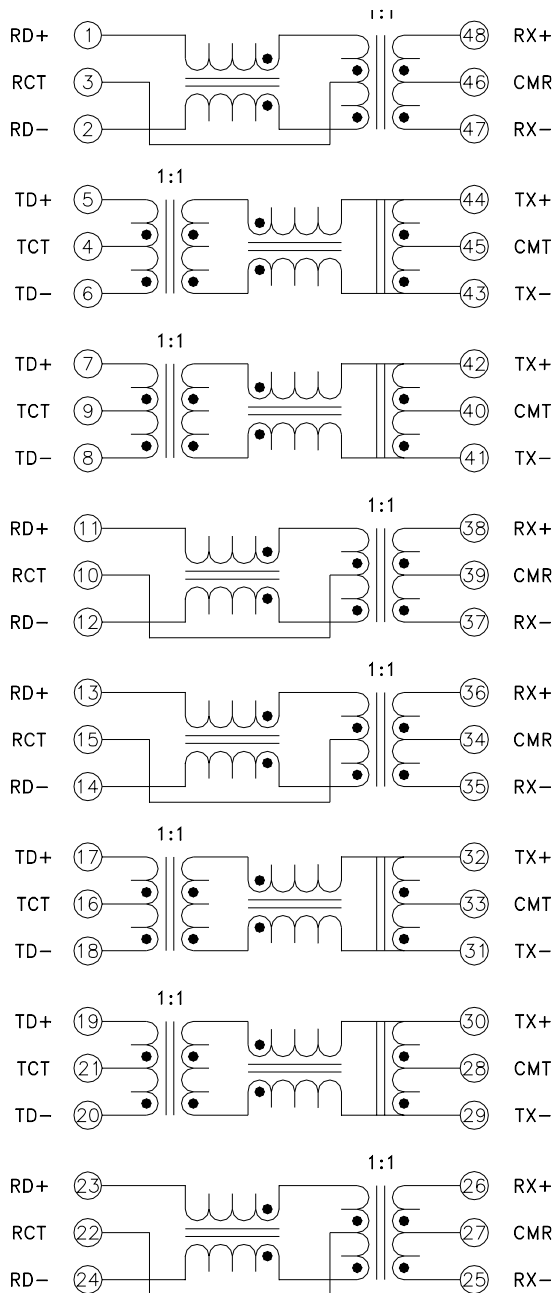

# Discrete Single Port Gigabit PoE PDFP-G24



LANDatacom

### Typical Common Electrical Characteristics<sup>1</sup>

Inductance	350uH Min.	0.1Vrms, 100kHz, 8mADC
Dielectric Rating	1500VAC	for 1 minute
Insertion Loss	-1.2dB max.	300kHz-125MHz
Return Loss	-18dB min.	500kHz-40MHz
	-15dB min.	40MHz-60MHz
	-12dB min.	60MHz-80MHz
	-10dB min.	80MHz-100MHz
Cross Talk	-35dB min.	300kHz-100MHz
Common Mode Rejection	-42dB min.	300kHz-32MHz
	-33dB min.	32MHz-100MHz

Note1: See specification sheet for electrical characteristic

### Features

- Meets IEEE 802.3af standard
- Surface mount
- Transfer mold package
- Optional pin-outs
- Industry standard footprint
- Optimum performance
- Cost Effective
- Both RoHS compliant and lead-terminal parts available

Part Number	Turns Ratio	Operating		
		Temp. Range	Schematic	Mechanical
000-7407-37	1CT:1CT	0°C to +70°C	1	1
749023015	1CT:1CT	0°C to +70°C	2	2
749023016	1CT:1CT	0°C to +70°C	3	2

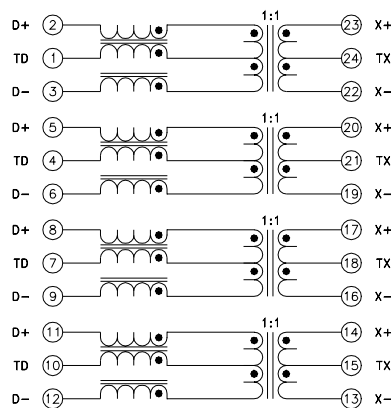

Schematic 1

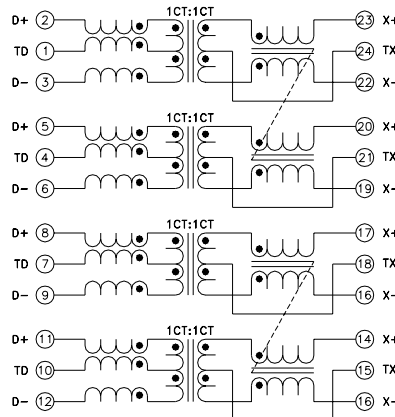

Schematic 2

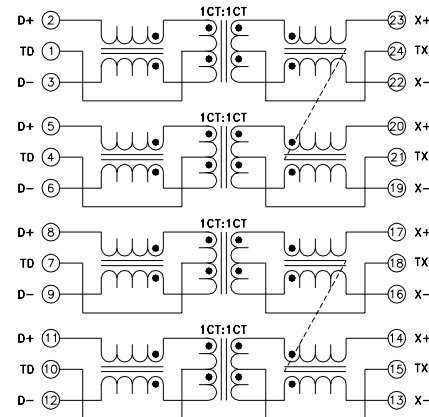

Schematic 3

5/01/08 Details subject to change. Contact your Midcom sales representative for additional information. Dimensions: in/mm. All tolerances are ± .010/0,25 and electrical specifications are @ 25°C unless otherwise specified.

### Mechanical 1

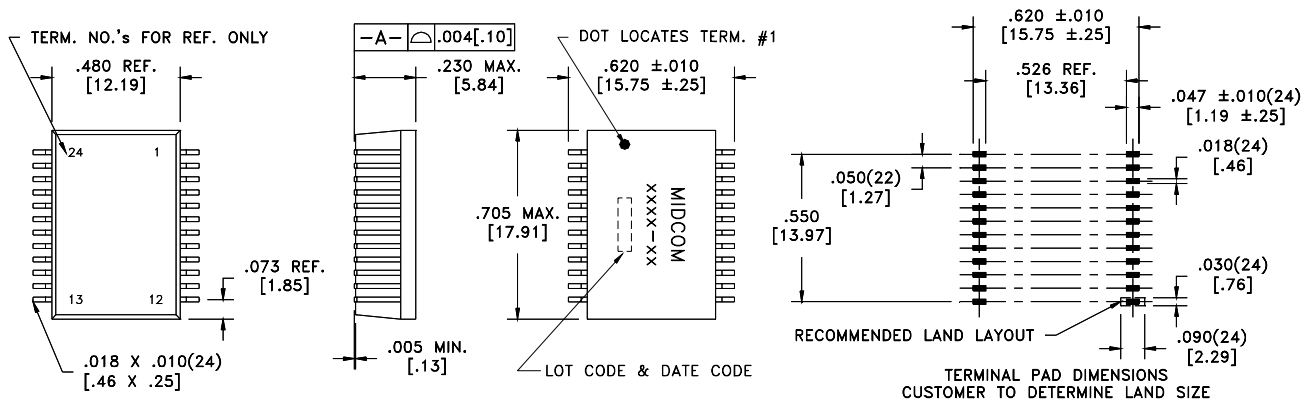

### Mechanical 2

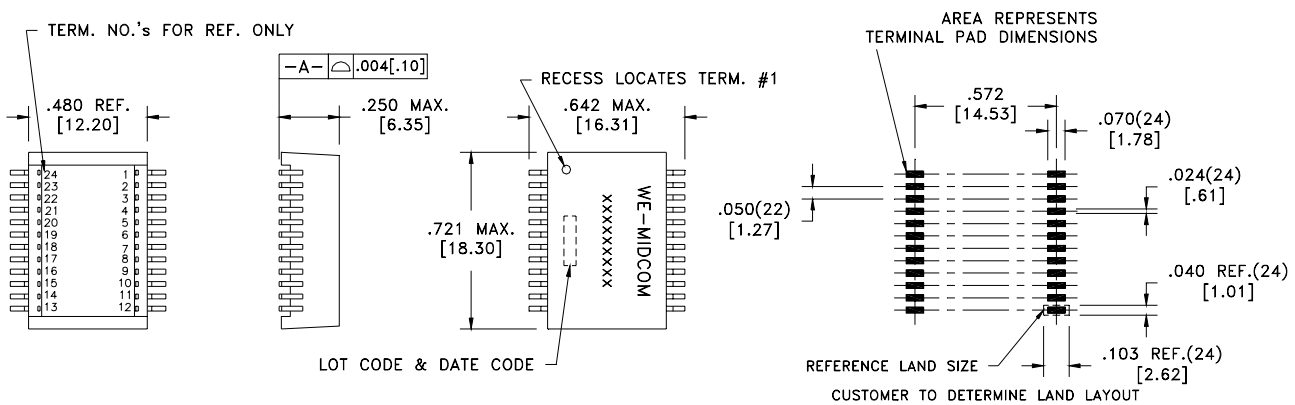

**Typical Common Electrical Characteristics<sup>1</sup>**

Inductance	350uH Min.	0.1Vrms, 100kHz, 8mADC
Dielectric Rating	1500VAC	for 1 minute
Insertion Loss	-1.0dB max.	1MHz-100MHz
Return Loss	-18dB min.	500KHz-40MHz
	-14dB min.	40MHz-60MHz
	-12dB min.	60MHz-80MHz
	-10dB min.	80MHz-100MHz
Cross Talk	-33dB min.	100k Hz-100MHz
Common Mode Rejection	-30dB min.	100k Hz-100MHz

Note1: See specification sheet for actual values as individual parts may vary.

**Features**

- Designed to handle 350mADC and meet IEEE 802.3af
- Dual port design
- Surface mount
- Optional pin-outs
- Industry standard connector footprint
- Optimum performance
- Cost effective
- Both RoHS compliant and lead-terminal parts available

Part Number	Turns Ratio	AutoMDIX Compatible	Operating Temp. Range	Schematic
000-7382-35	1CT:1CT	Yes	0°C to +70°C	1
749023022	1CT:1CT	Yes	-40°C to +85°C	2

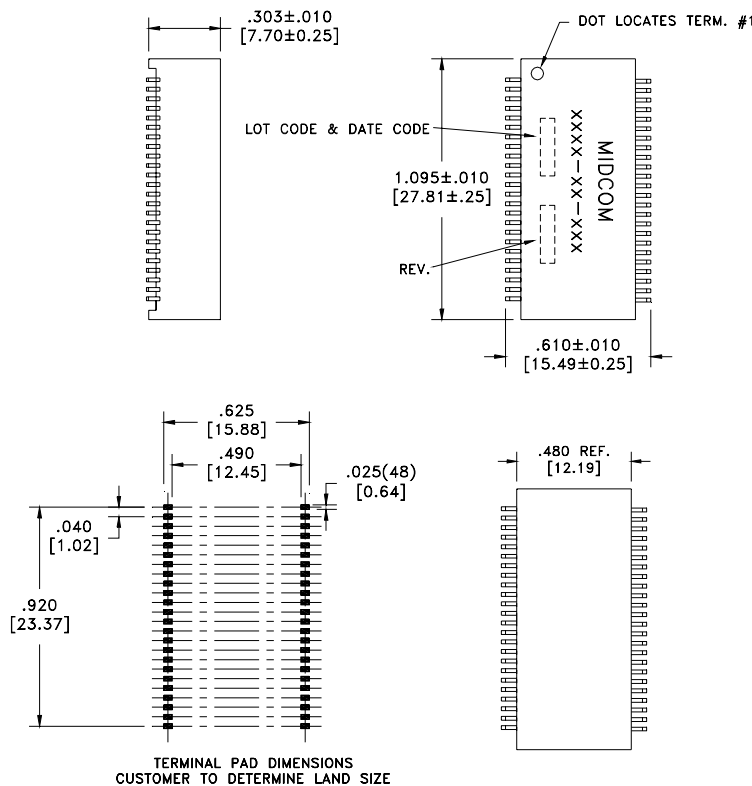

5/01/08 Details subject to change. Contact your Midcom sales representative for additional information. Dimensions: in/mm. All tolerances are ± .010/0,25 and electrical specifications are @ 25°C unless otherwise specified.

Schematic 1

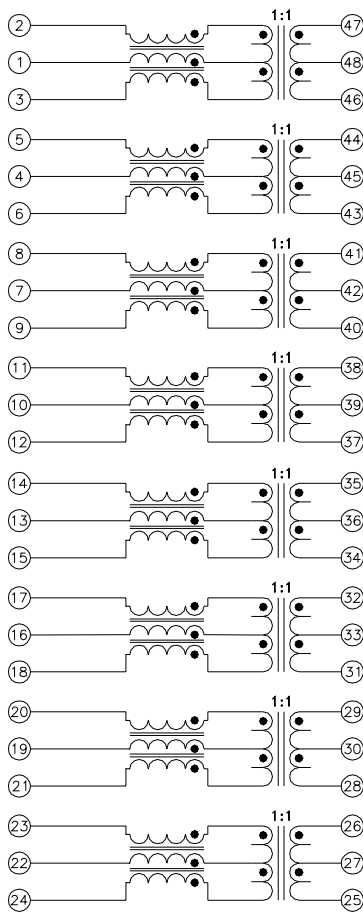

Schematic 2

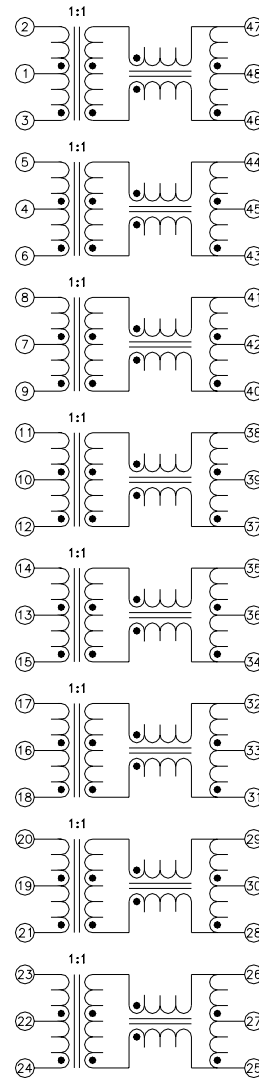

Typical Common Electrical Characteristics<sup>1</sup>

Inductance	350uH Min.	0.1Vrms, 100kHz, 15mADC
Dielectric Rating	1500VAC	for 1 minute
Insertion Loss	-1.0dB max.	300kHz-125MHz
Return Loss	-18dB min.	500KHz-40MHz
	-15dB min.	40MHz-60MHz
	-12dB min.	60MHz-80MHz
	-10dB min.	80MHz-100MHz
Cross Talk	-35dB min.	300kHz-100MHz
Common Mode Rejection	-42dB min.	300kHz-32MHz
	-33dB min.	32MHz-100MHz

Note1: See specification sheet for electrical characteristic

Features

- Meets IEEE 802.3 standard
- Surface mount
- Transfer mold package
- Optional pin-outs
- Industry standard footprint
- Optimum performance
- Cost Effective
- Both RoHS compliant and lead-terminal parts available

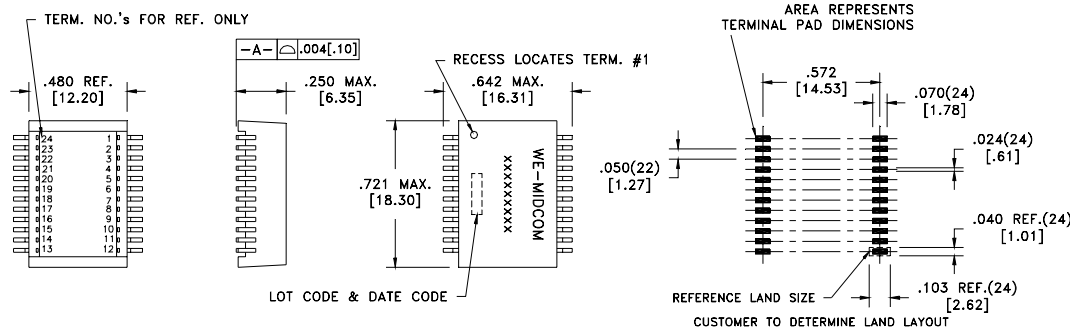

Operating

Part Number	Turns Ratio	Temp. Range	mADC
749022011	1CT:1CT	-40°C to +85°C	500

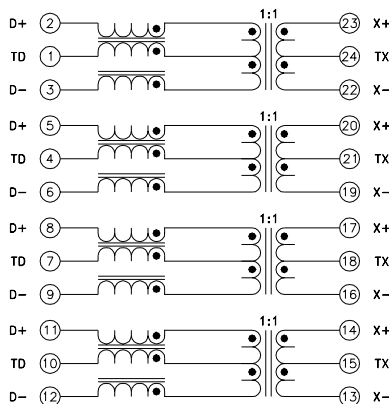

5/01/08 Details subject to change. Contact your Midcom sales representative for additional information. Dimensions: in/mm. All tolerances are ± .010/0,25 and electrical specifications are @ 25°C unless otherwise specified.

# Discrete Single Port 10 Base-T PDSO-G16

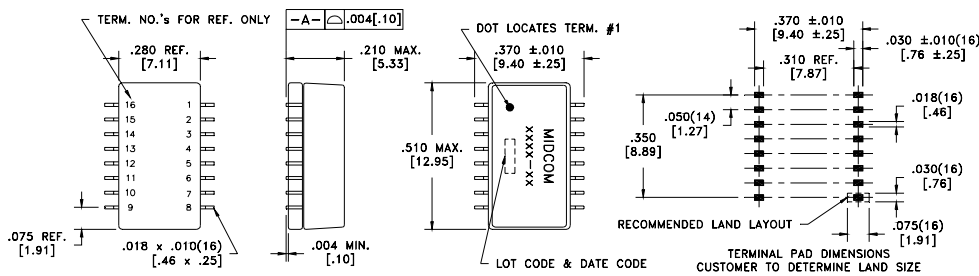

## Features

- Meets IEEE 802.3 standard
- Surface mount
- Transfer mold package
- Optional pin-outs
- Industry standard connector footprint
- Optimum performance
- Cost Effective
- Both RoHS compliant and lead-terminal parts available
- 1500VAC isolation for 1 minute

Part Number	Tx/Rx	Turns Ratio	Inductance	Leakage Inductance	Interwinding Capacitance	DC Resistance	Operating Temp. Range	Schematic
000-5368-30	Tx	1CT:1CT	200µH min.	0.2µH max.	15pF max.	0.3Ω max.	-20°C to +85°C	1
	Rx	1CT:1CT	200µH min.	0.2µH max.	15pF max.	0.3Ω max.		
000-5453-30	Tx	1CT:2CT	20µH min.	0.2µH max.	6pF max.	0.9Ω max.	-40°C to +85°C	2
	Rx	1CT:1CT	120µH min.	0.4µH max.	9pF max.	0.9Ω max.		
000-6084-30	Tx	1CT:1.4CT	140µH min.	0.5µH max.	15pF max.	0.5Ω max.	0°C to +70°C	1
	Rx	1CT:1CT	140µH min.	0.5µH max.	15pF max.	0.5Ω max.		
000-6122-30	Tx	1CT:1CT	140µH min.	0.5µH max.	15pF max.	0.5Ω max.	-40°C to +85°C	4
	Rx	1CT:1.4CT	140µH min.	0.5µH max.	15pF max.	0.5Ω max.		
000-6156-30	Tx	1CT:1.414CT	200µH min.	0.55µH max.	20pF max.	0.9Ω max.	-40°C to +85°C	2
	Rx	1CT:1CT	200µH min.	0.4µH max.	20pF max.	0.9Ω max.		
000-6169-30	Tx	1:2	20µH min.	0.08µH max.	6pF max.	0.3Ω max.	0°C to +70°C	3
	Rx	1:1	120µH min.	0.3µH max.	9pF max.	0.4Ω max.		
000-6936-37	Tx	1CT:1CT	100µH min.	0.3µH max.	9pF max.	0.3Ω max.	0°C to +70°C	1
	Rx	1CT:1CT	100µH min.	0.3µH max.	9pF max.	0.3Ω max.		
000-7196-37	Tx	1CT:2.5CT	200µH min.	0.5µH max.	15pF max.	0.4Ω max.	-40°C to +85°C	4
	Rx	1CT:1CT	200µH min.	0.5µH max.	15pF max.	0.4Ω max.		
000-7197-37	Tx	1CT:2.5CT	200µH min.	0.5µH max.	15pF max.	0.4Ω max.	0°C to +70°C	2
	Rx	1CT:1CT	200µH min.	0.5µH max.	15pF max.	0.4Ω max.		

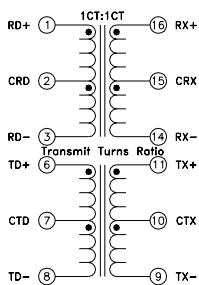

Schematic 1

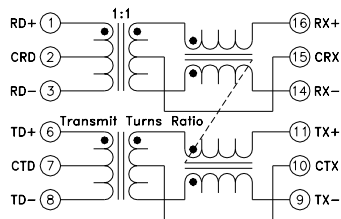

Schematic 2

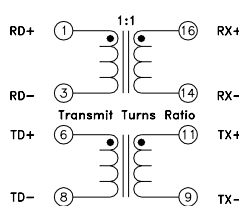

Schematic 3

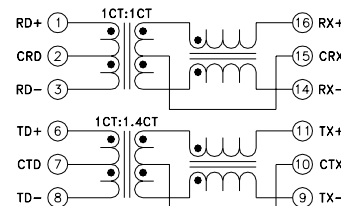

Schematic 4

Details subject to change. Contact your Midcom sales representative for additional information. Dimensions: in/mm. All tolerances are ± .010/0.25 and electrical specifications are @ 25°C unless otherwise specified.



# Discrete Single Port 10 Base-T Module with Filter PDFP-G16

## Typical Common Electrical Characteristics<sup>1</sup>

Dielectric Rating	1500VAC	for 1 minute
Insertion Loss	-1.0dB max.	1MHz-10MHz
Return Loss	-15dB min.	5MHz-10MHz
Cross Talk	-35dB min.	5MHz-10MHz
Attenuation Tx	-27dB min.	40MHz
Attenuation Rx	-27dB min.	40MHz

Note1: See specification sheet for individual part number specifications.

## Features

- Meets IEEE 802.3 standard
- Transfer molded package
- Surface mount
- Optional pin-outs
- Industry standard connector footprint
- Optimum performance
- Cost Effective
- Both RoHS compliant and lead-terminal parts available

Part Number	Transmit Turns Ratio	Operating Temp.	
		Range	Schematic
000-5408-37	1CT:1CT	-40°C to +85°C	1
000-5830-37	1CT:1CT	0°C to +70°C	2
000-7138-37	1:1.414CT	0°C to +70°C	3
000-7191-37	1:1.414CT	0°C to +70°C	3
000-7363-37	1:1.414CT	0°C to +70°C	3

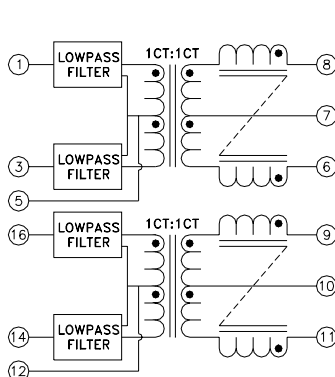
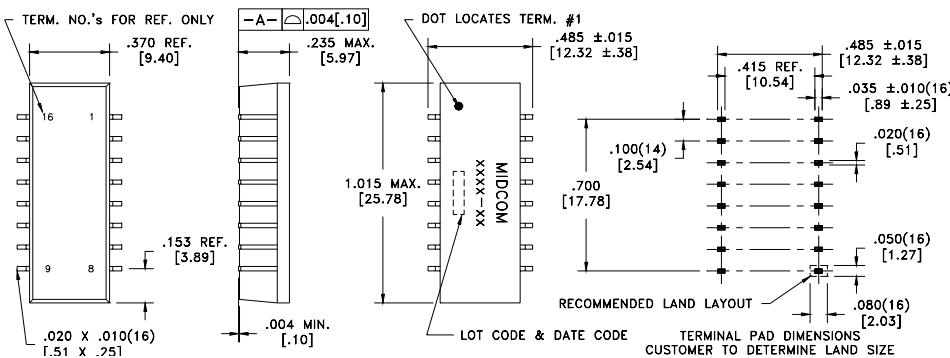

Schematic 1

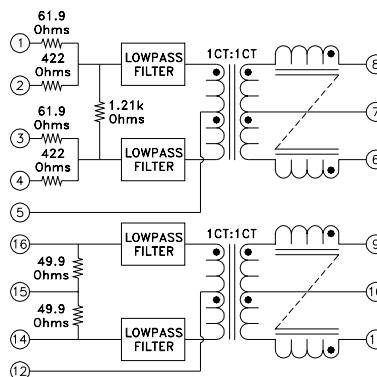

Schematic 2

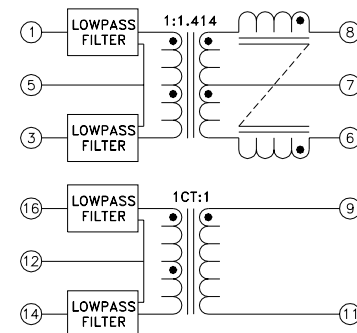

Schematic 3

5/01/08 Details subject to change. Contact your Midcom sales representative for additional information. Dimensions: in/mm. All tolerances are ±.010/0,25 and electrical specifications are @ 25°C unless otherwise specified.

# Discrete Quad Port 10 Base-T PDFP-G40

## Common Electrical Characteristics

Dielectric Rating	1500VAC	for 1 minute
Insertion Loss	-1dB max.	1MHz-10MHz
Return Loss	-15dB min.	5MHz-10MHz
Cross Talk	-35dB min.	5MHz-10MHz

## Features

- Meets IEEE 802.3 standards
- Dual port configuration
- Surface mount
- Transfer mold package
- Optional pin-outs
- Industry standard connector footprint
- Optimum performance
- Cost Effective
- Both RoHS compliant and lead-terminal parts available

Part Number	Transmit Turns Ratio	Inductance (0.1Vrms, 100kHz)	Operating Temp. Range	Schematic
000-6309-37	1CT:1CT	280µH	0°C to +70°C	1
000-6961-37	1CT:1.4CT	140µH	0°C to +70°C	2
000-6964-37	1CT:2CT	200µH	0°C to +70°C	3

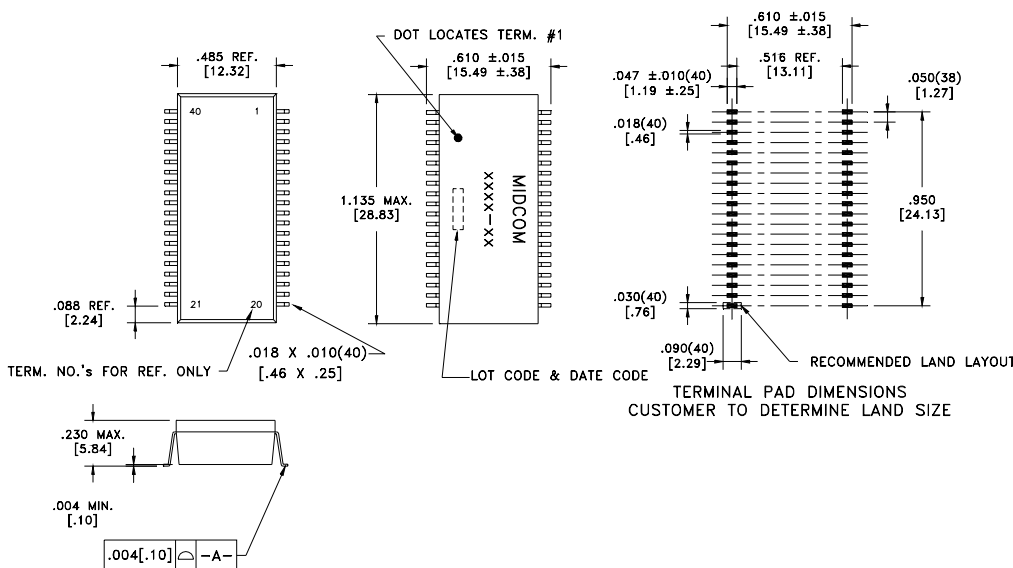

Details subject to change. Contact your Midcom sales representative for additional information. Dimensions: in/mm. All tolerances are ± .010/0.25 and electrical specifications are @ 25°C unless otherwise specified.

# Discrete Quad Port 10 Base-T PDFP-G40 Schematics

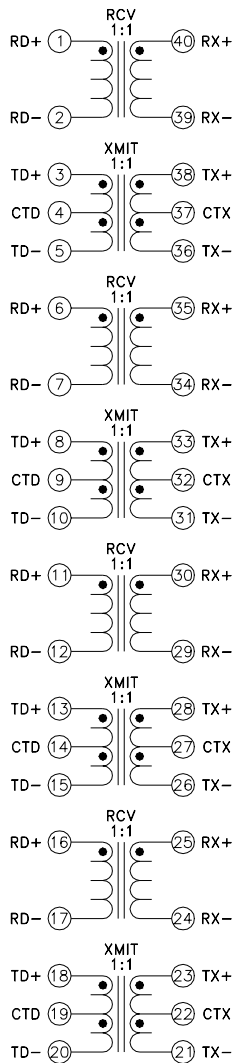

**Schematic 1**

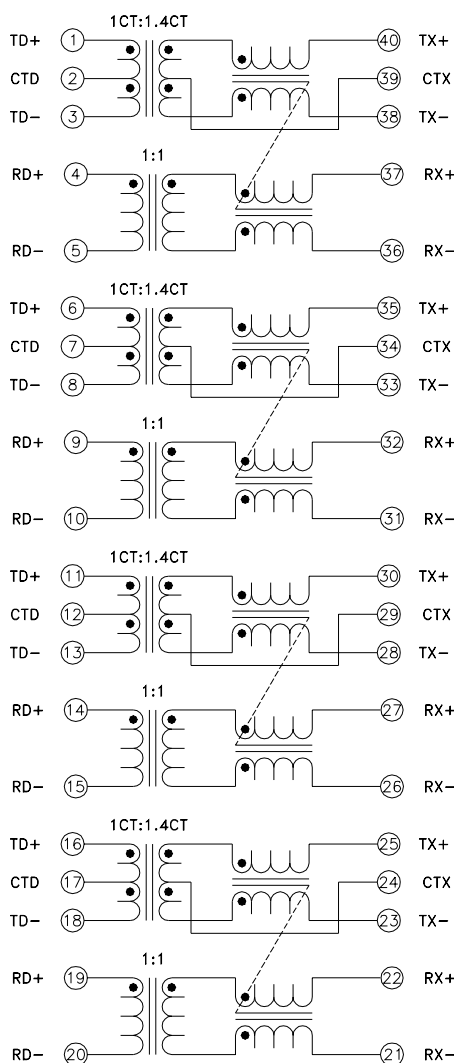

**Schematic 2**

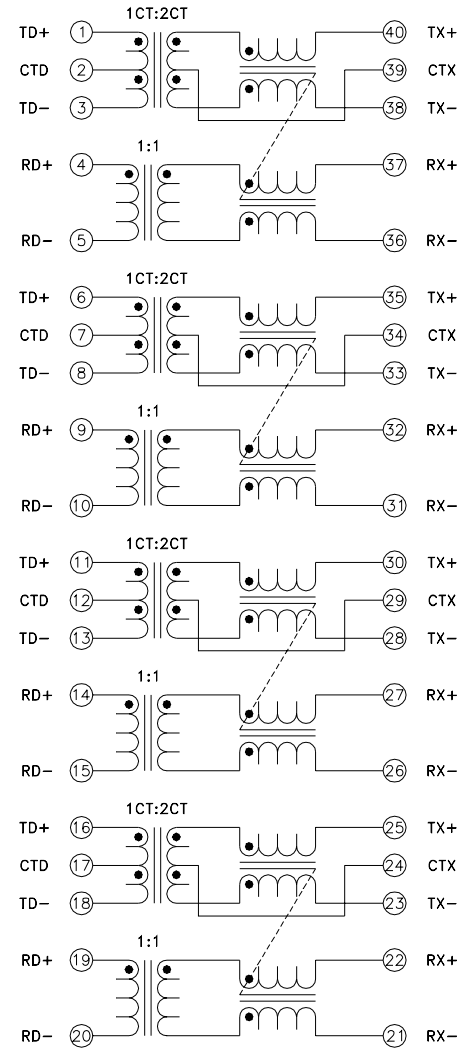

**Schematic 3**

# Discrete Single Port 10/100 Base-T PCMCIA AEDFP-G16

## Typical Common Electrical Characteristics<sup>1</sup>

Inductance	350uH Min.	0.1Vrms, 100kHz, 8mADC
Dielectric Rating	1500VAC	for 1 minute
Insertion Loss	-1.1dB max.	100kHz-100MHz
Return Loss	-17dB min.	1MHz-30MHz
	-15.5dB min.	30MHz-45MHz
	-13dB min.	45MHz-60MHz
	-11dB min.	60MHz-80MHz
Cross Talk	-30dB min.	100kHz-100MHz
Common Mode Rejection	-30dB min.	100kHz-100MHz

## Features

- PCMCIA compatible profile
- Meets IEEE 802.3 standard
- Surface mount
- Optional pin-outs
- Industry standard connector footprint
- Optimum performance
- Cost Effective
- Both RoHS compliant and lead-terminal parts available

Part Number	Transmit Turns Ratio	AutoMDIX Compatible	Operating Temp. Range	Schematic
000-7112-35	1CT:1CT	No	0°C to +70°C	1
000-7148-35	1CT:1.4CT	No	0°C to +70°C	2
000-7218-35	1CT:1CT	Yes	0°C to +70°C	2

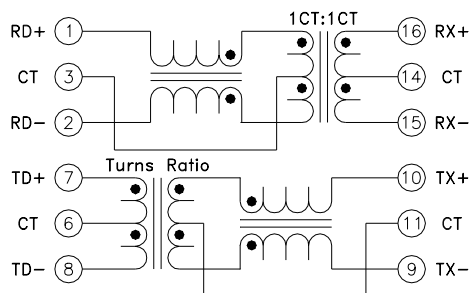
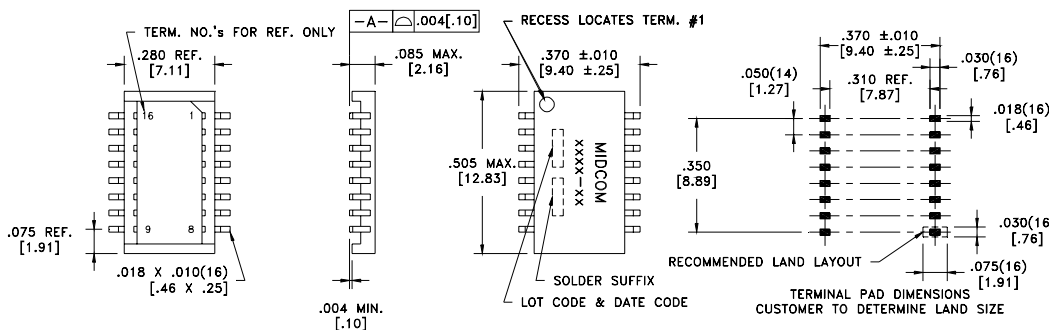

**Schematic 1**

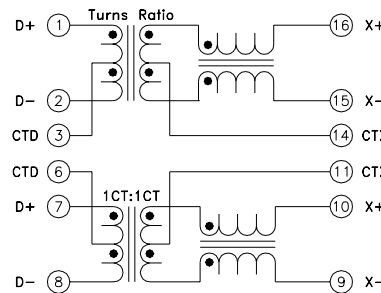

**Schematic 2**

Note1: The 000-7342-37 is missing terminal 4, 5, 12 and 13.

Note2: Typical min. and max. electrical characteristics only, see specification sheets for actual characteristics.

### Features

- Meets IEEE 802.3 standard
- Surface mount
- Optional pin-outs
- Industry standard connector foot-print
- Optimum performance
- Cost Effective
- Both RoHS compliant and lead-terminal parts available

### Common Electrical Characteristics

Inductance	350µH Min.	0.1Vrms, 100kHz, 8mADC
Dielectric Rating	1500VAC	for 1 minute
Transmit Turns Ratio	1CT:1CT	±2%
Receive Turns Ratio	1CT:1CT	±2%

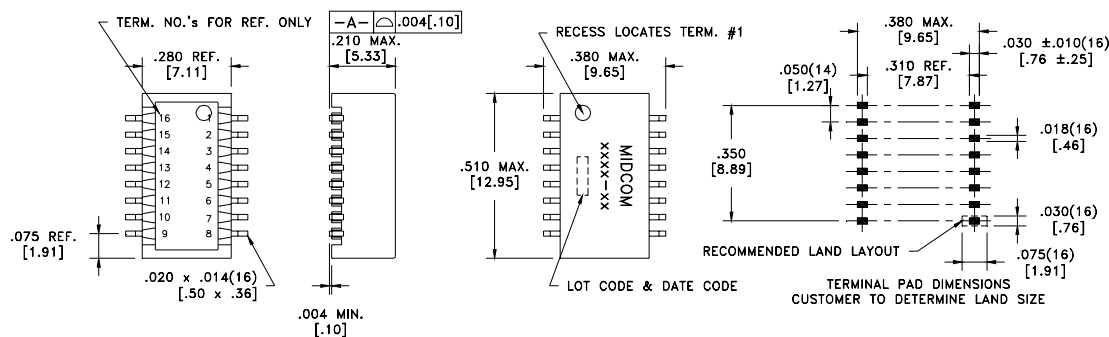

Part Number	Insertion Loss		Return Loss			Cross talk	CMRR	Auto-	Operating	Schematic
	1M-100MHz	1M-30MHz	30M-60MHz	60M-80MHz	80M-100MHz	1M-100MHz	1M-100MHz	MDIX	Temp. Range	
000-7090-30	-1.1dB max.	-18dB min.	-16dB min.	-12dB min.	-	-30dB min.	-30dB min.	Yes	-40°C to +85°C	1
000-7159-30	-1.0dB max.	-20.5dB min.	-17dB min.	-14dB min.	-12dB min.	-40dB min.	-40dB min.	No	0°C to +70°C	2
000-7160-30	-1.0dB max.	-20.dB min.	-17dB min.	-14dB min.	-12dB min.	-40dB min.	-40dB min.	No	0°C to +70°C	3
000-7183-30	-1.0dB max.	-20.dB min.	-17dB min.	-14dB min.	-12dB min.	-40dB min.	-40dB min.	No	0°C to +70°C	4
000-7184-30	-1.0dB max.	-20.dB min.	-17dB min.	-14dB min.	-12dB min.	-40dB min.	-40dB min.	No	0°C to +70°C	3
000-7190-30	-1.0dB max.	-20.dB min.	-17dB min.	-14dB min.	-12dB min.	-40dB min.	-40dB min.	No	0°C to +70°C	5
000-7192-30	-1.0dB max.	-20.dB min.	-17dB min.	-14dB min.	-12dB min.	-40dB min.	-40dB min.	Yes	0°C to +70°C	6
000-7318-30	-1.1dB max.	-18dB min.	-16dB min.	-12dB min.	-	-35dB min.	-30dB min.	Yes	0°C to +70°C	1
000-7430-30	-1.1dB max.	-18.dB min.	-16dB min.	-14dB min.	-12dB min.	-35dB min.	-30dB min.	Yes	-25°C to +105°C	1

# Discrete Single Port 10/100 Base-T EDSO-G16

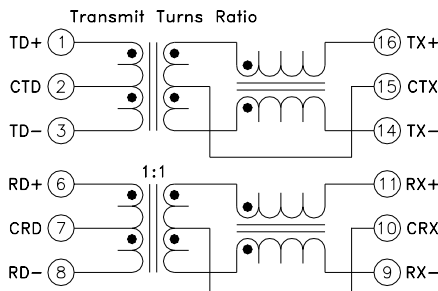

**Schematic 1**

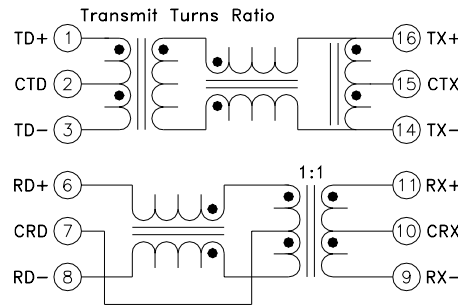

**Schematic 2**

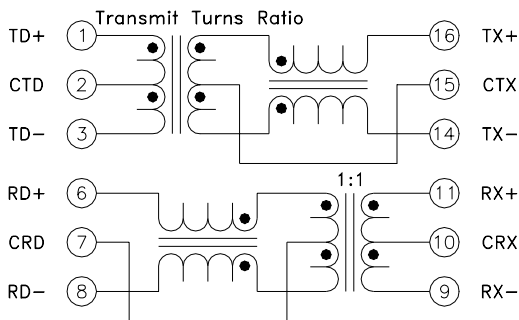

**Schematic 3**

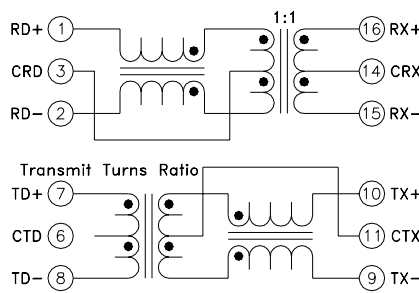

**Schematic 4**

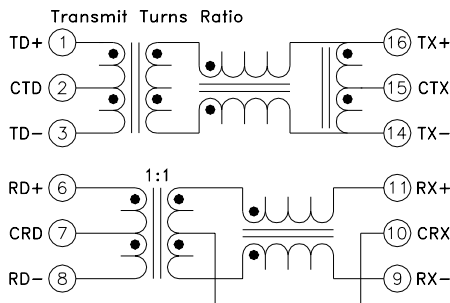

**Schematic 5**

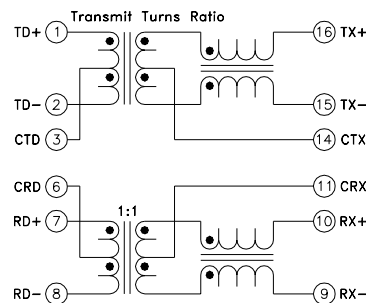

**Schematic 6**

**Discrete Single Port  
10/100 Base-T PDSO-G16**



LANDatacom

**Typical Common Electrical Characteristics<sup>1</sup>**

Inductance	350uH Min.	0.1Vrms, 100kHz, 8mADC
Dielectric Rating	1500VAC	for 1 minute
Insertion Loss	-1.1dB max.	500kHz-100MHz
Return Loss	-18dB min.	500kHz-30MHz
	-16dB min.	30MHz-45MHz
	-14dB min.	45MHz-60MHz
	-12dB min.	60MHz-80MHz
Cross Talk	-35dB min.	1MHz-100MHz
Common Mode Rejection	-30dB min.	500kHz-100MHz
Diff. To Common Mode Rejection	-30dB min.	500kHz-100MHz

Note1: See specification sheet for actual electrical characteristics

**Features**

- Meets IEEE 802.3 standard
- Surface mount
- Transfer mold package
- Optional pin-outs
- Industry standard footprint
- Optimum performance
- Cost Effective
- Both RoHS compliant and lead-terminal parts available

Part Number	Transmit Turns Ratio	AutoMDIX Compatible	Operating Temp. Range
000-7090-37	1CT:1CT	Yes	-40°C to +85°C
000-7091-37	1CT:1.89CT	No	0°C to +70°C
000-7092-37	1.414CT:1CT	No	0°C to +70°C
7490100123	1.414CT:1CT	No	0°C to +70°C
000-7041-37	1CT:1CT	No	0°C to +70°C
000-7213-37	1CT:1CT	Yes	0°C to +70°C
000-7315-37	1CT:1CT	Yes	-40°C to +85°C
000-7313-37	1CT:1CT	Yes	0°C to +70°C
000-7342-37 <sup>2</sup>	1CT:1CT	Yes	-40°C to +85°C

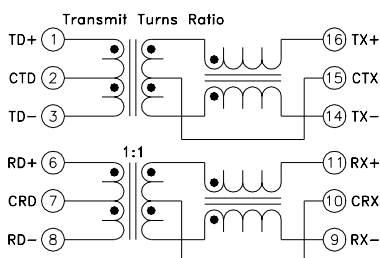
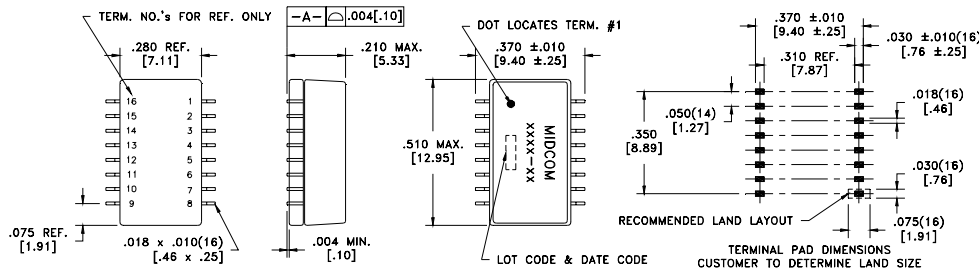

**Schematic 1**

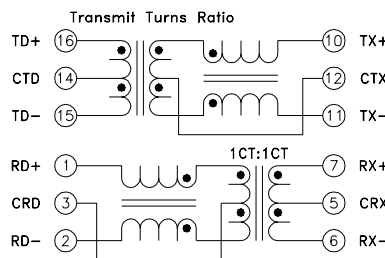

**Schematic 2**

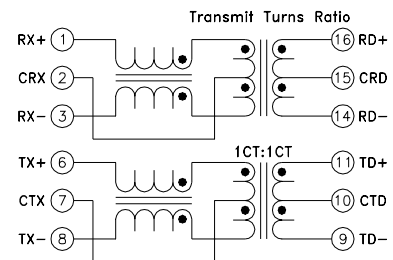

**Schematic 3**

Note1: See specification sheet for individual part number specifications.  
Note2: The 000-7342-37 is missing terminals 4, 5, 12 and 13.

5/01/08 Details subject to change. Contact your Midcom sales representative for additional information. Dimensions: in/mm. All tolerances are ±.010/0.25 and electrical specifications are @ 25°C unless otherwise specified.

Typical Common Electrical Characteristics<sup>1</sup>

Inductance	350uH Min.	0.1Vrms, 100kHz, 8mADC
Dielectric Rating	1500VAC	for 1 minute
Insertion Loss	-1.1dB max.	300kHz-100MHz
Return Loss	-18dB min.	500kHz-30MHz
	-16dB min.	30MHz-45MHz
	-14dB min.	45MHz-60MHz
	-12dB min.	60MHz-80MHz
Cross Talk	-38dB min.	300kHz-100MHz
Diff. To Common Mode Rejection	-38dB min.	300kHz-100MHz

Note1: See specification sheet for actual electrical characteristics

Features

- Meets IEEE 802.3 standards
- Dual port configuration
- Surface mount
- Transfer mold package
- Optional pin-outs
- Industry standard connector footprint
- Optimum performance
- Cost Effective
- Both RoHS compliant and lead-terminal parts available

Part Number	Transmit Turns Ratio	AutoMDIX Compatible	Operating Temp. Range	Schematic
000-6120-37 <sup>2</sup>	1CT:1CT	No	0°C to +70°C	1
000-6181-37 <sup>3</sup>	1CT:1CT	No	-40°C to +85°C	2
000-6241-37	1CT:1CT	No	-40°C to +85°C	2
000-6254-37	1CT:2CT	No	0°C to +70°C	3
000-6265-37	1CT:1CT	No	0°C to +70°C	4
000-6789-37	1CT:1.414CT	No	0°C to +70°C	5
000-6812-37	1CT:1.25CT	No	0°C to +70°C	6
000-7086-37	1.4CT:1CT	No	0°C to +70°C	7
000-7362-37	1CT:1CT	No	-40°C to +85°C	6

Note2: Missing terminals 5 and 11 for keying purposes.

Note3: Missing terminals 4 and 13 for keying purposes.

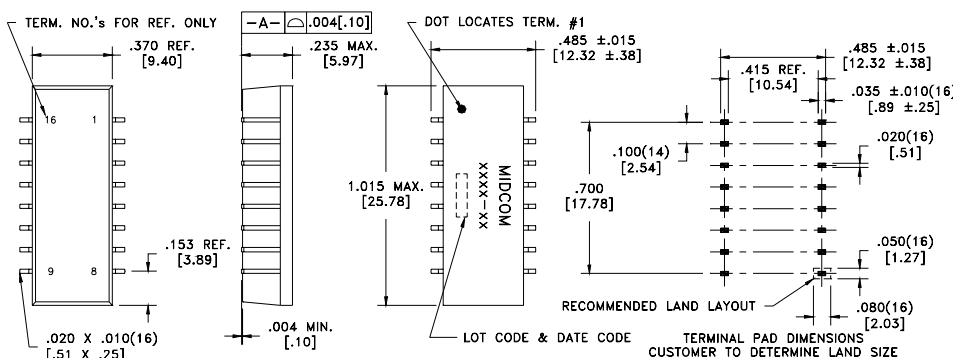

Details subject to change. Contact your Midcom sales representative for additional information. Dimensions: in/mm. All tolerances are ± .010/0.25 and electrical specifications are @ 25°C unless otherwise specified.



# Discrete Single Port 10/100 Base-T PDFP-G16 Schematics

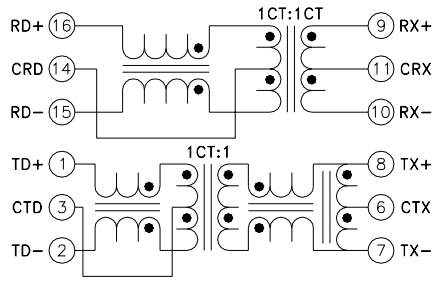

**Schematic 1**

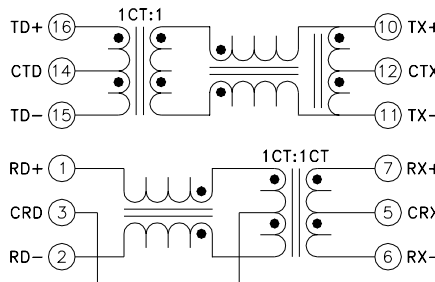

**Schematic 2**

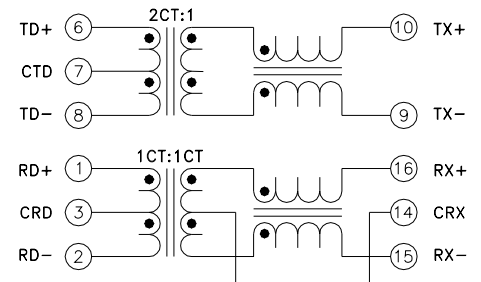

**Schematic 3**

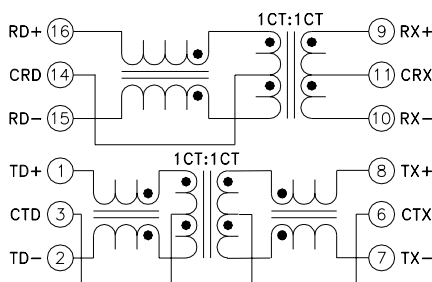

**Schematic 4**

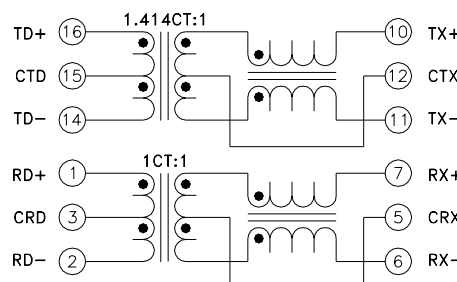

**Schematic 5**

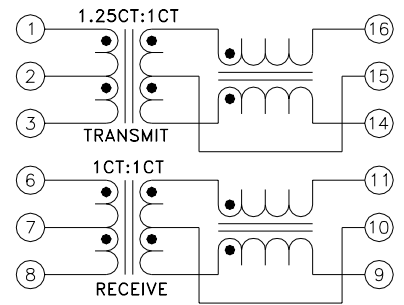

**Schematic 6**

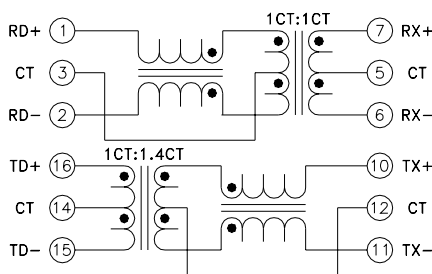

**Schematic 7**

# Discrete Dual Port 10/100 Base-T PDFP-G24

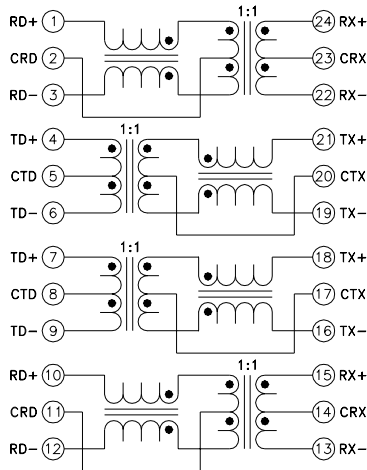

## Features

- Meets IEEE 802.3 standards
- Surface mount
- Transfer mold package
- Optional pin-outs
- Industry standard connector footprint
- Optimum performance
- Cost Effective
- Both RoHS compliant and lead-terminal parts available

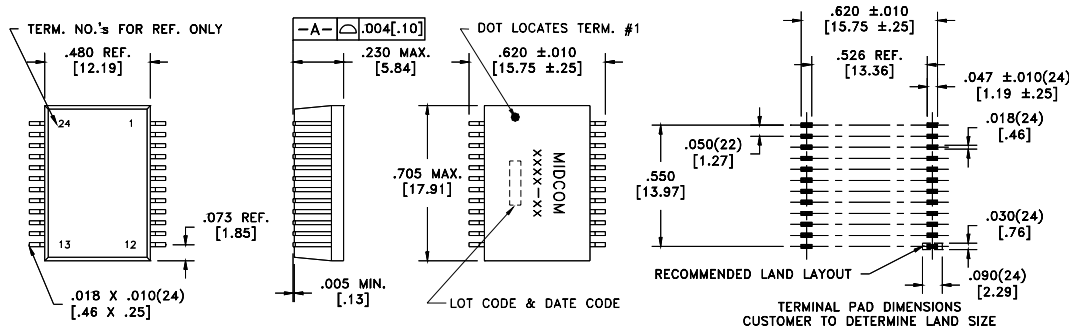

Part Number	Turns Ratio	AutoMDIX Compatible	Operating Temp. Range
000-7142-37	1CT:1CT	No	0°C to +70°C

### Typical Common Electrical Characteristics

Inductance	350uH Min.	0.1Vrms, 100kHz, 8mADC
Dielectric Rating	1500VAC	for 1 minute
Insertion Loss	-1.1dB max.	1MHz-100MHz
Return Loss	-18dB min.	1MHz-30MHz
	-16dB min.	30MHz-40MHz
	-14dB min.	40MHz-60MHz
	-12dB min.	60MHz-80MHz
Cross Talk	-35dB min.	1MHz-100MHz
Common Mode Rejection	-35dB min.	1MHz-100MHz

Details subject to change. Contact your Midcom sales representative for additional information. Dimensions: in/mm. All tolerances are ± .010/0.25 and electrical specifications are @ 25°C unless otherwise specified.

# Discrete Dual Port 10/100 Base-T PDFP-G40

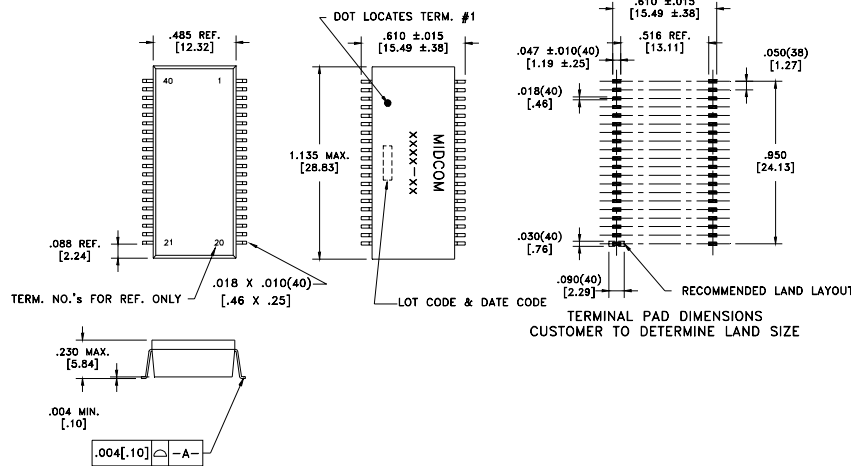

## Features

- Meets IEEE 802.3 standards
- Dual port configuration
- Surface mount
- Transfer mold package
- Optional pin-outs
- Industry standard connector footprint
- Optimum performance
- Cost Effective
- Both RoHS compliant and lead-terminal parts available

### AutoMDIX Operating Temp.

Part Number	Turns Ratio	Compatible	Range	Schematic
000-6809-37	1CT:1CT	No	0°C to +70°C	1
000-6815-37	1CT:1CT	No	0°C to +70°C	2
000-6824-37	1CT:1CT	Yes	0°C to +70°C	3

### Common Electrical Characteristics

Inductance	350uH Min.	0.1Vrms, 100kHz, 8mADC
Dielectric Rating	1500VAC	for 1 minute
Insertion Loss	-1.1dB max.	500kHz-100MHz
Return Loss	-18dB min.	500kHz-30MHz
	-16dB min.	30MHz-45MHz
	-14dB min.	45MHz-60MHz
	-12dB min.	60MHz-80MHz
	-10dB min.	80MHz-100MHz
Cross Talk	-35dB min.	500kHz-100MHz
Common Mode Rejection	-30dB min.	1MHz-100MHz
Diff. To Common Mode Rejection	-35dB min.	1MHz-100MHz

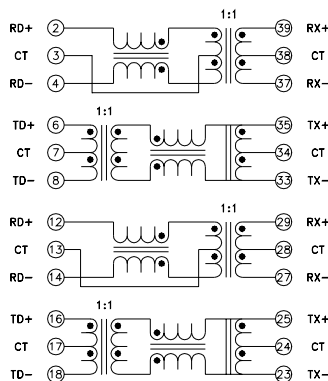

Schematic 1

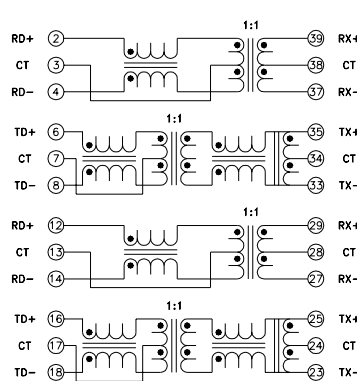

Schematic 2

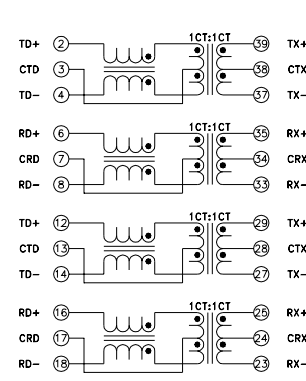

Schematic 3

Typical Common Electrical Characteristics<sup>1</sup>

Inductance	350uH Min.	0.1Vrms, 100kHz, 8mADC
Dielectric Rating	1500VAC	for 1 minute
Insertion Loss	-1.1dB max.	300kHz-100MHz
Return Loss	-18dB min.	500kHz-30MHz
	-16dB min.	30MHz-45MHz
	-14dB min.	45MHz-60MHz
	-12dB min.	60MHz-80MHz
Cross Talk	-38dB min.	300kHz-100MHz
Diff. To Common Mode Rejection	-38dB min.	300kHz-100MHz

Note1: See specification sheet for actual electrical characteristics

Features

- Meets IEEE 802.3 standards
- Quad port configuration
- Surface mount
- Transfer mold package
- Optional pin-outs
- Industry standard connector footprint
- Optimum performance
- Cost Effective
- Both RoHS compliant and lead-terminal parts available

Part Number	Transmit Turns Ratio	Auto MDIX	Operating Temp. Range	Schematic
000-6886-37	1CT:1CT	No	-40°C to +85°C	1
000-6887-37	1CT:1CT	No	-40°C to +85°C	2
000-6931-37	1CT:1CT	No	-40°C to +85°C	3
000-6945-37	1CT:1CT	No	-40°C to +85°C	4
000-6949-37	1CT:1CT	No	-40°C to +85°C	5
000-7095-37	1CT:1.89CT	No	0°C to +70°C	6
000-7120-37	1CT:1CT	Yes	0°C to +70°C	7
000-7352-37	1CT:1CT	Yes	0°C to +70°C	8

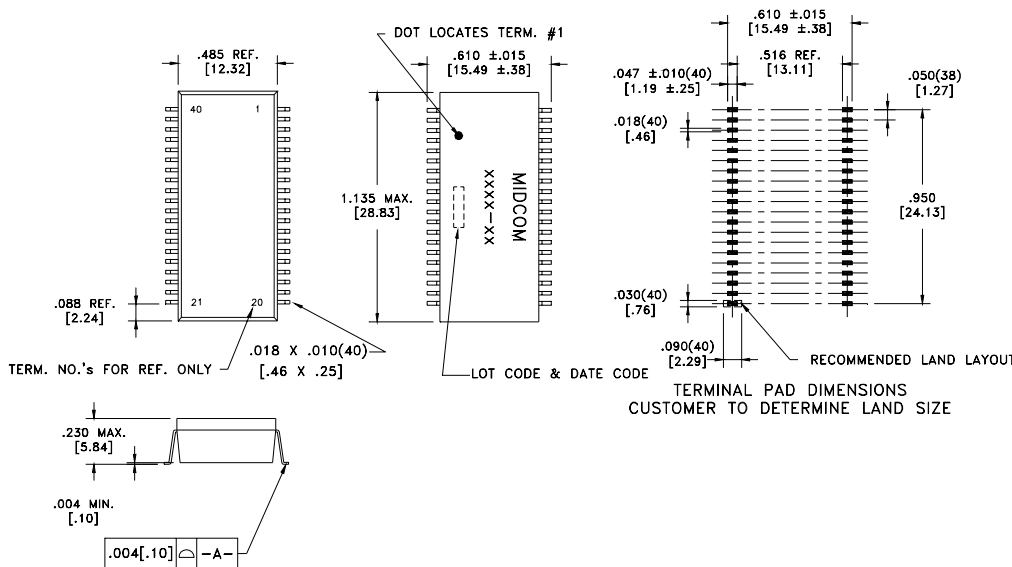

Details subject to change. Contact your Midcom sales representative for additional information. Dimensions: in/mm. All tolerances are ± .010/0.25 and electrical specifications are @ 25°C unless otherwise specified.

# Discrete Quad Port 10/100 Base-T PDFP-G40 Schematics

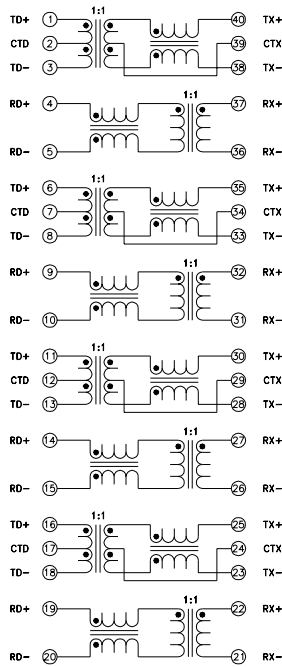

**Schematic 1**

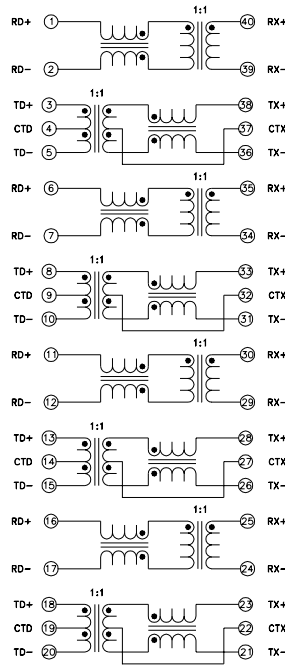

**Schematic 2**

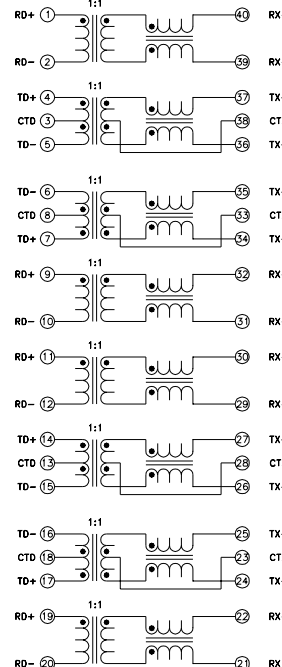

**Schematic 3**

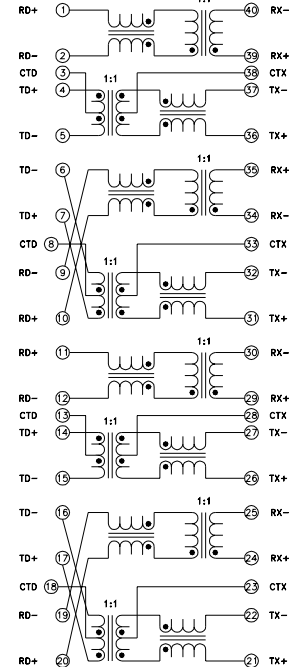

**Schematic 4**

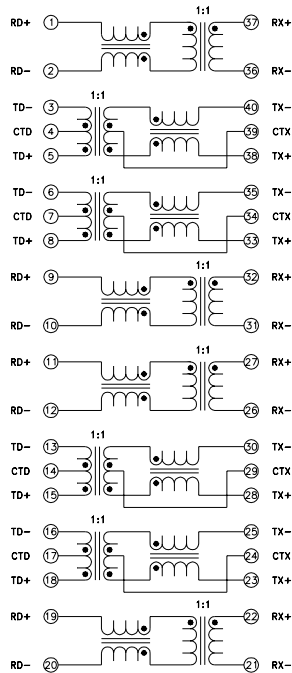

**Schematic 5**

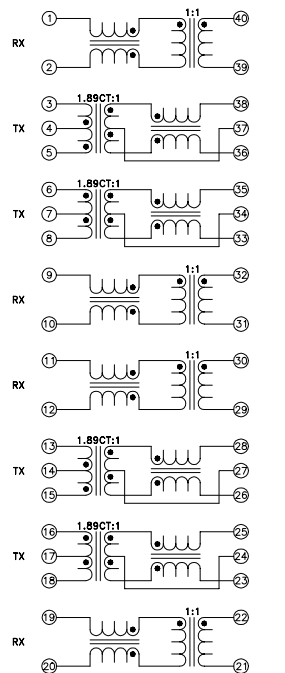

**Schematic 6**

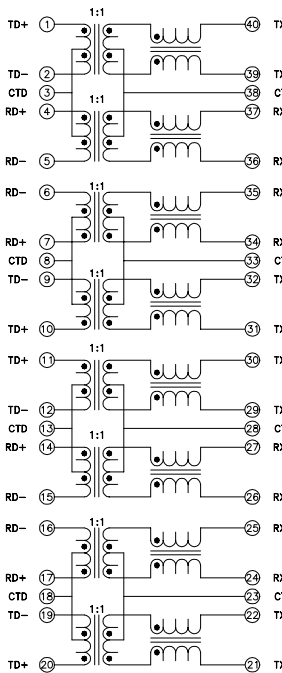

**Schematic 7**

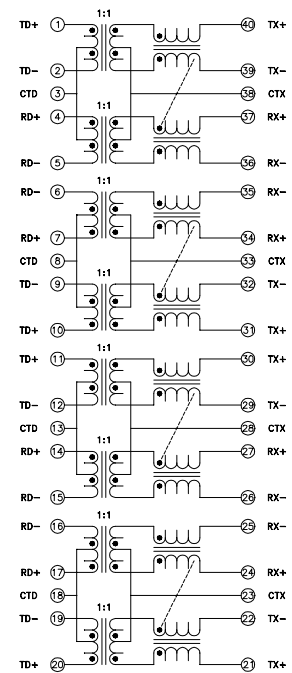

**Schematic 8**

5/01/08 Details subject to change. Contact your Midcom sales representative for additional information. Dimensions: in/mm. All tolerances are ± .010/0,25 and electrical specifications are @ 25°C unless otherwise specified.

**Typical Common Electrical Characteristics**

Inductance	350uH Min.	0.1Vrms, 100kHz, 8mADC
Dielectric Rating	1500VAC	for 1 minute
Insertion Loss	-1.0dB max.	300kHz-125MHz
Return Loss	-18dB min.	1MHz-40MHz
	-15dB min.	40MHz-60MHz
	-12dB min.	60MHz-80MHz
	-10dB min.	80MHz-100MHz
Cross Talk	-35dB min.	1MHz-150MHz
Common Mode Rejection	-42dB min.	1MHz-32MHz
	-33dB min.	32MHz-150MHz

Note1: The 000-7382-35 is missing terminal 4, 5, 12 and 13

**Features**

- PCMCIA compatible profile
- Meets IEEE 802.3 standard
- Surface mount
- Optional pin-outs
- Industry standard connector footprint
- Optimum performance
- Cost Effective
- Both RoHS compliant and lead-terminal parts available

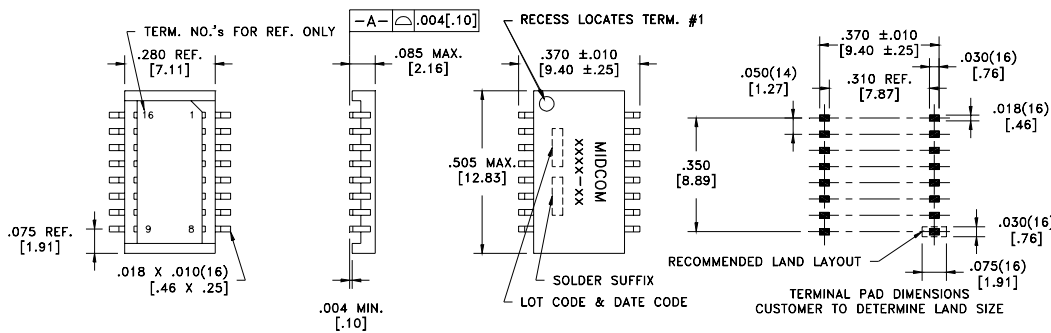

**AutoMDIX Operating**

Part Number	Turns Ratio	Compatible	Temp. Range	Schematic
000-7382-35	1CT:1CT	Yes	0°C to +70°C	1

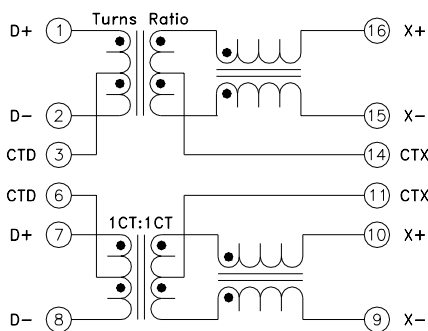

**Schematic 1**



**Discrete Single Port 10/100  
Medical High Voltage**

**Midcom**

LANDatacom

**Typical Common Electrical Characteristics<sup>1</sup>**

Inductance	350uH Min.	0.1Vrms, 100kHz, 8mADC
Dielectric Rating	4000VAC	for 1 minute
Insertion Loss	-1.2dB max.	500k Hz-100MHz
Return Loss	-18dB min.	500k Hz-30MHz
	-15dB min.	30MHz-45MHz
	-13dB min.	45MHz-60MHz
	-10dB min.	60MHz-80MHz
Cross Talk	-40dB min.	1MHz-100MHz
Common Mode Rejection	-30dB min.	500k Hz-100MHz
Diff. To Common Mode Rejection	-33dB min.	500k Hz-100MHz

Note1: See specification sheet for actual electrical characteristics

**Features**

- Designed for Medical Applications
- Meets IEEE 802.3 standard
- Surface mount
- Optional pin-outs
- Optimum performance
- Standard and PoE versions
- Cost Effective
- RoHS compliant
- Operating Temp 0°C to +70°C

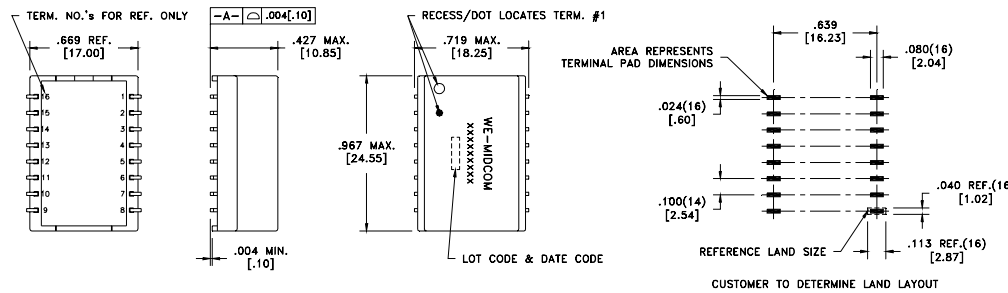

Part Number	Transmit Turns Ratio	AutoMDIX Compatible	Power Capability	Schematic
749014011	1CT:1CT	No	Standard	1
479014012	1CT:1CT	Yes	Standard	2
749014013	1CT:1CT	Yes	PoE	3

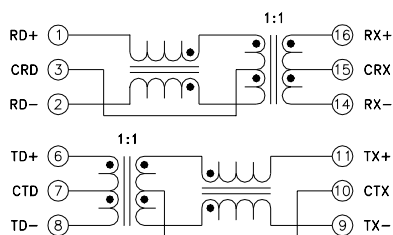

**Schematic 1**

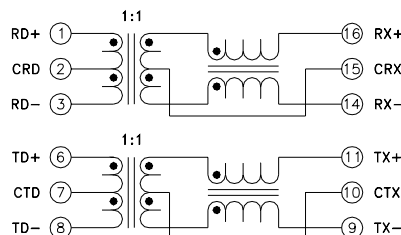

**Schematic 2**

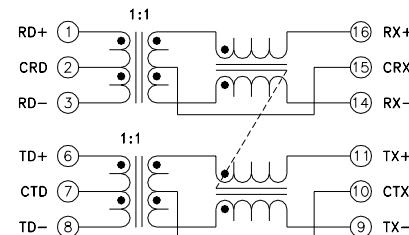

**Schematic 3**

Note1: See specification sheet for individual part number specifications.

Note2: The 000-7342-37 is missing terminals 4, 5, 12 and 13.

**Typical Common Electrical Characteristics<sup>1</sup>**

Dielectric Rating	1500VAC	for 1 minute
Insertion Loss	-1.0dB max.	300kHz-100MHz
Return Loss	-18dB min.	500kHz-40MHz
	-15dB min.	40MHz-60MHz
	-12dB min.	60MHz-80MHz
	-10dB min.	80MHz-100MHz
Cross Talk	-35dB min.	300kHz-100MHz
Common Mode Rejection	-42dB min.	300kHz-32MHz
	-33dB min.	32MHz-100MHz

Note1: See specification sheet for electrical characteristic

**Features**

- Meets IEEE 802.3 standard
- Surface mount
- Transfer mold package
- Optional pin-outs
- Industry standard footprint
- Optimum performance
- Cost Effective
- Both RoHS compliant and lead-terminal parts available

Part Number	Turns Ratio	Operating Temp. Range	Schematic	Mechanical
000-7412-35	1CT:1CT	0°C to +70°C	1	1
749020111	1CT:1CT	0°C to +70°C	2	2

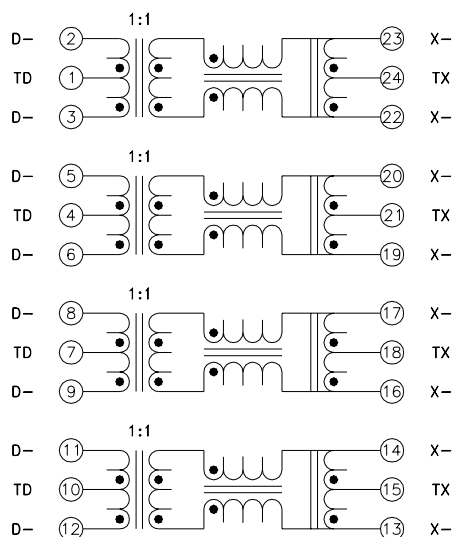

**Schematic 1**

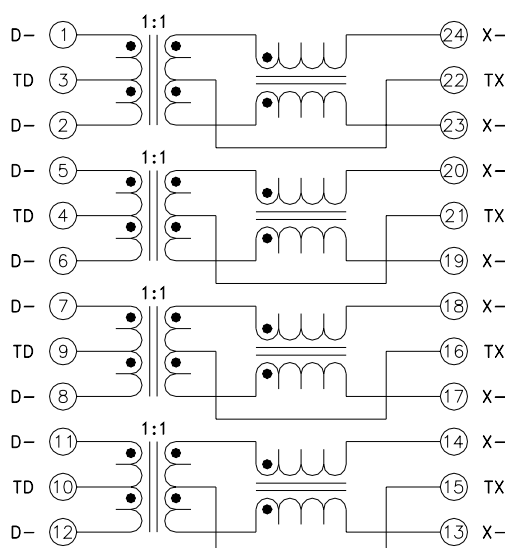

**Schematic 2**



# Discrete Single Port Gigabit EDSO-G24



LANDatacom

## Typical Common Electrical Characteristics<sup>1</sup>

Inductance	350uH Min.	0.1Vrms, 100kHz, 8mADC
Dielectric Rating	1500VAC	for 1 minute
Insertion Loss	-1.1dB max.	1MHz-100MHz
Return Loss	-16dB min.	1MHz-30MHz
	-14dB min.	40MHz
	-13dB min.	50MHz
	-12dB min.	60MHz-80MHz
Cross Talk	-43dB min.	30MHz
	-37dB min.	60MHz
	-33dB min.	100MHz
DCMR	-43dB min.	30MHz
	-37dB min.	60MHz
	-33dB min.	100MHz

## Features

- Meets IEEE 802.3 standard
- Surface mount
- Transfer mold package
- Optional pin-outs
- Industry standard footprint
- Optimum performance
- Cost Effective
- Both RoHS compliant and lead-terminal parts available

Note1: See specification sheet for actual electrical characteristics

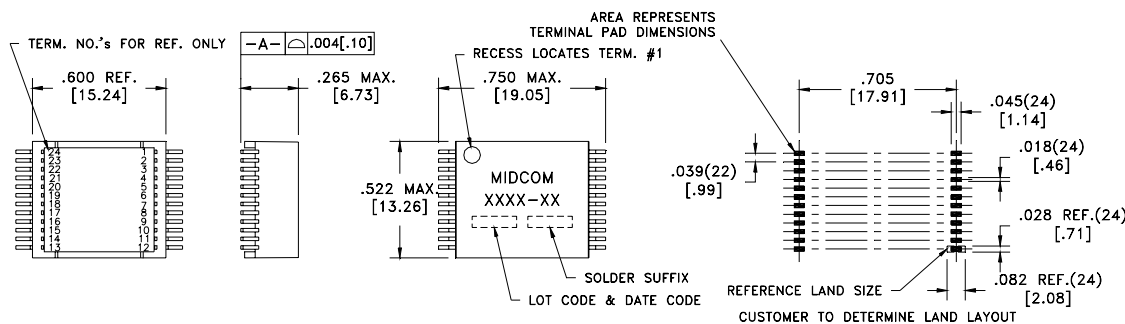

## AutoMDIX Operating

Part Number	Turns Ratio	Compatible	Temp. Range	Schematic
000-7347-30	1CT:1CT	Yes	0°C to +70°C	1
000-7330-30	1CT:1CT	Yes	-40°C to +85°C	2
000-7331-30	1CT:1CT	Yes	-40°C to +85°C	3

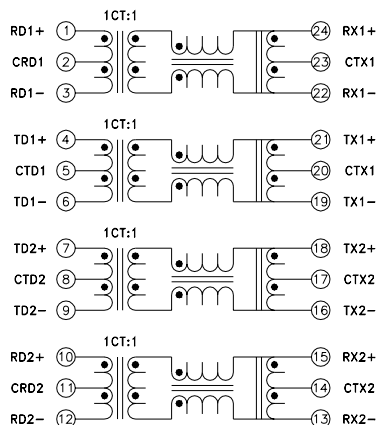

Schematic 1

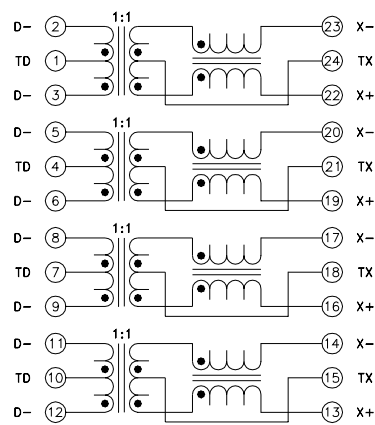

Schematic 2

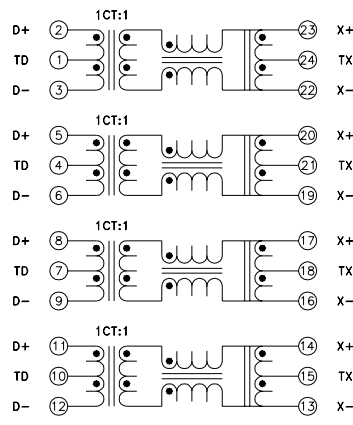

Schematic 3

5/01/08 Details subject to change. Contact your Midcom sales representative for additional information. Dimensions: in/mm. All tolerances are ± .010/0,25 and electrical specifications are @ 25°C unless otherwise specified.

# Discrete Single Port Gigabit PDFP-G24



LANDatacom

## Typical Common Electrical Characteristics<sup>1</sup>

Inductance	350uH Min.	0.1Vrms, 100kHz, 8mADC
Dielectric Rating	1500VAC	for 1 minute
Insertion Loss	-1.0dB max.	300kHz-125MHz
Return Loss	-18dB min.	500KHz-40MHz
	-15dB min.	40MHz-60MHz
	-12dB min.	60MHz-80MHz
	-10dB min.	80MHz-100MHz
Cross Talk	-35dB min.	300kHz-100MHz
Common Mode Rejection	-42dB min.	300kHz-32MHz
	-33dB min.	32MHz-100MHz

Note1: See specification sheet for electrical characteristic

## Features

- Meets IEEE 802.3 standard
- Surface mount
- Transfer mold package
- Optional pin-outs
- Industry standard footprint
- Optimum performance
- Cost Effective
- Both RoHS compliant and lead-terminal parts available

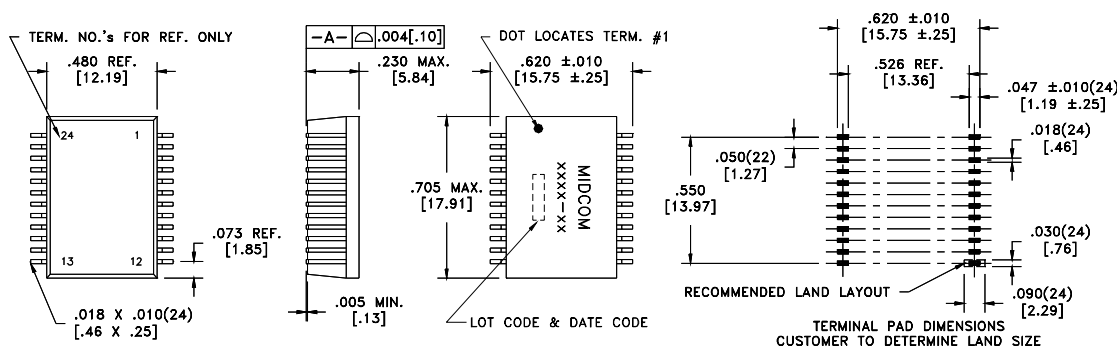

Part Number	Turns Ratio	AutoMDIX Compatible	Operating Temp. Range	Schematic
000-7093-37	1CT:1CT	Yes	-40°C to +85°C	1
000-7044-37	1CT:1CT	Yes	-40°C to +85°C	2
000-7367-37	1CT:1CT	Yes	0°C to +70°C	3

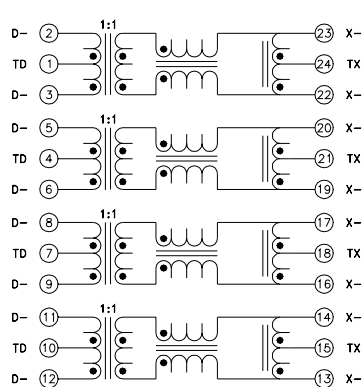

Schematic 1

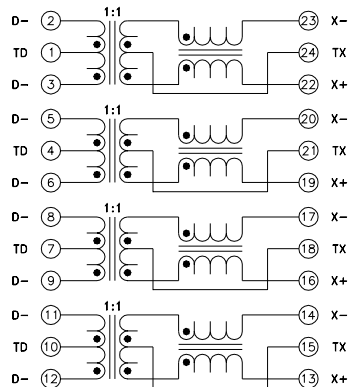

Schematic 2

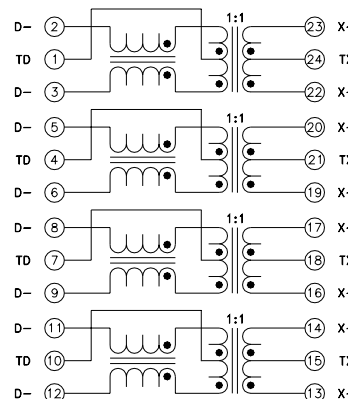

Schematic 3

Details subject to change. Contact your Midcom sales representative for additional information. Dimensions: in/mm. All tolerances are ± .010/0.25 and electrical specifications are @ 25°C unless otherwise specified.

# Discrete Dual Port Gigabit PDFP-G48

## Features

- Meets IEEE 802.3 standard
- Surface mount
- Optional pin-outs
- Industry standard connector footprint
- Optimum performance
- Cost Effective
- Both RoHS compliant and lead-terminal parts available

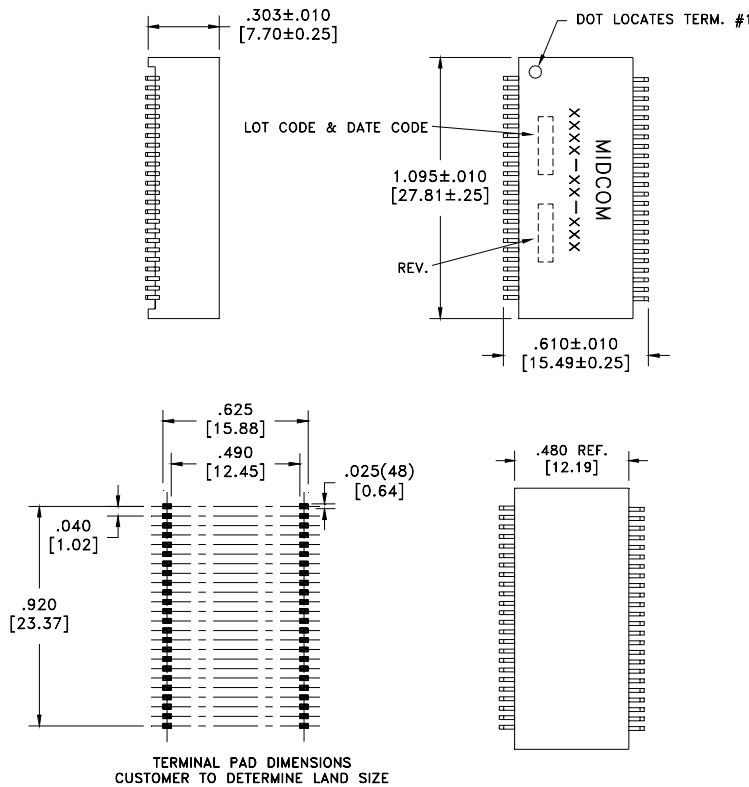

Part Number	Turns Ratio	AutoMDIX Compatible	Operating Temp. Range	Schematic
000-7375-30	1CT:1CT	Yes	-40°C to +85°C	1
000-7365-30	1CT:1CT	Yes	0°C to +70°C	2

### Typical Common Electrical Characteristics<sup>1</sup>

Inductance	350uH Min.	0.1Vrms, 100kHz, 8mADC
Dielectric Rating	1500VAC	for 1 minute
Insertion Loss	-1.0dB max.	300kHz-125MHz
Return Loss	-18dB min.	500KHz-40MHz
	-15dB min.	40MHz-60MHz
	-12dB min.	60MHz-80MHz
	-10dB min.	80MHz-100MHz
Cross Talk	-33dB min.	100kHz-100MHz
Common Mode Rejection	-30dB min.	100kHz-100MHz

Note 1: Electrical characteristics vary between part numbers, see specification sheets.

## Discrete Dual Port Gigabit PDFP-G48 Schematics

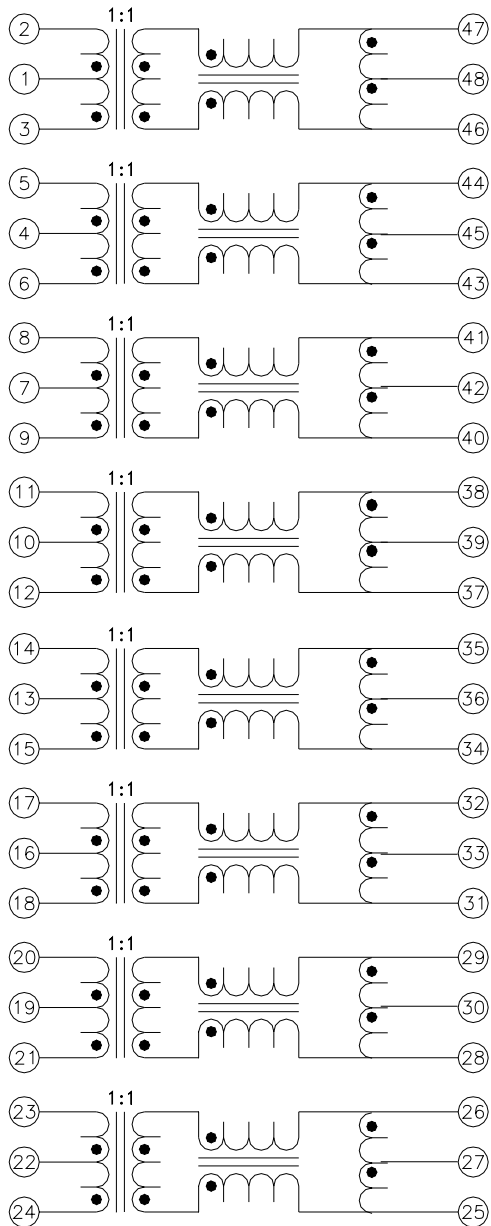

**Schematic 1**

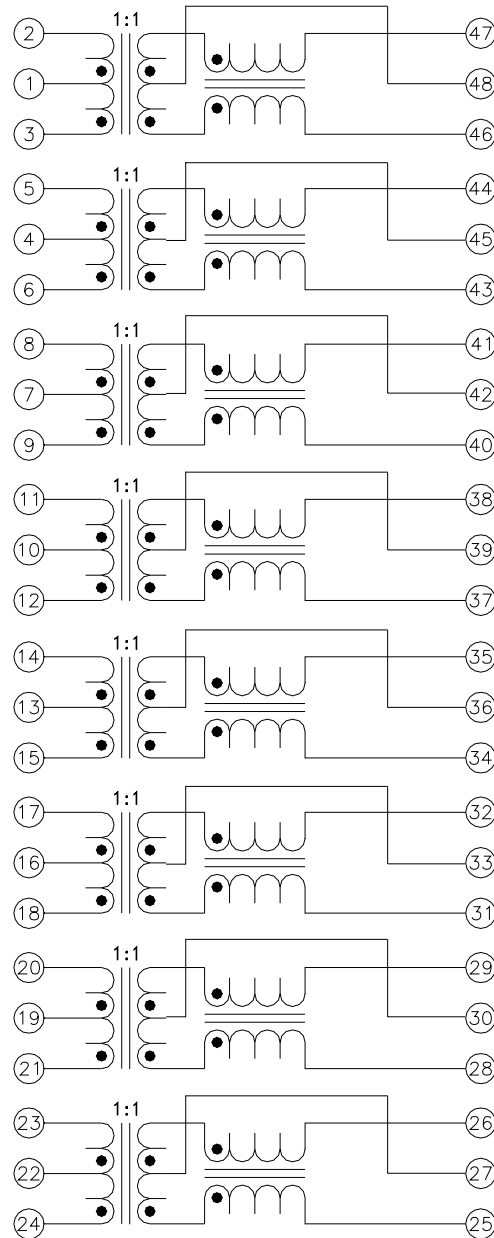

**Schematic 2**

# Discrete HPLN Module PDFP-G16

## Features

- Transfer molded package
- Surface mount
- Optional pin-outs
- Industry standard connector footprint
- Optimum performance
- Cost Effective
- Both RoHS compliant and lead-terminal parts available
- 2000VAC isolation for 2 seconds

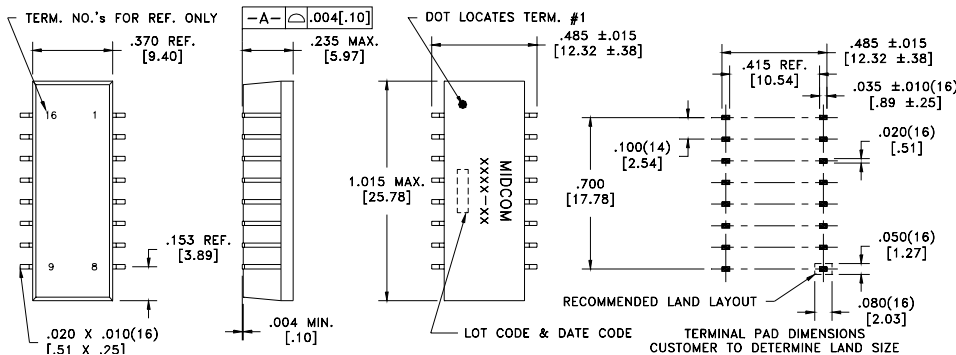
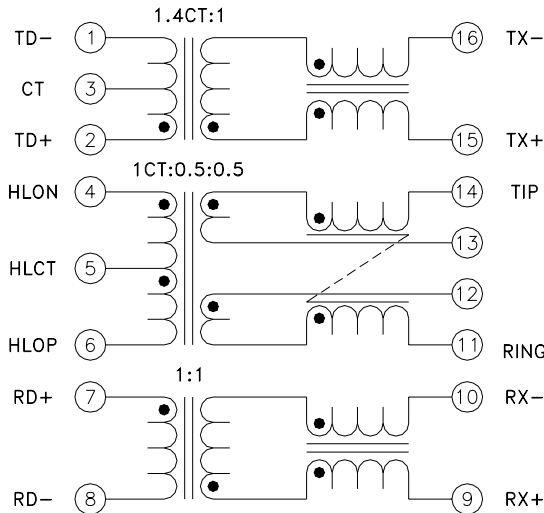

Part Number	Insertion Loss (1M-12MHz)	Return Loss (1M-12MHz)	Inductance	Leakage Inductance	Interwinding Capacitance	DC Resistance
000-7141-37	-1.0dB max.	-18dB min.	140µH min.	0.5µH max.	12pF max.	0.6Ω max.

5/01/08 Details subject to change. Contact your Midcom sales representative for additional information. Dimensions: in/mm. All tolerances are ± .010/0,25 and electrical specifications are @ 25°C unless otherwise specified.

## Discrete AUI Transformers PDSO-G16

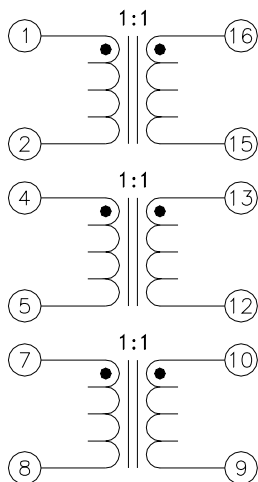

### Features

- Meets IEEE 802.3 standard
- Surface mount
- Transfer mold package
- Optional pin-outs
- Industry standard connector footprint
- Optimum performance
- Cost Effective
- Both RoHS compliant and lead-terminal parts available
- 1500VAC isolation for 1 minute

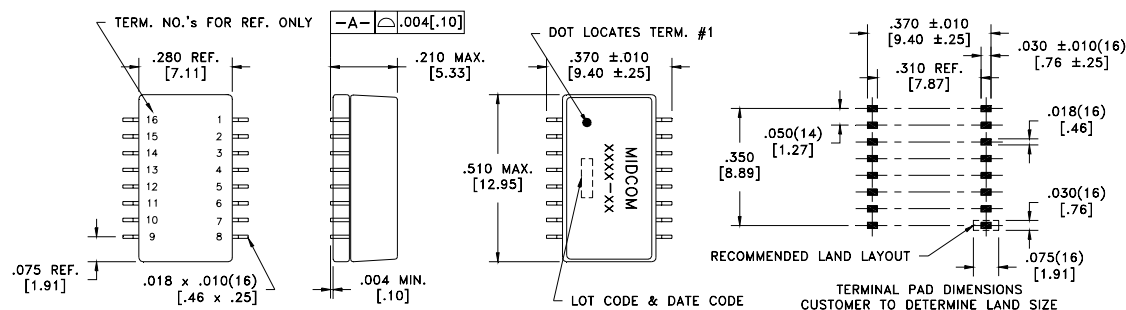

Part Number	Turns Ratio	Inductance	Leakage Inductance	Interwinding Capacitance	DC Resistance	Operating Temp. Range
000-5418-30	1:1	120-180µH min.	0.2µH max.	12pF max.	0.3Ω max.	0°C to +70°C
000-5421-30	1:1	60-90µH min.	0.2µH max.	7pF max.	0.3Ω max.	-40°C to +85°C
000-5366-30	1:1	80-120µH min.	0.2µH max.	9pF max.	0.3Ω max.	0°C to +70°C

Details subject to change. Contact your Midcom sales representative for additional information. Dimensions: in/mm. All tolerances are ± .010/0.25 and electrical specifications are @ 25°C unless otherwise specified.

## Discrete Fiber to Coax Transformer EDSO-G16

### Features

- Supports E4/STS-3/STM-1/OC-3 applications
- Surface mount
- Optional pin-outs
- Industry standard connector footprint
- Optimum performance
- Cost Effective
- Both RoHS compliant and lead-terminal parts available
- 1500VAC isolation for 1 minute

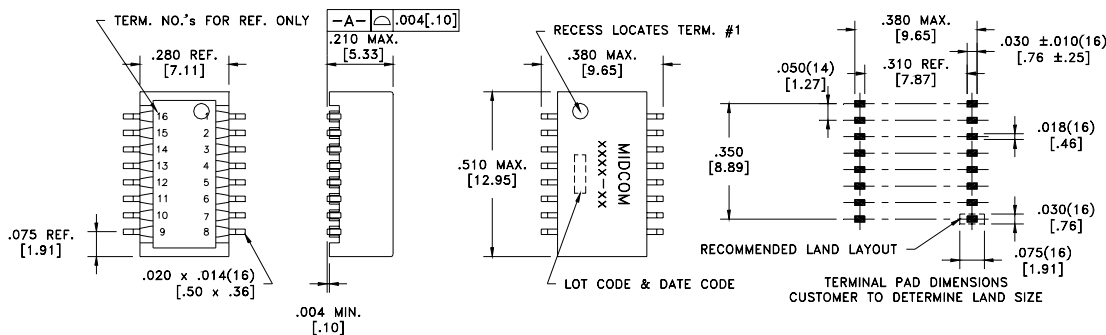
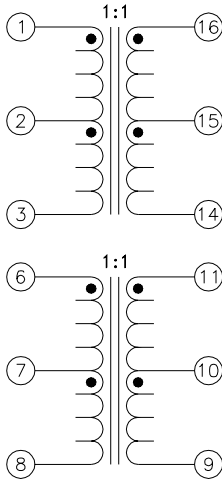

Part Number	Turns Ratio	Inductance	Leakage Inductance	Interwinding Capacitance	DC Resistance	Operating Temp. Range
000-7146-30	1CT:1CT	36μH min.	0.1μH max.	5pF max.	0.2Ω max.	0°C to +70°C

# Ethernet 10/100 Base-T

## IC Cross Reference



LANDatacom

IC Manufacturer	IC Number	Discreet P/N	Package Style	Integrated RJ45 P/N	Turns Ratio Tx Rx	Ports
<b>ADMtek</b>						
	ADM8515	000-7090-37R	PDSO-G16	MIC24xxx-xxxx	1:1 1:1	Single
	AN983B	000-6241-37R	PDFP-G16	MIC25xxx-xxxx	1:1 1:1	Single
<b>AMD</b>						
	AM79C830 (NetPHY-1)	000-6241-37R	PDFP-G16	MIC25xxx-xxxx	1:1 1:1	Single
		000-6181-37R	PDFP-G14		1:1 1:1	Single
		000-7159-30R	EDSO-G16		1:1 1:1	SOIC
	AM79C874	000-6241-37R	PDFP-G16	MIC25xxx-xxxx	1:1 1:1	Single
		000-6181-37R	PDFP-G14		1:1 1:1	Single
		000-7159-30R	EDSO-G16		1:1 1:1	SOIC
	AM79C874 (NetPHY-1LP)	000-6812-37R	PDFP-G16		1.25:1 1:1	Single
	AM79C973	000-7092-37R	PDSO-G16		1:1.4 1:1	Single
	AM79C875	000-6945-37R	PDFP-G40	1x4 MIC *Contact Us	1:1 1:1	Quad
	AM79C875 (NetPHY-4LP)	000-6931-37R	PDFP-G40	1x4 MIC *Contact Us	1:1 1:1	Quad
<b>Broadcom</b>						
	BCM5201	000-6241-37R	PDFP-G16	MIC25xxx-xxxx	1:1 1:1	Single
		000-6181-37R	PDFP-G14		1:1 1:1	Single
		000-7159-30R	EDSO-G16		1:1 1:1	SOIC
	BCM5221	000-7090-37R	PDSO-G16	MIC24xxx-xxxx	1:1 1:1	Single
		000-7218-35R	AEDFP-G16		1:1 1:1	PCMCIA
		000-7160-30R	EDSO-G16		1:1 1:1	SOIC
		000-7112-35R	AEDFP-G16		1:1 1:1	PCMCIA
	BCM5203, BCM5204	000-6945-37R	PDFP-G40	1x4 MIC *Contact Us	1:1 1:1	Quad
	BCM5205, BCM5208	000-6931-37R	PDFP-G40		1:1 1:1	Quad
	BCM5216, BCM5218					
	BCM5304, BCM5308					
	AC101	000-6241-37R	PDFP-G16	MIC25xxx-xxxx	1:1 1:1	Single
		000-6181-37R	PDFP-G14		1:1 1:1	Single
		000-7159-30R	EDSO-G16		1:1 1:1	SOIC
	AC104	000-6887-37R	PDFP-G40	1x4 MIC *Contact Us	1:1 1:1	Quad
	BCM5226, BCM5228	000-7120-37R	PDFP-G40	1x4 MIC *Contact Us	1:1 1:1	Quad
<b>Cirrus Logic</b>						
	CS8952	000-6241-37R	PDFP-G16	MIC25xxx-xxxx	1:1 1:1	Single
		000-6181-37R	PDFP-G14		1:1 1:1	Single
		000-7159-30R	PDSO-G16		1:1 1:1	SOIC
		000-6887-37R	PDFP-G40		1:1 1:1	Quad
<b>ICS</b>						
	ICS1893	000-7090-37R	PDSO-G16	MIC24xxx-xxxx	1:1 1:1	Single
<b>Intel</b>						
	S82555	000-6241-37R	PDFP-G16	MIC25xxx-xxxx	1:1 1:1	Single
	S82558	000-6181-37R	PDFP-G14		1:1 1:1	Single
	S82562	000-7159-30R	EDSO-G16		1:1 1:1	SOIC
		000-6886-37R	PDFP-G40		1:1 1:1	Quad
		000-6887-37R	PDFP-G40		1:1 1:1	Quad
<b>Intel/ Level One</b>						
	LXT970A	000-6241-37R	PDFP-G16	MIC25xxx-xxxx	1:1 1:1	Single
	LXT971	000-6181-37R	PDFP-G14	MIC24xxx-xxxx	1:1 1:1	Single
	LXT972	000-7090-37R	PDSO-G16		1:1 1:1	Single
	LXT973	000-7159-30R	EDSO-G16		1:1 1:1	SOIC
	LXT9761	000-7160-30R	EDSO-G16		1:1 1:1	SOIC
	LXT9781	000-7112-35R	AEDFP-G16		1:1 1:1	PCMCIA
		000-7218-35R	AEDFP-G16		1:1 1:1	PCMCIA
	LXT9762	000-6886-37R	PDFP-G40		1:1 1:1	Quad
	LXT9782	000-6887-37R	PDFP-G40		1:1 1:1	Quad
	LXT9784	000-7144-37R	PDFP-G40	1x4 MIC *Contact Us	1:1 1:1	Quad
	LXT980, LXT981, LXT982					
	LXT983, LXT974A, LXT95A					
	LXT976X, LXT978X	000-6932-37R	PDFP-G40		2:1 1:1	Quad
	LXT9785	000-7120-37R	PDFP-G40	1x4 MIC *Contact Us	1:1 1:1	Quad

Details subject to change. Contact your Midcom sales representative for additional information. Dimensions: in/mm. All tolerances are ± .010/0.25 and electrical specifications are @ 25°C unless otherwise specified.

5/01/08



# Ethernet 10/100 Base-T

## IC Cross Reference (continued)



**LANDatacom**

IC Manufacturer	IC Number	Discreet PN	Package Style	Integrated RJ45 PN	Turns Ratio Tx Rx	Ports
<b>LSI Logic</b>						
	L80223 ,L80225, L80227	000-7090-37R	PDSO-G16	MIC24xxx-xxxx	1:1 1:1	SOIC
<b>Lucent</b>						
	LUC3X04	000-6241-37R	PDFP-G16	MIC25xxx-xxxx	1:1 1:1	Single
	LUC3X14	000-6181-37R	PDFP-G14		1:1 1:1	Single
	LUC3C24	000-7159-30R	EDSO-G16		1:1 1:1	SOIC
	LUC3C51	000-6886-37R	PDFP-G40		1:1 1:1	Quad
		000-6887-37R	PDFP-G40		1:1 1:1	Quad
	LU6612	000-6241-37R	PDFP-G16	MIC25xxx-xxxx	1:1 1:1	Single
	LU1X54,LU2X54, LU3X54	000-6931-37R	PDFP-G40	1x4 MIC *Contact Us	1:1 1:1	Quad
<b>Microlinear</b>						
	ML6671	000-6120-37R	PDFP-G14		1:1 1:1	Single
<b>National Semi</b>						
	DP83843	000-6241-37R	PDFP-G16	MIC25xxx-xxxx	1:1 1:1	Single
	DP83815	000-6181-37R	PDFP-G14		1:1 1:1	Single
		000-7159-30R	EDSO-G16		1:1 1:1	SOIC
	DP83223	000-6887-37R	PDFP-G40	1x4 MIC *Contact Us	1:1 1:1	Quad
<b>Realtek</b>						
	RTL8139	000-6241-37R	PDFP-G16	MIC25xxx-xxxx	1:1 1:1	Single
	RTL8139C	000-6181-37R	PDFP-G14		1:1 1:1	Single
		000-7159-30R	PDSO-G16		1:1 1:1	SOIC
<b>SMSC</b>						
	LAN83C180	000-6241-37R	PDFP-G16	MIC25xxx-xxxx	1:1 1:1	Single
	LAN83C183	000-6181-37R	PDFP-G14	MIC24xxx-xxxx	1:1 1:1	Single
	LAN83C190	000-7090-37R	PDSO-G16		1:1 1:1	Single
		000-7159-30R	EDSO-G16		1:1 1:1	SOIC
		000-7218-35R	AEDFP-G16		1:1 1:1	PCMCIA
		000-7160-30R	EDSO-G16		1:1 1:1	SOIC
		000-7112-35R	AEDFP-G16		1:1 1:1	PCMCIA
<b>TDK</b>						
	7SC78Q2120	000-6241-37R	PDFP-G16	MIC25xxx-xxxx	1:1 1:1	Single
		000-6181-37R	PDFP-G14		1:1 1:1	Single
		000-6887-37R	PDFP-G40		1:1 1:1	Quad
	78Q2102/2121	000-6120-37R	PDFP-G14		1:1 1:1	Single
<b>Texas Instruments</b>						
	TNETE2101	000-6241-37R	PDFP-G16	MIC25xxx-xxxx	1:1 1:1	Single
	TNETE2104	000-6181-37R	PDFP-G14		1:1 1:1	Single
		000-6886-37R	PDFP-G40		1:1 1:1	Quad

# Ethernet 10 Base-T

## IC cross Reference

IC Manufacturer	Chipset	Discrete PN	Package	Turns Ratio		Ports
				Tx	Rx	
<b>AMD</b>						
	AM79C940/970A	000-5830-37R	PDFP-G16	1:1	1:1	Single
	Am79C984	000-6309-37R	PDFP-G40	1:1	1:1	Quad
	AM79C985					
	Am79C988					
	AM79C989					
<b>Crystal</b>						
	CS8900	000-6156-30R	PDSO-G16	1:1.4	1:1	Single
		000-7196-37R	PDSO-G16	1:2.5	1:1	Single
	CS8904	000-6961-37R	PDFP-G40	1:1.4	1:1	Quad
<b>Intel</b>						
	82503	000-5408-37R	PDFP-G16	1:1	1:1	Single
	82506					
	82595					
<b>Level One</b>						
	LXT901	000-6156-30R	PDSO-G16	1:1.4	1:1	Single
	IXT901A	000-6122-30R	PDSO-G16	1:1.4	1:1	Single
	LXT907					
	LXT905	000-5453-30R	PDSO-G16	1:2	1:1	Single
	LXT908					
	LXT914	000-6961-37R	PDFP-G40	1:1.4	1:1	Quad
	LXT915					
<b>Motorola</b>						
	MC68160	000-5408-37R	PDFP-G16	1:1	1:1	Single
<b>National Semi</b>						
	DP83907	000-5453-30R	PDSO-G16	1:2	1:1	Single
<b>Realteck</b>						
	RTL8301	000-5408-37R	PDFP-G16	1:1	1:1	Single
	RTL8019AS					
<b>SMSC</b>						
	LAN91C96	000-5408-37R	PDFP-G16	1:1	1:1	Single
	LAN91C96 (3.3V)					
	DP83951	000-6964-37R	PDFP-F40	1:2	1:1	Quad
<b>TDK</b>						
	78Q902	000-5408-37R	PDFP-G16	1:1	1:1	Single
<b>Texas Instruments</b>						
	TNETE2004	000-6961-37R	PDFP-G40	1:1.4	1:1	Quad

\* Contact us for integrated RJ45 (MIC) solutions.

## Gigabit Cross Reference

Midcom



LANDatacom

IC Manufacturer	IC Number	Part Number	Turns Ratio	CMC	Auto Xmr	Package Style	Ports
<b>Broadcom</b>							
	<b>BCM5400</b>	000-7044-37R	1:1	Y	N	PDFP-G24	Single
		000-7219-35R	1:1	Y	N	AEDFP-G16	1/2 PCMCIA
		000-7093-37R	1:1	Y	Y	PDFP-G24	Single
	<b>BCM5401</b>	000-7044-37R	1:1	Y	N	PDFP-G24	Single
		000-7219-35R	1:1	Y	N	AEDFP-G16	Single
		000-7093-37R	1:1	Y	Y	PDFP-G24	Single
	<b>BCM5411</b>	000-7093-37R	1:1	Y	Y	PDFP-G24	Single
<b>Level one</b>							
	<b>LXT1000</b>	000-7044-37R	1:1	Y	N	PDFP-G24	Single
		000-7219-35R	1:1	Y	N	AEDFP-G16	Single
		000-7093-37R	1:1	Y	Y	PDFP-G24	Single
<b>Marvell</b>							
	<b>88E1000/1000S</b>	000-7044-37R	1:1	Y	N	PDFP-G24	Single
		000-7219-35R	1:1	Y	N	AEDFP-G16	Single
		000-7219-37R	1:1	Y	N	PDFP-G24	Single
		000-7093-37R	1:1	Y	Y	AEDFP-G16	Single
	<b>88E1010/1010S</b>	000-7044-37R	1:1	Y	N	PDFP-G24	Single
		000-7219-35R	1:1	Y	N	AEDFP-G16	Single
		000-7093-37R	1:1	Y	Y	PDFP-G24	Single
	<b>88E1020/1020S</b>	000-7044-37R	1:1	Y	N	PDFP-G24	Single
		000-7219-35R	1:1	Y	N	AEDFP-G16	Single
		000-7093-37R	1:1	Y	Y	PDFP-G24	Single
<b>National</b>							
	<b>DP83861</b>	000-7093-37R	1:1	Y	Y	PDFP-G24	Single
	<b>DP83862</b>	000-7093-37R	1:1	Y	Y	PDFP-G24	Single
	<b>DP83891</b>	000-7093-37R	1:1	Y	Y	PDFP-G24	Single
<b>Lucent</b>							
	<b>LU8u31</b>	000-7093-37R	1:1	Y	Y	PDFP-G24	Single
	<b>LU8X32</b>	000-7093-37R	1:1	Y	Y	PDFP-G24	Single

\* Contact us for integrated RJ45 (MIC) solutions.

## AUI IC Cross Reference

IC Manufacturer	IC Number	Part Number	Package Style	Sty Ports
AMD	AM79C100	000-5421-30R	PDSO-G16	Single
Cypress	CS83C92	000-5421-30R	PDSO-G16	Single
Lucent	TS7241	000-5418-30R	PDSO-G16	Single
SMSC	LAN91C96	000-5366-30R	PDSO-G16	Single

## Fiber to Coax

Part Number	Package Style	Turns	Ports
000-7146-37R	PDSO-16	1:1	Dual

**10Base2.** A form of Ethernet and IEEE 802.3 network cabling using thin coaxial. It refers to 10Mbit/s speed Baseband transmission over 200 meters maximum length and is commonly known as Cheapernet or ThinNet.

**10Base5.** A form of Ethernet and IEEE 802.3 network cabling using thick coax. It refers to 10Mbit/s speed Baseband transmission and 500m maximum length and is commonly known as ThickNet.

**10Base-T.** A form of Ethernet and IEEE 802.3 network cabling using twisted pair cabling. It refers to 10Mbit/s speed Baseband transmission over twisted pair cable CAT3, CAT4 or CAT5 with a maximum segment length of 100m.

**100Base-T.** A form of Ethernet and IEEE 802.3 network cabling using twisted pair cabling. It refers to 100Mbit/s speed Baseband transmission over twisted pair cable. 100Base-TX is over 2 pairs of Cat 5 UTP, and 100Base-FX is over fiber.

**1000Base-T.** A form of Ethernet and IEEE 802.3 network cabling using twisted pair cabling. It refers to the 100BASE-T Ethernet network access method which operates at 1,000 Mbps or equivalently 1Gbps.

**Attenuation.** The decrease in magnitude of a wave as it travels through any transmitting medium, such as a transformer or a filter. Attenuation is measured as a ratio or as the logarithm of a ration (Decibel dB).

**AUI.** Auxillary Unit Interconnect, a standard using DB-15 plugs to connect Ethernet transceivers to controllers.

**Autotransformer.** Is a transformer that has a single winding with a tap such that a step up or a step down voltage can be obtained. The autotransformer with the tap at the center is commonly used in 100Mbps magnetic to provide the balance for the devices.

**Bandwidth.** The range of frequencies a transmission line or channel can carry; the greater the bandwidth, the greater the information - carrying capacity of a channel. For a digital channel this is defined in bit/s. For an analog channel it is dependent on the type and method of modulation used to encode the data.

**Category 3 cable (CAT3).** Standard for UTP voice grade cabling specified by the EIA/TIA 568 standard for use at speeds up to 10Mbit/s including 10BaseT Ethernet.

**Category 4 cable (CAT4).** Cabling standard specified by EIA/TIA 568 for use at speeds up to 20Mbit/s including 16Mbit/s Token Ring.

**Category 5 cable (CAT5).** Cabling standard specified by EIA/TIA 568 for use for speeds up to 1000Mbit/s including FDDI (TP-PMD), 100BaseT and 1000BaseT.

**Common mode Choke.** Another term for an inductor which is intended to filter or choke out common mode signals.

**Crosstalk.** A type of interference caused by audio frequencies from one line being coupled into adjacent lines. The term is loosely used also to include coupling at higher frequencies. Measured in dB. A higher ratio is better.

**CMRR (Common Mode Rejection Ratio).** It measures the ability of a device in reducing common-mode noise.

**CSMA/CD. Carrier Sense Multiple Access with Collision Detection.** The access method used by local area networking technologies such as Ethernet.

**C<sub>ww</sub>:** is the interwinding or coupling capacitance between primary and secondary of the transformer. This capacitance impacts the high-frequency roll-off of the transformer. The higher the capacitance is, the lower the cutoff frequency will become. This parameter will affect the common mode noise rejection as well.

**DCR (DC Resistance).** It refers to the wire resistance of the winding, the thicker this wire, the lesser the resistance and have a little influence on the insertion loss and return loss of the transformer.

**Decibel (dB).** The standard unit for expressing relative power levels. Decibels indicate the ratio of power output to power input  $\text{dB} = 10 \log_{10} (P_1/P_2)$ .

**EMI (Electromagnetic Interference).** The electronic "noise" that cause distortion signal and create some errors that can corrupt data.

**Ethernet.** The most widely LAN transmission network. Based on a bus network topology, it runs at a maximum 1000Mbit/s and adopts CSMA/CD techniques transmission over conventional co-axial cable, thin wire co-axial cable and unshielded twisted pair cabling. A fiber-optic implementation has also been defined. Originally developed by Xerox, Intel and Dec, and latter standardized by the IEEE as the IEEE 802.3 standard. This has several implementations - 10Base5 for use over conventional co-axial cable, 10/100/1000BaseF for use over optic fiber, 10/100/1000BaseT, for use over Unshielded Twisted Pair (UTP) cabling.

**Fast Ethernet.** Proposed 100Mbit/s technology for workstation LANs from the Fast Ethernet Alliance. It has been adopted by the IEEE as the basis for the 100BaseT Ethernet standard.

**FCC (Federal Communications Commission)** US regulatory and approvals agency.

**Filter.** May consist of inductors, capacitors, and resistors. Its role is to provide signal conditioning and wave shaping, let the wanted signal going through and reject unwanted signal.

## Glossary of Terms (continued)



LANDatacom

**HPNA (Home Phone Networking Alliance).** is an association of industry-leading companies working together to promote the network technology that connects peripheral devices in the home using the existing telephone line.

**IEEE. Institute of Electrical and Electronics Engineers.** A group of experts that establishes electrical specification standards for electrical devices.

**IEEE 802.3** The IEEE standardization of Ethernet. A Physical Layer definition that includes specification for physical cabling plus the method of transmitting data and controlling access to the cable. It uses the CSMA/CD access method on a bus topology LAN.

**Isolation:** The electrical separation between two circuits, or circuit elements

**Isolation Voltage:** The maximum ac or dc specified voltage that may be continuously applied between isolated circuits.

**Insertion Loss.** is a comparison of the load power available with the transformer/filter in the circuit to the load power with the transformer/filter not in the circuit.

**Leakage Inductance(LL).** In a transformer or choke, the flux of the primary does not link to the secondary will generate the leakage flux. The greater this leakage flux, the greater the leakage inductance. The leakage inductance is the inductance measured at one winding with all other windings short circuited. It has an effect on the bandwidth of the transformer.

**Local Area Network (LAN).** A data network intended to serve a campus area. It connects two or more computers in a workgroup, department or building so those computers can exchange data via cables or broadcast devices.

**MDI (Medium Dependent Interface).** The mechanical and electrical interface between the trunk cable medium and the MAU.

**MDIX (Medium Dependent Interface Cross-over).** The mechanical and electrical interface that enables like devices to connect, using different pin-outs, avoiding conflicts that occur when receiving and transmitting packets use the same pin-out.

**OCL (Open Circuit Inductance).** Refer to the primary inductance, it impacts the low frequency roll off of the transformer.

**Primary Winding.** The coil winding connected to the input power available.

**PHY (Physical Layers Device).** Define hardware interfaces and access methods. It can operate at speed of 10/100/1000Mbps.

**PCMCIA (Personal Computer Memory Card International Association).** These term refers to the small credit card sized cards that uses on a portable computer.<sup>2</sup>

**Return loss** is the ratio, expressed in decibels, of the fractional amount of signal reflection caused by an impedance mismatch (eg: at the input to a transformer with respect to its source impedance).

**RJ-45 (Register Jack-45).** An eight-wire connector used commonly to connect computers onto a local area network especially Ethernets.

**RJ-11 (Registered Jack-11).** A four-wire connector used commonly to connect almost all phones, faxes, and modems to the wall plug for telephone service.

**Secondary Winding.** The coil winding supplying the load.

**UTP (Unshielded Twisted Pair).** A cable that contains a pair of twisted pair wires with no shield. This is the type of wiring used in 10/100/1000Base-T.

**VoIP (Voice over Internet Protocol).** A method of sending voice over a Internet Protocol such as TCP/IP.



Package Style EDFP-G16



LANDatacom

EDFP-G16

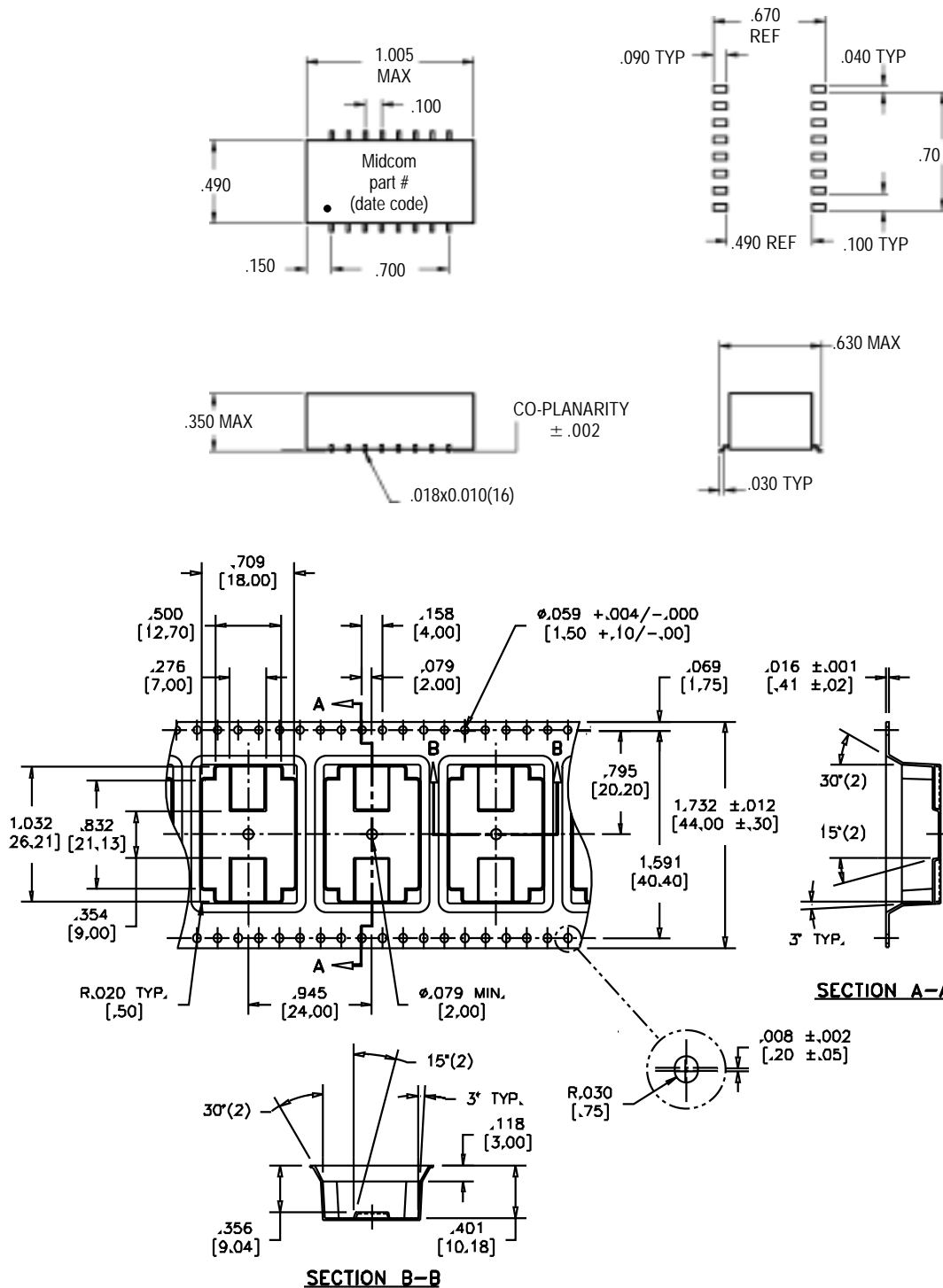

5/01/08 Details subject to change. Contact your Midcom sales representative for additional information. Dimensions: in/mm. All tolerances are ±.010/0,25 and electrical specifications are @ 25°C unless otherwise specified.

Package Style EDSO-G16



LANDatacom

EDSO-G16

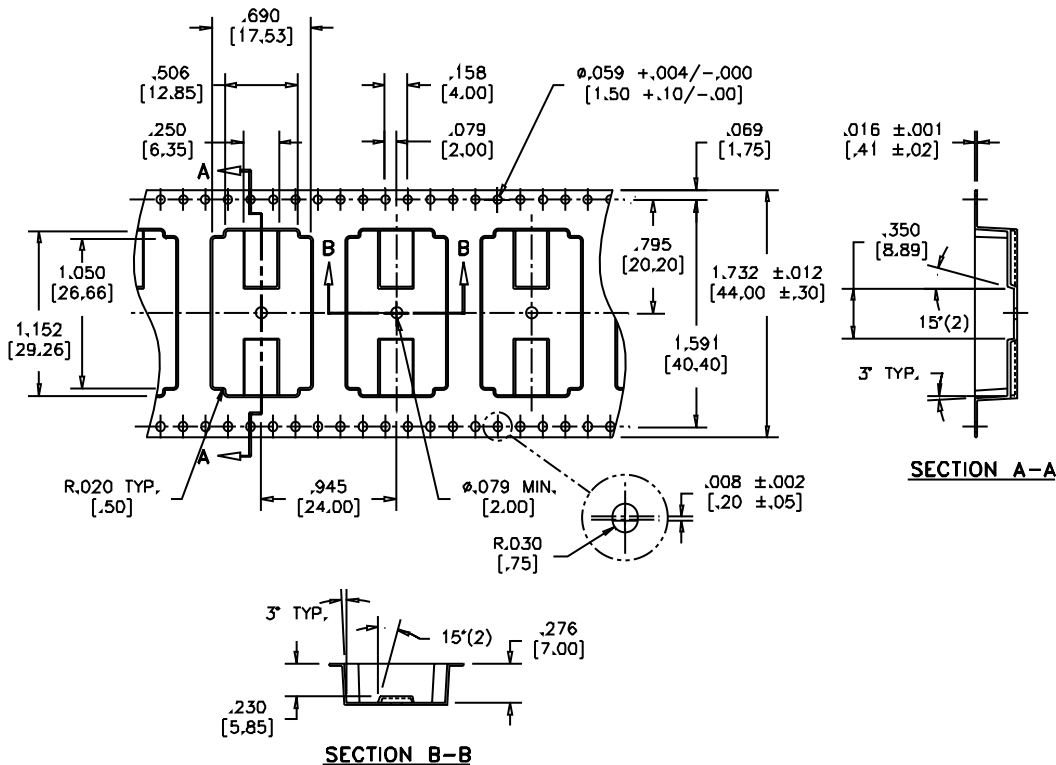
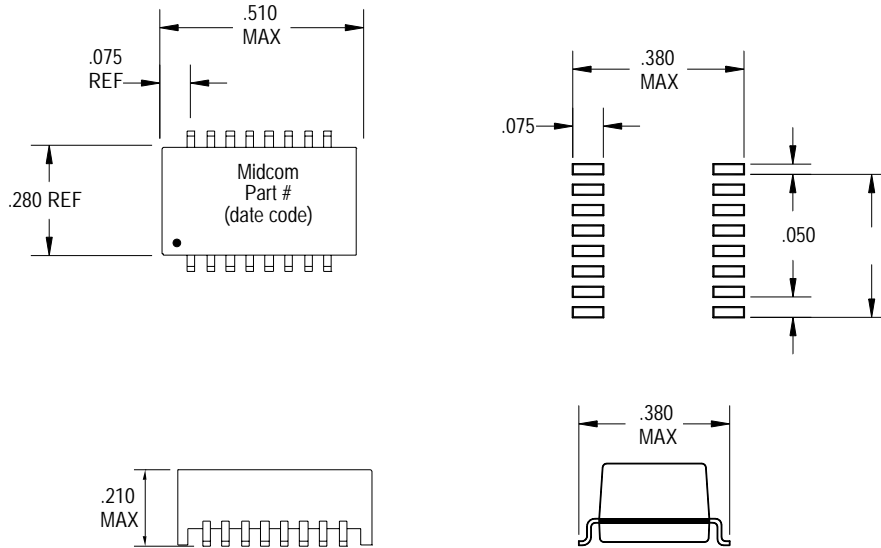

Details subject to change. Contact your Midcom sales representative for additional information. Dimensions: in/mm. All tolerances are  $\pm .010/0,25$  and electrical specifications are @ 25°C unless otherwise specified.

5/01/08

Package Style PDFP-G16



LANDatacom

PDFP-G16

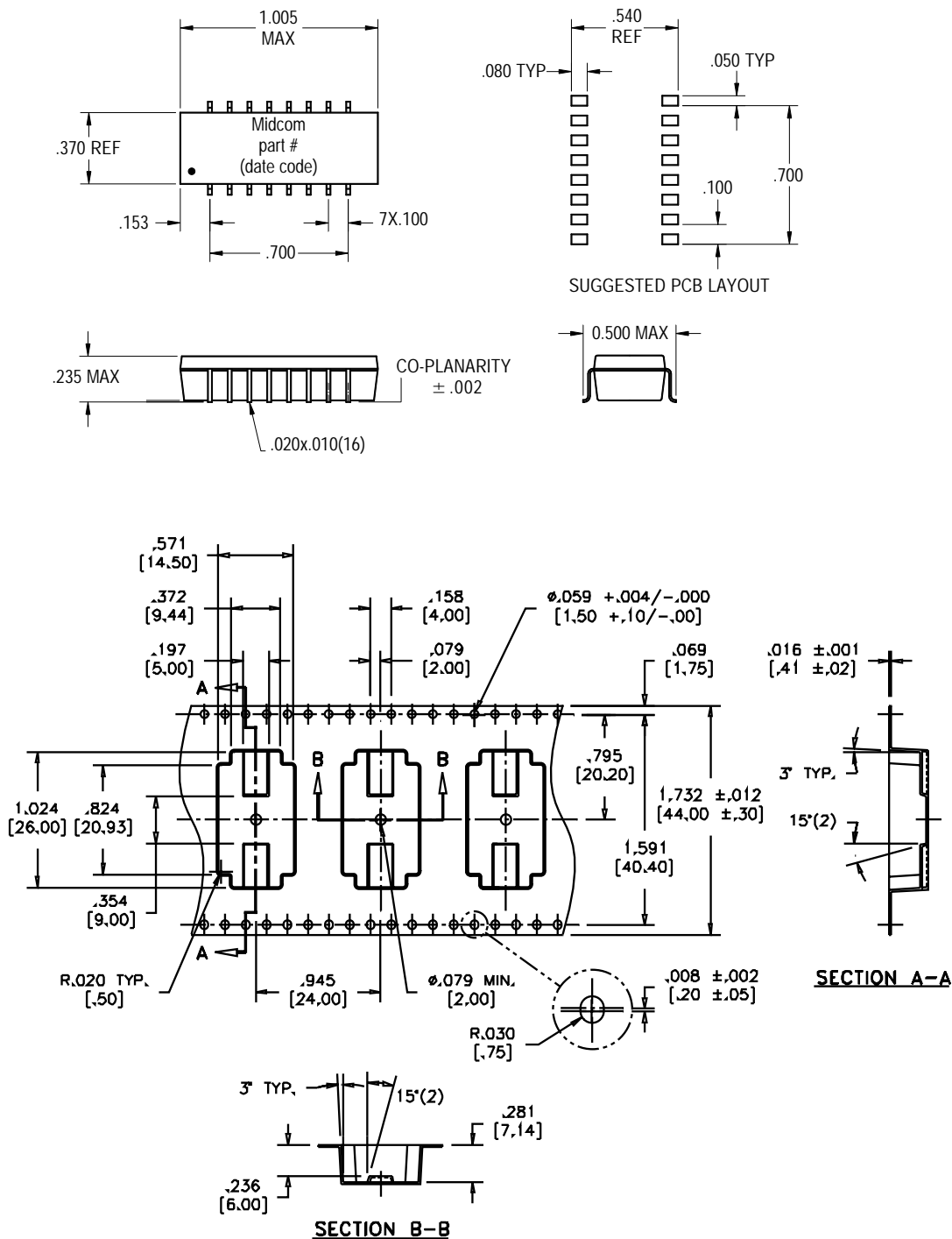

5/01/08 Details subject to change. Contact your Midcom sales representative for additional information. Dimensions: in/mm. All tolerances are ±.010/0,25 and electrical specifications are @ 25°C unless otherwise specified.

PDFP-G24

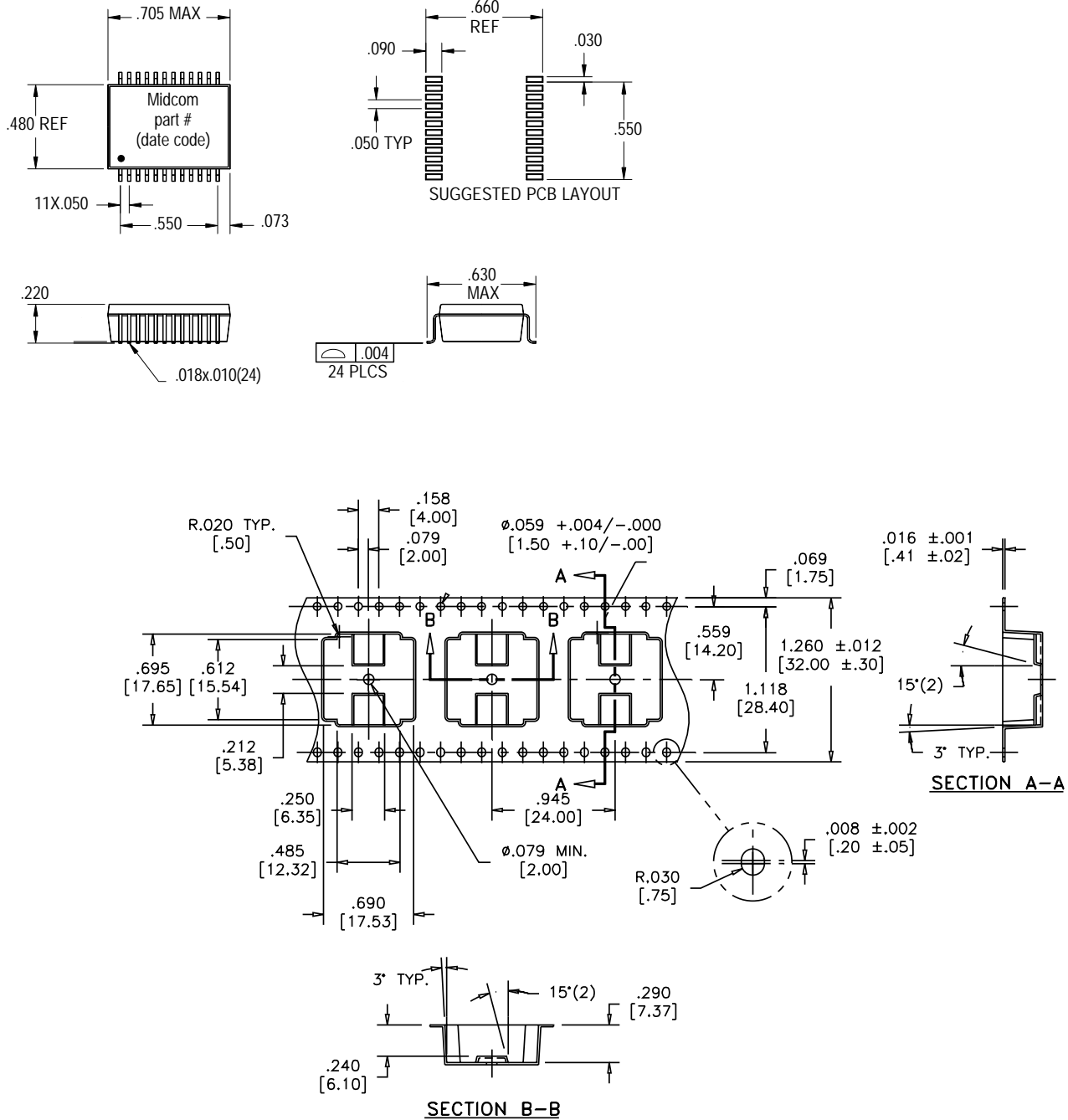

Details subject to change. Contact your Midcom sales representative for additional information. Dimensions: in/mm. All tolerances are ± .010/0.25 and electrical specifications are @ 25°C unless otherwise specified.

Package Style EDFP-G20



LANDatacom

EDFP-G20

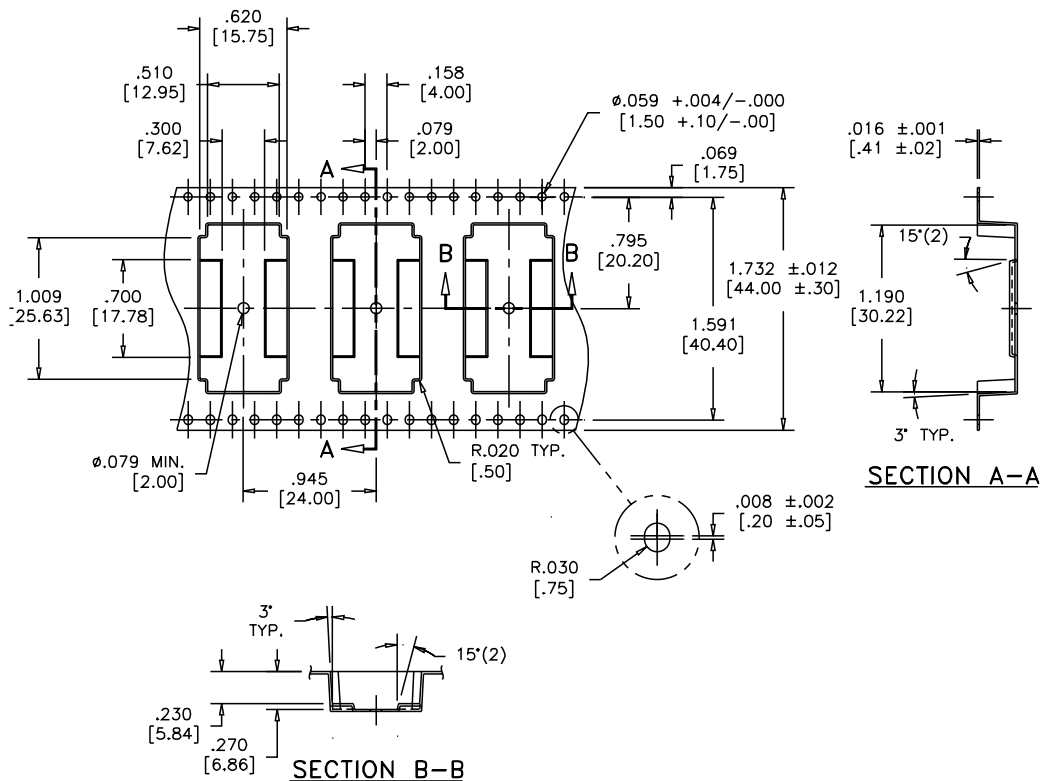
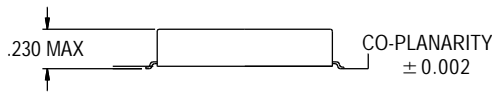
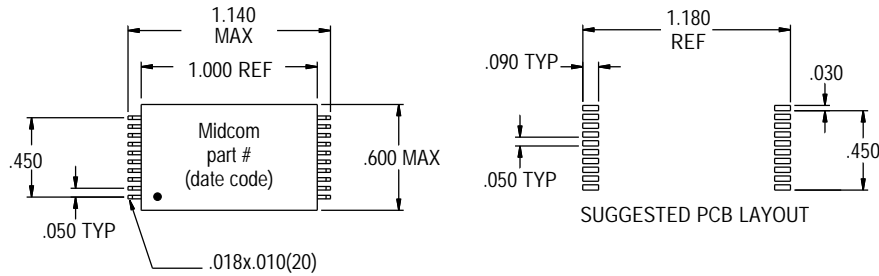

5/01/08 Details subject to change. Contact your Midcom sales representative for additional information. Dimensions: in/mm. All tolerances are ± .010/0,25 and electrical specifications are @ 25°C unless otherwise specified.

AEDFP-G16

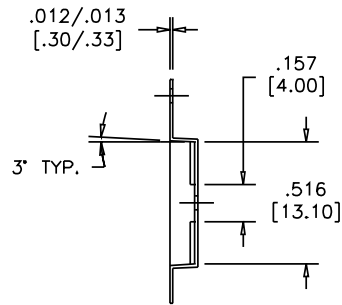
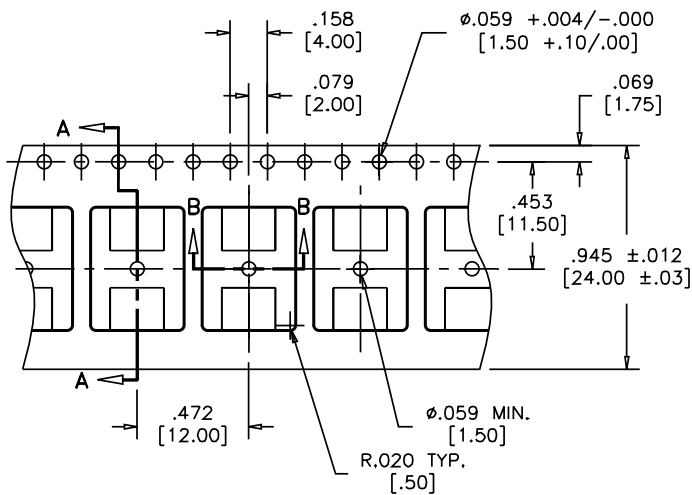
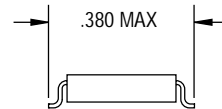
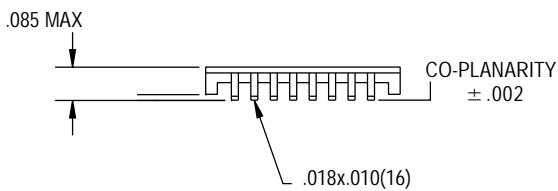
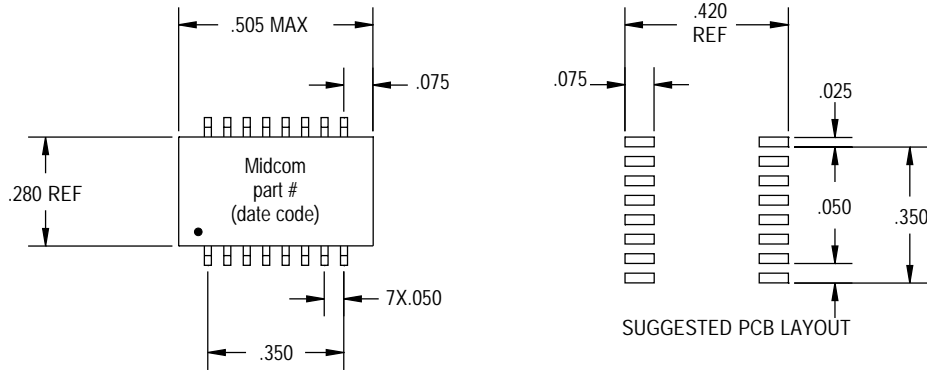

SECTION A-A

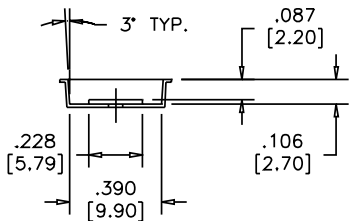

SECTION B-B

Details subject to change. Contact your Midcom sales representative for additional information. Dimensions: in/mm. All tolerances are ± .010/0,25 and electrical specifications are @ 25°C unless otherwise specified.

Package Style PDFP-G40



LANDatacom

PDFP-G40

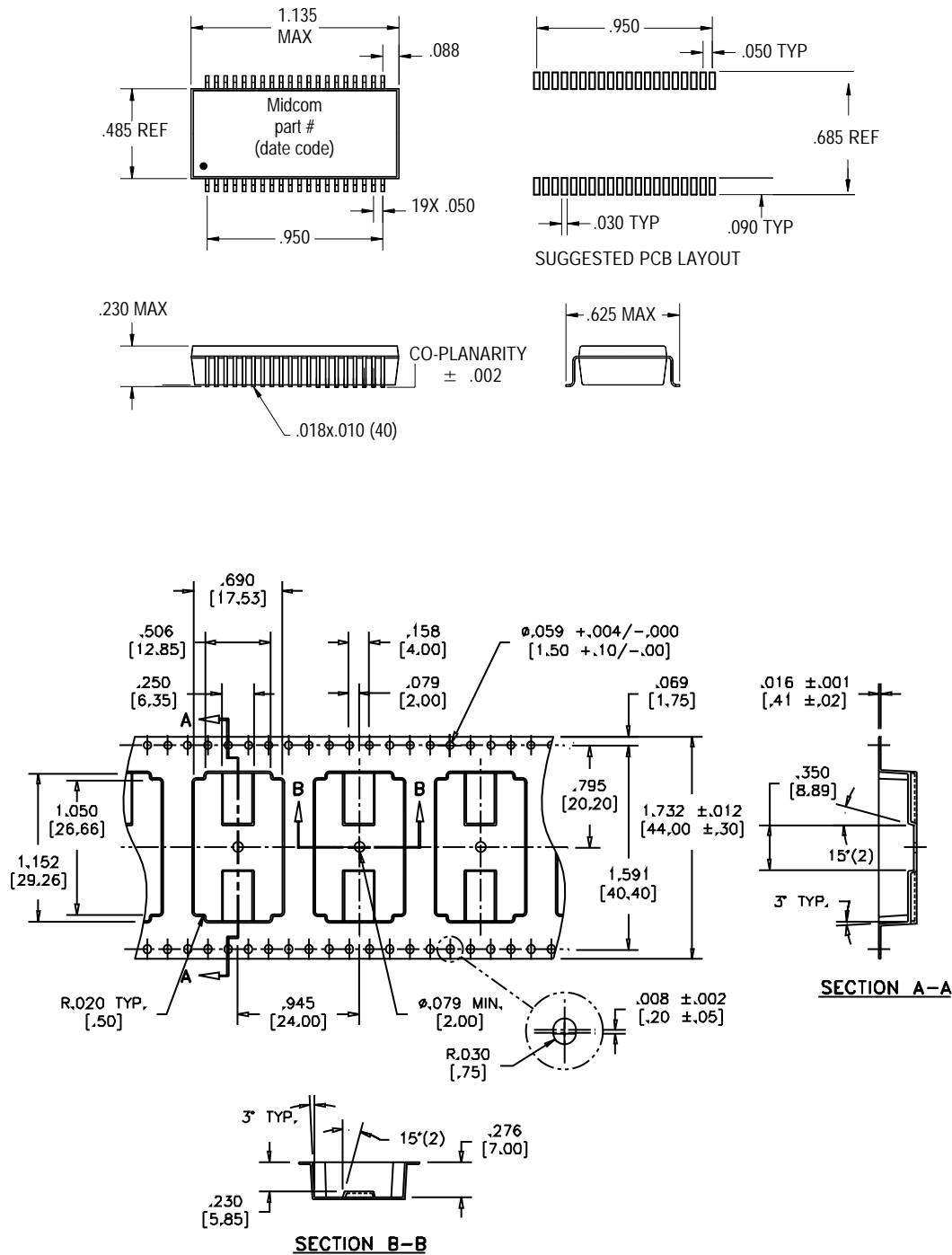

5/01/08 Details subject to change. Contact your Midcom sales representative for additional information. Dimensions: in/mm. All tolerances are ± .010/0,25 and electrical specifications are @ 25°C unless otherwise specified.

PDSO-G16

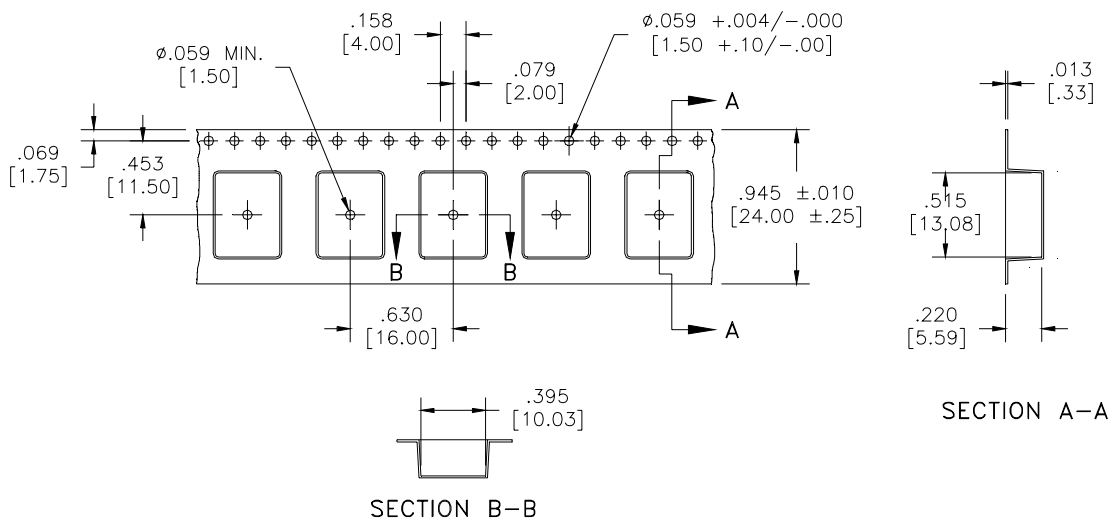
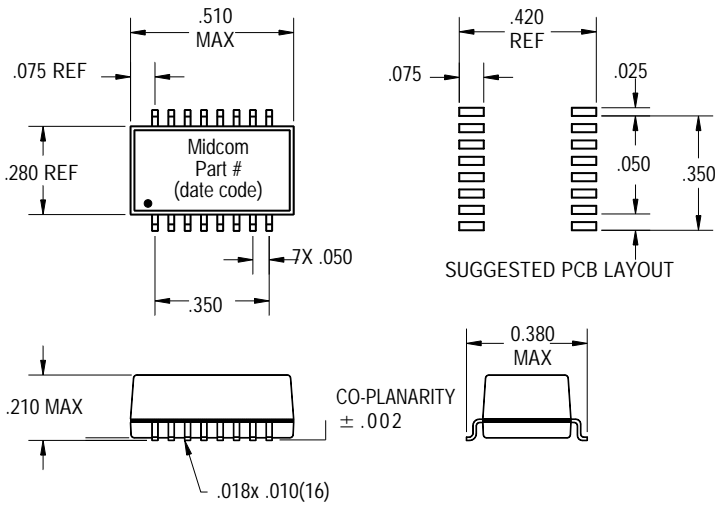

Details subject to change. Contact your Midcom sales representative for additional information. Dimensions: in/mm. All tolerances are ± .010/0.25 and electrical specifications are @ 25°C unless otherwise specified.



Package Style PDFP-G14



LANDatacom

PDFP-G14

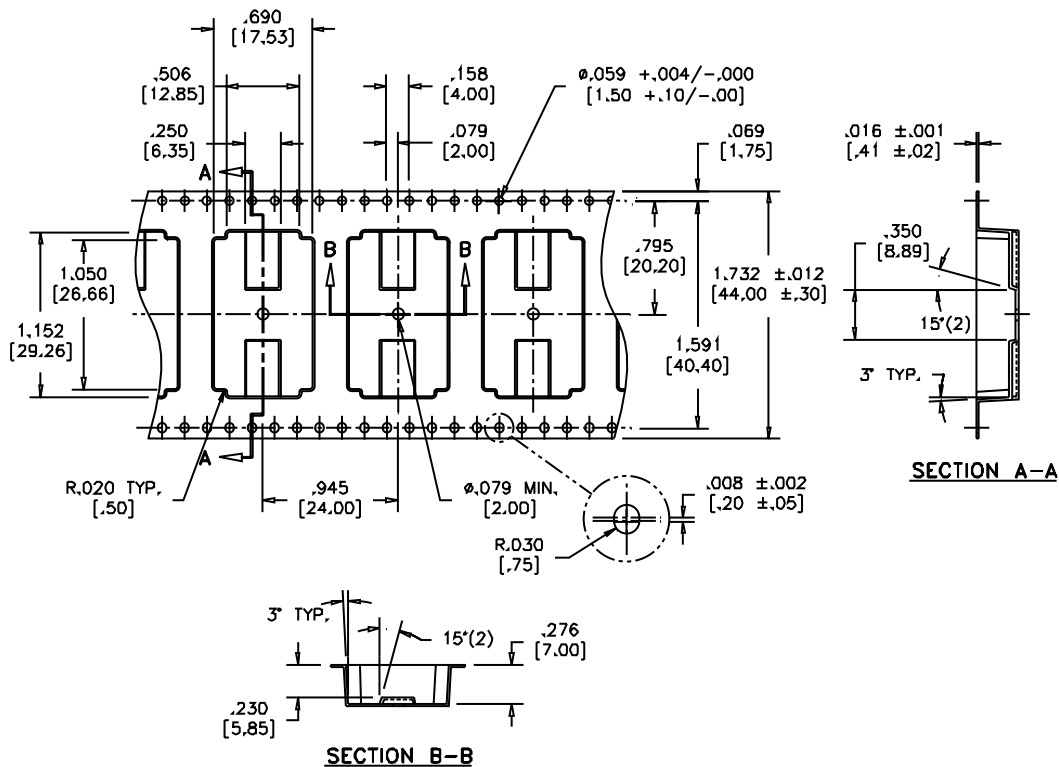
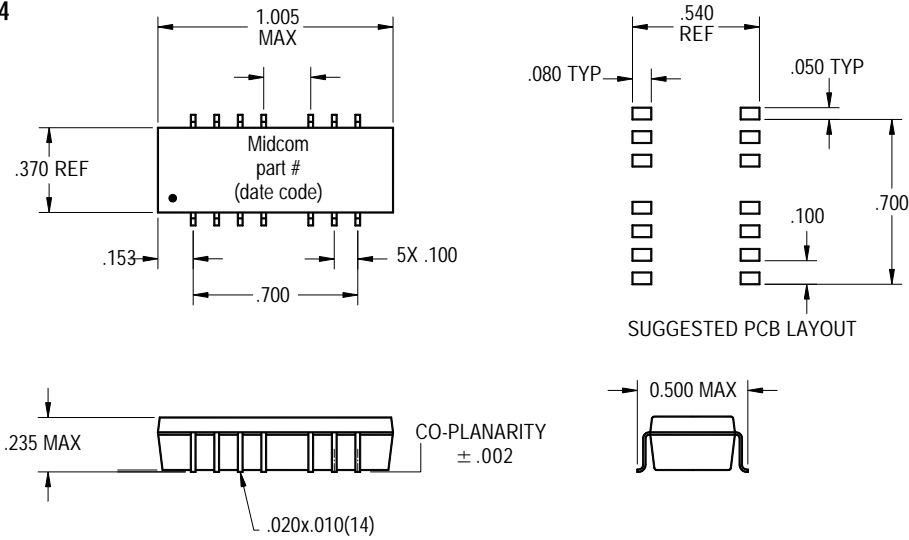

5/01/08 Details subject to change. Contact your Midcom sales representative for additional information. Dimensions: in/mm. All tolerances are ±.010/0.25 and electrical specifications are @ 25°C unless otherwise specified.

## SOLDERING

### TYPICAL IR REFLOW PROFILE

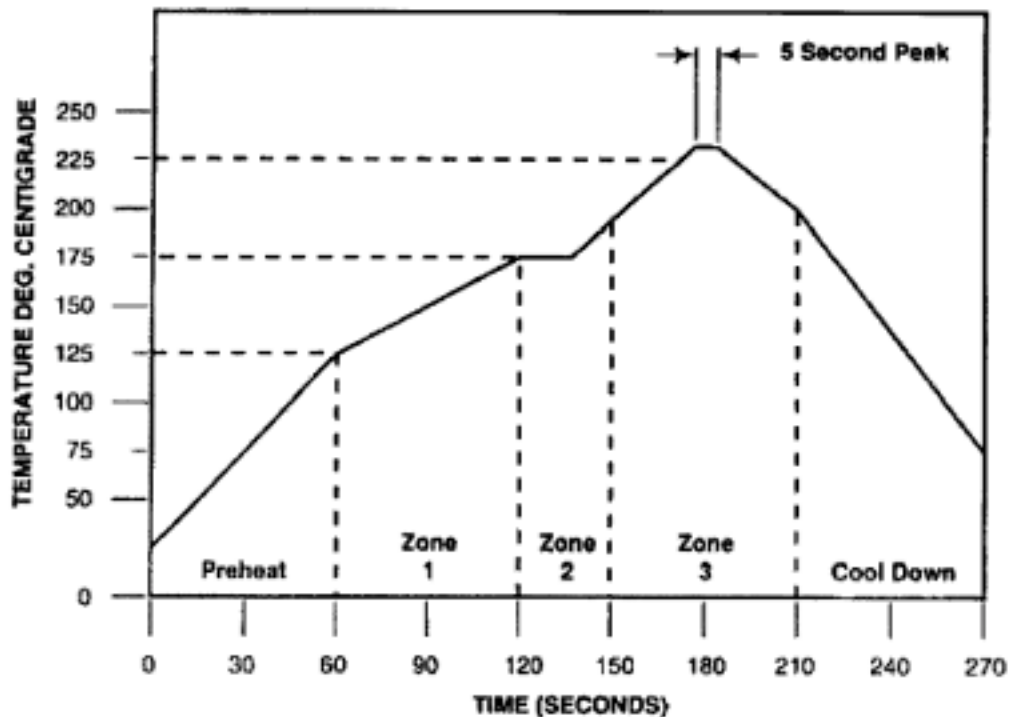

As a general rule for reflow soldering:

1. Preheat the components and the board to within 100°C of the soldering temperature for a minimum of 60 seconds. This ramping should not exceed 1 1/2° to 2 1/2°C per second.
2. Reflow soldering temperature should not exceed +230°C with a maximum time of 20 seconds.
3. In all cases, gradual cooling to room temperature is recommended.

Due to the variability in ovens and actual board assemblies, each PCB should be tested for component compatibility.

LAN Datacom  
Transformer Design Inquiry



Please complete this form and mail or fax it to Würth Electronics Midcom. You need only include the specifications you require.

**Company Information**

Company \_\_\_\_\_ Current Würth Electronics Midcom Customer?  Yes  No  
 Name \_\_\_\_\_ Sales Contact \_\_\_\_\_  
 Address \_\_\_\_\_ Phone \_\_\_\_\_ Fax \_\_\_\_\_  
 City \_\_\_\_\_ E-mail \_\_\_\_\_  
 State/Province \_\_\_\_\_ Postal Code \_\_\_\_\_ Samples Needed \_\_\_\_\_ Date Required \_\_\_\_\_  
 Customer Number \_\_\_\_\_ Mass Production Date \_\_\_\_\_

**Application**

If product safety is an issue, please contact us immediately for technical consultation. Our products are not designed for aviation, medical, automotive or life supporting devices. Such applications require our written approval prior to use.

IC Manufacturer \_\_\_\_\_ IC Number/Name \_\_\_\_\_  
 10Mbps  10/100Mbps  1000Mbps  HPLN  
 AUI  MDIX  PoE (VoIP)  Other \_\_\_\_\_

**Specifications – Note applicable frequency range and drive levels**

Turns Ratio \_\_\_\_\_ Inductance (uH) \_\_\_\_\_ with mADC \_\_\_\_\_  
 Insertion Loss (dB max.) \_\_\_\_\_ Return Loss (dB min.) \_\_\_\_\_  
 Common Mode Rejection (dB min.) \_\_\_\_\_ Crosstalk (dB min.) \_\_\_\_\_  
 Package Style \_\_\_\_\_  SMD  TH Max. Size: L \_\_\_\_\_ W \_\_\_\_\_ H \_\_\_\_\_  in  mm  
 Integrated RJ45:  SMD  TH:  TAB-UP  TAB-DOWN  EMI Shield Tabs  
 1x1  1x4:  1xN \_\_\_\_\_  LEDS Right Color \_\_\_\_\_ Left Color \_\_\_\_\_  
 2x1  2x4:  2xN \_\_\_\_\_ Temperature Range \_\_\_\_\_  
 Cross Reference Manufacturer \_\_\_\_\_ Cross Reference Part Number \_\_\_\_\_

**Agency Requirements**

Regulatory Agencies:  FCC  IEC60950  BABT  Austel  Other \_\_\_\_\_  
 Insulation Requirements:  Functional  Basic  Supplementary  Reinforced  
 Dielectric Withstand Voltage \_\_\_\_\_ Operating Voltage \_\_\_\_\_

**General**

Target Price \_\_\_\_\_ at quantity \_\_\_\_\_ Attach additional notes and requirements as necessary.

Details subject to change. Contact Würth Electronics Midcom for additional information. Dimensions in/mm. All tolerances are ±.010/.25 and electrical specifications are @25°C unless specified otherwise.