

High Voltage Contactors

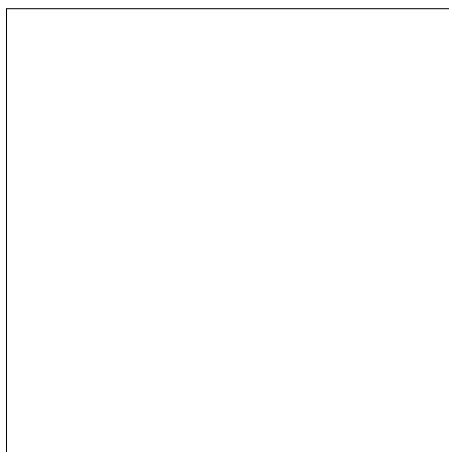
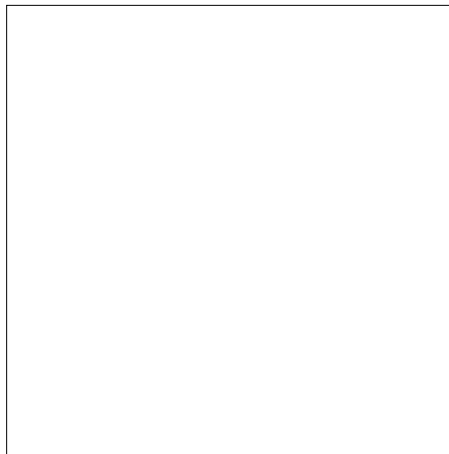

F 170e

Contents

	Page
1.0. Application	3
2.0. Power Rating	3
3.0. Device Data	4
3.1. Electronic Contactor Type ZH 767E / 767F	4
3.2. Contactor Type ZH 829	5
3.3. Contactor ZH 715 / 815	6
3.4. Contactor ZH 500 / 800 / 801	7
3.5. Contactor S 195 BE	8
4.0. Ordering Information	9

DC and AC Contactors for up to 4 kV

1.0. Application

The devices described in this catalog are designed for applications in rail vehicles. They are rated per IEC 77 (UIC 616). Typically they are used in heating ventilation, AC and lighting systems, in electronic converters and electric traction equipment etc.

Over 70 years of experience and successful applications world-wide guarantee competent and effective product support. Our ISO 9001 certification also reflects the high quality level of our products.

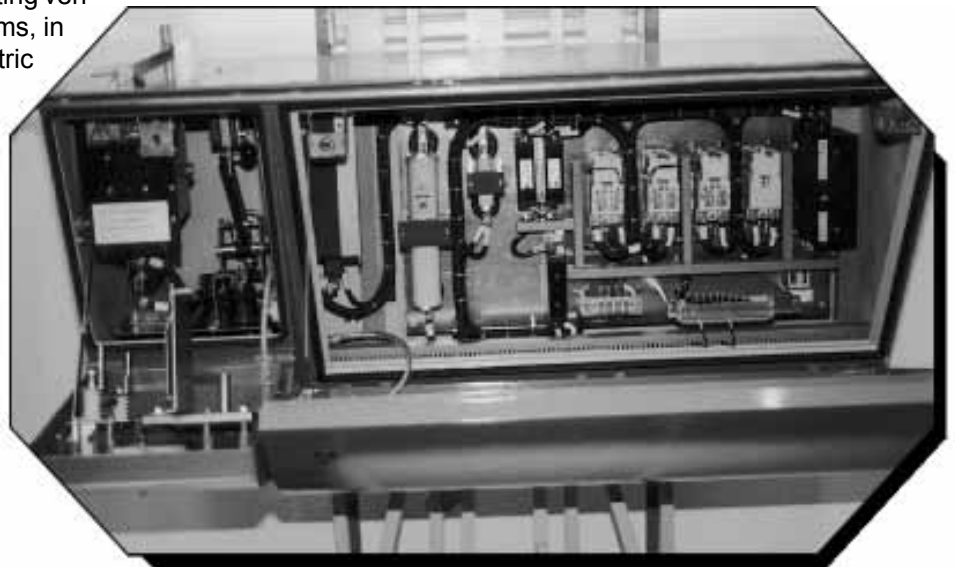

High voltage enclosure for ICE II with contactors S 195 BE and ZH 767

2.0. Power Rating

Contactors up to 100 kW switching capacity can be supplied for all internationally used catenary supply voltages:

1000V AC 16²/₃ Hz

1500V AC 50 Hz

1500V DC

3000V DC and up to 4000V DC.

Contactors for DC voltages from 600V to 1000V are described in catalog F 215e.

	1000 V AC	1500 V AC	1500 V DC	3000 V DC to 4000 V DC
ZH 767	50 kW	75 kW	—	—
ZH 829	6 kW	6 kW	3 kW	3 kW
ZH 500 ZH 800	16 kW	16 kW	16 kW	16 kW
ZH 500 ZH 800 ZH 801	50 kW	50 kW	50 kW	50 kW
S 195 BE	80 kW	80 kW	—	—

3.0. Device Data

3.1. Electronic Contactor ZH 767

The solid state contactors, type ZH 767, are designed for a nominal switching capacity of 50 kW AC (ZH 767E) and 75 kW AC (ZH 767F) respectively. Thyristors are employed for load switching. Therefore, resistive AC loads can be controlled without wear and maintenance at extremely high cycle rates.

No audible noise is generated by the switching operation. The usage of these devices on board of passenger railcars (coaches, dining and sleeping cars) therefore improves the passenger comfort level considerably.

The correct functioning of the device is monitored by a short circuit proof output (Max. short circuit current = 100 mA).

In the off position, the load is galvanically not completely disconnected. The reverse current in this state amounts to < 5 mA at a supply frequency of 16 Hz. The reference potential for the load (for passenger cars normally „ground“) must be connected.



Type ZH 767E

Technical Data		
Service Category	AC 1	
Continuous Thermal Current	50 A	
Number of Main Contacts	One solid state output	
Rated Switching Capacity	ZH 767E: $U_N = 1000V 16^{2/3} - 50 Hz$	50 kW
	ZH 767F: $U_N = 1500V 16^{2/3} - 50 Hz$	75 kW
Max. Switching Capacity at 1000V, pf 1	100 kW	
Switching Cycles per Hour	no restrictions	
Mechanical Life / Cycles	>> 10×10^6	
Insulation	VDE 0115 Group D, tested at 4,5 kW at $U_N = 1000 V$	
Control Power	< 2 W	
Nominal DC Control Voltage	10 V to 150 V	
Voltage Range	0,7 to 1,25 U_{Nenn}	
Operating Temperature Range	-25°C to +70°C	
Standards	IEC 77; VDE 0115; VDE 0660	
Shock resistance	5 g	
Weight	approx. 3,4 kg	
Mounting Orientation	upright (s. fig. on left)	
Auxiliary Contacts	Monitoring output (50 mA)	
Termination	Main Contacts	M6
	Control & Monitor Terminals	Spring loaded box terminal 0,14 - 2,5 mm ²
Part Number	ZH 767E	1751. 0254 616
	ZH 767F	1751. 0254 627

Circuit:

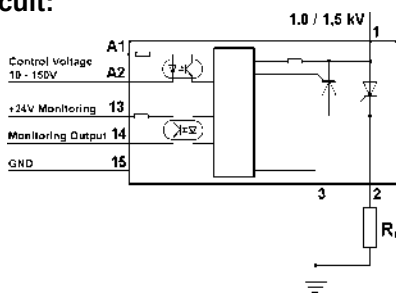

Mounting Template:

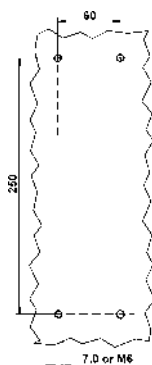

Device Dimensions:

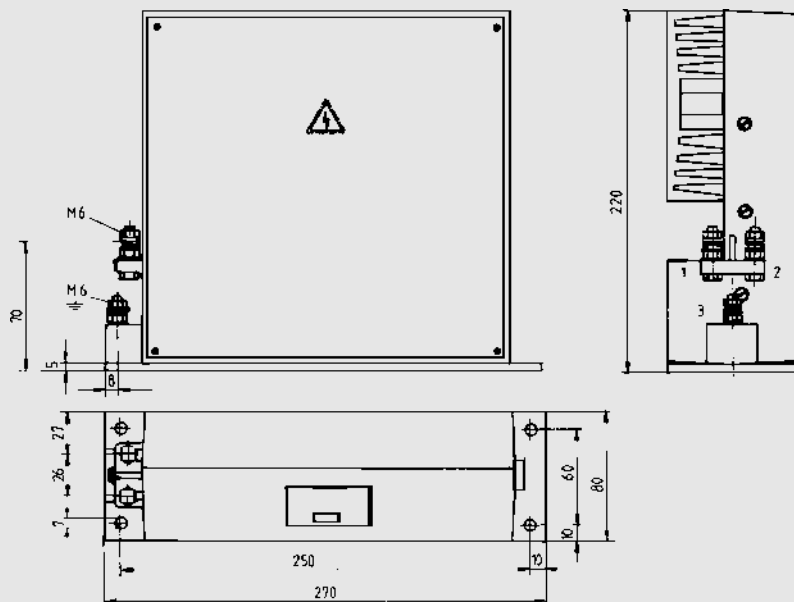

3.2. Contactor Type ZH 829

Type ZH 829 Contactors are designed for nominal loads of 6 kW AC and 3 kW DC respectively. They are suitable for switching of smaller variable voltage loads. Double-break contacts ensure safe turn-off. Guide horns direct the arc into the attached arc chamber.



Type ZH 829

Technical Data		
Application Category		AC 1 DC 1
Continuous Thermal Current		6 A
Number of Main Contacts		1 NO
Rated Switching Capacity	$U_N = 1500V 16^{2/3}$ to 50 Hz	6 kW
	$U_N = 3000V$ DC	3 kW
Max. Switching Capacity	$U = 2700V$ DC	30 kW
	$U = 4000V$ DC	18 kW
Switching Cycles per Hour (under load)		120
Mechanical Life		1×10^6
Insulation VDE 0115 Group D, tested at 20 kV at $U_N = 3000 V$ DC		
Coil Wattage (warm)		7 W
Nominal DC Control Voltage		10 V ... 120 V
Voltage Range		0,7 to 1,25 U_{Nem}
Operating Temperature Range (100% ON)		-25°C to +70°C
Storage Temperature Range		-40°C to +80°C
Standards		IEC 77; VDE 0115; VDE 0660
Arc Suppression		Arc Chute / Suppression
Transient Suppression		Suppression Module (not ZH 829b)
Shock resistance		5 g
Weight		approx. 2,3 kg
Mounting Orientation		no restrictions
Auxiliary Contacts		optional S 840 (see list D 19)
Termination	Main Contact	M4
	Coil	Quick Connect A 6,3 x 0,8

For ordering information see page 10

Circuit:

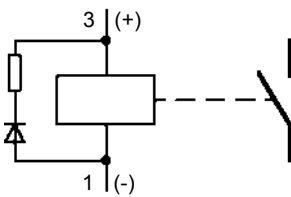

Mounting Template:

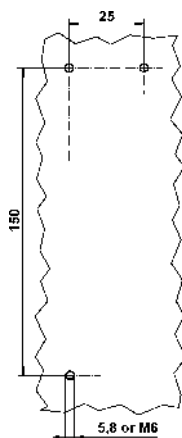

Device Dimensions:

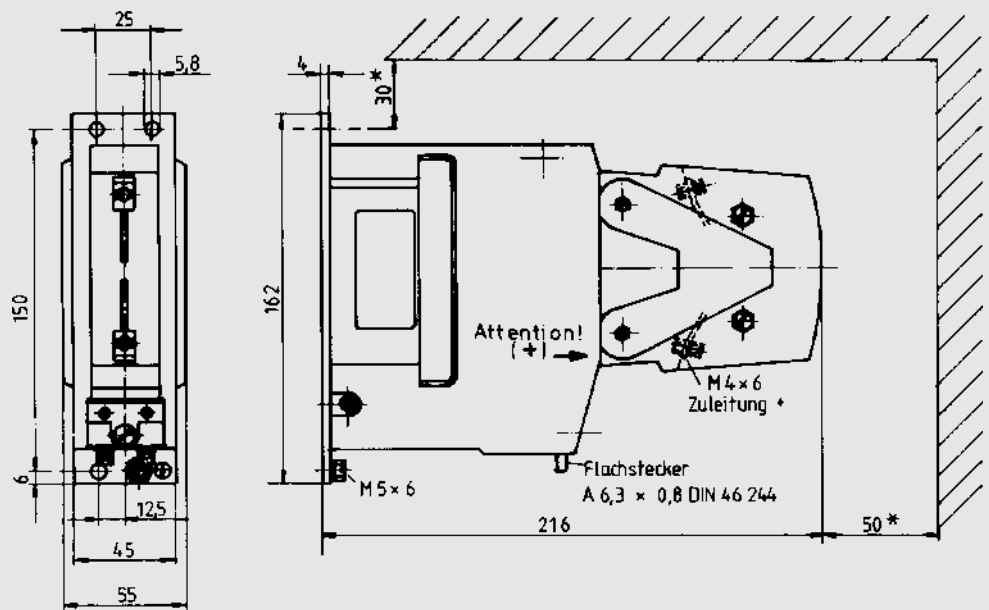

3.3. Contactor ZH 715 / 815

Type ZH 715 / ZH 815 Contactors are designed for a nominal load of 16 kW (AC or DC). They are suitable for application as main contactors in power supplies and as control contactors for resistor banks in heating and air conditioning equipment. Double-break contacts ensure safe turn-off. Arc suppression is accomplished in the attached arc chute. In DC applications permanent-magnet suppression is used.

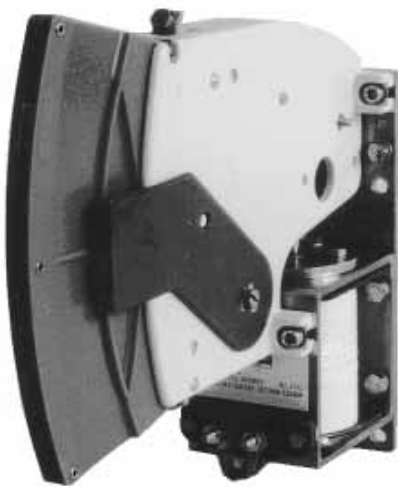

Type ZH 715

Technical Data		
Application Category		AC 1 DC 1
Continuous Thermal Current		50 A
Number of Main Contacts		1 (normally open)
Rated Switching Capacity	$U_N = 1500V$ AC	16 kW
	$U_N = 3000V$ DC	16 kW
Max. Switching Capacity		$U = 3000V$ DC 90 kW
Switching Cycles per Hour (under load)		120
Mechanical Life		1×10^6
Insulation		VDE 0115 Group D, tested at 10 kV at $U_N = 3000$ V DC
Coil Wattage (warm)		7 W
Nominal DC Control Voltage		24 V ... 120 V
Voltage Range		0,7 to 1,25 U_{Nenn}
Operating Temperature Range (100% ON)		-25°C to +70°C
Storage Temperature Range		-40°C to +80°C
Standards		IEC 77; VDE 0115; VDE 0660
Arc Suppression		Arc Chute / Permanent Magnet Suppression
Transient Suppression		Suppression Module
Shock resistance		5 g
Weight		approx. 3,3 kg
Mounting Orientation		no restrictions
Auxiliary Contacts		for ZH 815 only S 800 (see list D 20)
Termination	Main Contact	M5
	Coil	M3

For ordering information see page 10

Circuits:

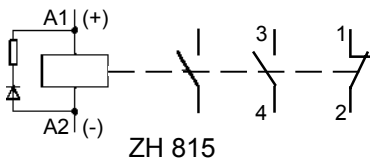
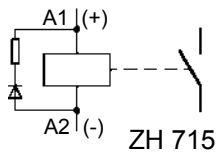

Mounting Template:

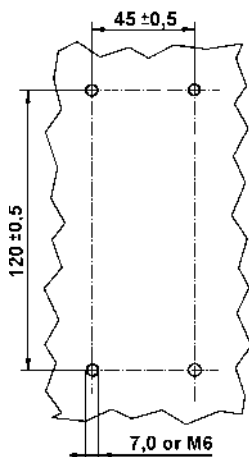

Device Dimensions:

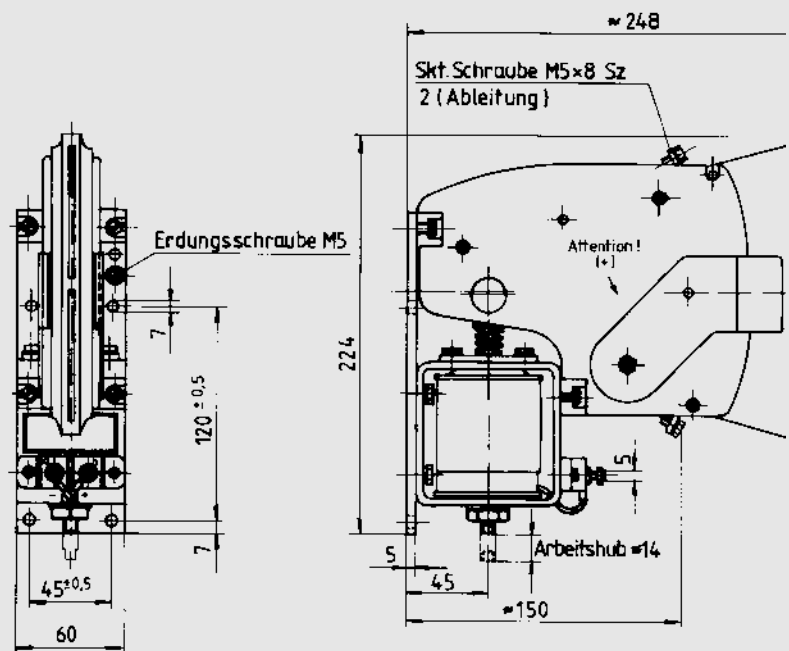

3.4. Contactor Type ZH 500 / 800 / 801

These contactors are designed for a nominal load of 50 kW (AC and DC). They are primarily used for load switching in power supply systems and as heater bank main and control contactors for air conditioning and heating systems. Arc horns on the fixed contacts guide the arc into the attached arc chute. Double-break contacts ensure safe turn-off. Double-break contacts ensure safe turn-off.



Type ZH 800

Technical Data		
Application Category	AC 1 DC 1	
Continuous Thermal Current	80 A	
Number of Main Contacts	1 (normally open)	
Rated Switching Capacity	$U_N = 1500V$ AC $U_N = 3000V$ DC	50 kW 50 kW
Max. Switching Capacity	$U = 3600V$ DC	150 kW
Switching Cycles per Hour (under rated load)		30
Mechanical Life		1×10^6
Insulation	VDE 0115 Group D, tested at 10 kV at $U_N = 3000 V$ DC	
Coil Wattage (warm)		15 W
Nominal DC Control Voltage		24 V ... 220 V
Voltage Range		0,7 to 1,25 U_{Nenn}
Operating Temperature Range (100% ON)		-25°C to +70°C
Storage Temperature Range		-40°C to +80°C
Standards	IEC 77; VDE 0115; VDE 0660	
Arc Suppression	Arc Chute / Permanent Magnet Suppression	
Transient Suppression	Suppression Module	
Shock resistance		5 g
Weight		approx. 4,2 kg
Mounting Orientation	hanging coil down	
Auxiliary Contacts	2 x S 800 (see list D 20)	
Termination	Main Contact	M6
	Coil	M3

For ordering information see page 10

Circuits:

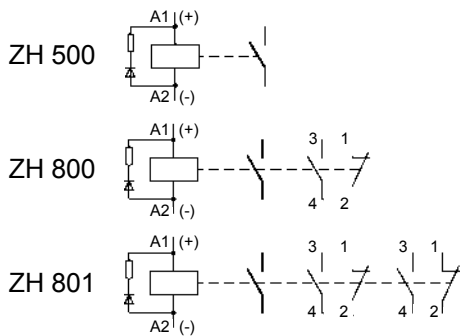

Device Dimensions:

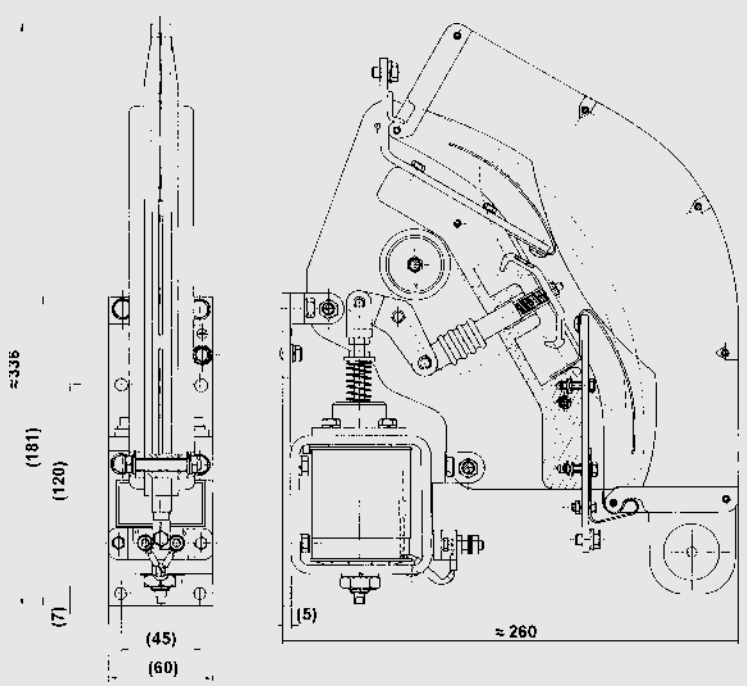
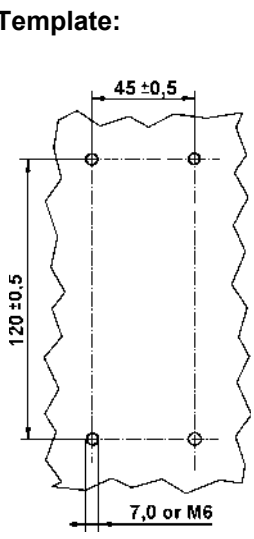

3.5. Contactor Type S 195 BE

The Type S 195 BE contactor is designed for 80 kW AC applications. Double-break contacts ensure safe turn-off. Contoured contacts direct the arc into the arc chute. Outstanding features of this device are its robust construction, minimal space requirements and a low price. It can also be equipped with an adapter plate to serve as a replacement for contactor types ZH 237, ZH 537 and ZH 637.



Type S 195 BE

Technical Data		
Application Category		AC 1
Continuous Thermal Current	Wire Size 50 mm ²	250 A
	Wire Size 70 mm ²	280 A
	Wire Size 95 mm ²	300 A
Number of Main Contacts		1 (normally open)
Rating Switch Capacity	U _N = 1500V AC	80 kW
Max. Switching Capacity	U _N = 1370V 50Hz pf = 0,80	315 kW
	U _N = 1800V 50Hz pf = 0,80	280 kW
Switching Cycles per Hour (no load)		3600
Mechanical Life		>3 x 10 ⁶
Insulation	Tested at 6 kV per IEC 77, Creep and arcing distance for pollution degree 2 for U _N = 1600 V and pollution degree 3 for U _N = 1000 V (VDE 0660, part 100)	
Coil Wattage (warm)		18 W
Nominal DC Control Voltage		24 V ... 110 V
Voltage Range		0,7 to 1,25 U _{Nem}
Operating Temperature Range (100% ON)		-25°C to +70°C
Storage Temperature Range		-40°C to +80°C
Standards	IEC 77; VDE 0115; VDE 0660	
Arc Suppression		Arc Chute
Transient Suppression		Varistor
Shock resistance		5 g
Weight		approx. 1,8 kg
Mounting Orientation	no restrictions except hanging (mounting plate on top)	
Auxiliary Contacts		S 870
Termination	Main Contact	M8
	Coil	Quick Connect A 6,3

For ordering information see page 10

Device Codes for Series S 195

S 1 9 5 - B E - 0 - 1 1 0

Series _____
 Nominal Voltage _____
 BE = 1500V AC, Railroad Service

Coil Voltage _____
 110V (24, 48V, 72V, special voltages)
 Auxiliary Contacts _____
 0 = None
 3 = 2 Aux. Contacts S870W1D1a012 with quick connect

Circuit:

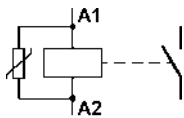

Mounting Template:

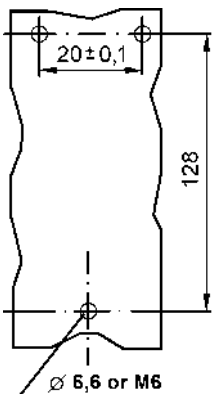

Device Dimensions:

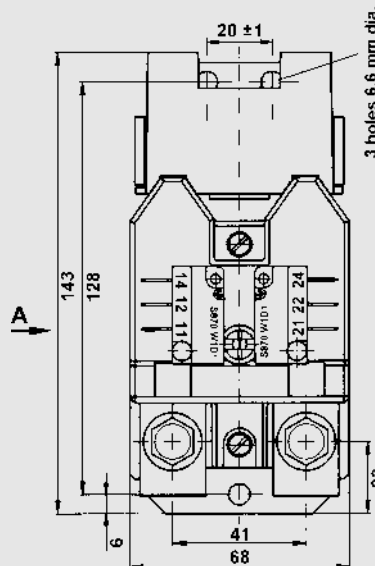

View A

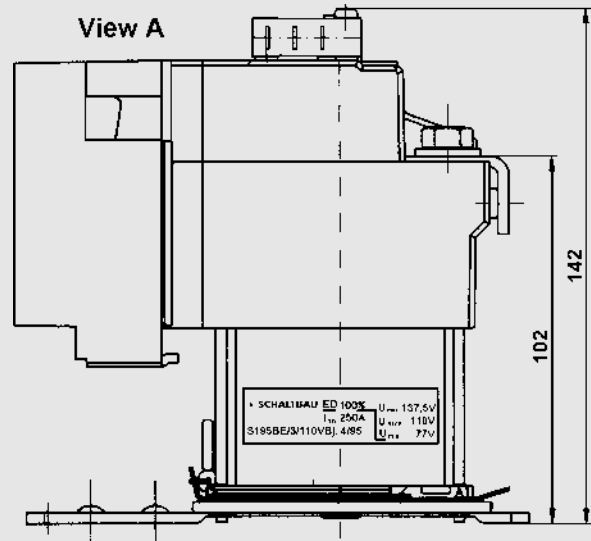

4.0. Ordering Information

4.1. Ordering Codes for Type ZH 829

<i>Type</i>	<i>Coil Voltage (DC)</i>	<i>Suppression</i>	<i>Part Number</i>
ZH 829	24 V	ja	1752. 0336 569
ZH 829	48 V	ja	1752. 0303 832
ZH 829	72 V	ja	1752. 0342 837
ZH 829b	24 V	nein	1752. 0744 073
ZH 829b	72 V	nein	1752. 0562 611
ZH 829b	120 V	nein	1752. 0562 655

4.2. Ordering Codes for Types ZH 715 / ZH 815

<i>Type</i>	<i>Coil Voltage (DC)</i>	<i>Aux. Contacts</i>	<i>Part Number</i>
ZH 715a	24 V	nein	1752. 0259 075
ZH 715b	54 V	nein	1752. 0259 086
ZH 715c	72 V	nein	1752. 0259 097
ZH 715d	120 V	nein	1752. 0259 100
ZH 715e	36 V	nein	1752. 0573 531
ZH 815e	24 V	1 x S 800a	1752. 0337 084
ZH 815f	54 V	1 x S 800a	1752. 0337 095
ZH 815g	72 V	1 x S 800a	1752. 0337 108
ZH 815h	120 V	1 x S 800a	1752. 0337 119

4.3. Ordering Codes for Types ZH 500 / ZH 800 / ZH 801

<i>Type</i>	<i>Coil Voltage (DC)</i>	<i>Aux. Contacts</i>	<i>Part Number</i>
ZH 500a	24 V	nein	1752. 0259 031
ZH 500f	54 V	nein	1752. 0259 053
ZH 500g	72 V	nein	1752. 0259 064
ZH 500h	120 V	nein	1752. 0259 042
ZH 500i	36 V	nein	1752. 0573 473
ZH 800a	24 V	1 x S 800a	1752. 0336 796
ZH 800b	54 V	1 x S 800a	1752. 0336 809
ZH 800c	72 V	1 x S 800a	1752. 0336 810
ZH 800d	120 V	1 x S 800a	1752. 0336 821
ZH 800e	220v	1 x S 800a	1752. 0438 063
ZH 801a	24 V	2 x S 800a	1752. 0344 582
ZH 801b	54 V	2 x S 800a	1752. 0344 593
ZH 801c	72 V	2 x S 800a	1752. 0344 606
ZH 801d	120 V	2 x S 800a	1752. 0344 617
ZH 801e	220 V	2 x S 800a	1752. 0334 201

Notes

Notes

Electrical Components and Systems for Transportation and Industrial Applications

Connectors	<ul style="list-style-type: none"> • Industry-standard connectors • Special connectors for communication technology (MIL-connectors) • Connectors for railway technology including UIC connectors • Special connectors according to customer requirements
Snap Action Switches	<ul style="list-style-type: none"> • Snap-action switches with direct opening action • Snap-action switches with self-cleaning contacts • Special switches according to customer requirements
Contactors	<ul style="list-style-type: none"> • Single and multipole DC contactors • High-voltage AC/DC contactors • Contactors for battery powered vehicles and power supplies • Contactors for railway applications • Single terminals and fuse holders • DC emergency break switches • Special contactors according to customer requirements
Control Devices	<ul style="list-style-type: none"> • Master controllers and reversers for railway applications • Toggle switches • Hand- and foot switches for railway applications (Dead Man's Devices) • Switching elements with high breaking capacity • Emergency brake handles • Signal devices
Transportation	<ul style="list-style-type: none"> • Power supply systems and equipment for passenger coaches • Battery chargers for locomotives and restaurant cars • High-voltage equipment for single and multi-voltage operation • Heaters • Design and engineering for passenger coaches • Design and engineering for DMUs and EMUs • Special devices and engineering according to customer requirements

Schaltbau GmbH

Klausenburger Strasse 6
81677 Munich
Germany

Phone +49 89 9 30 05-0
Telefax +49 89 9 30 05-350
e-Mail schaltbau@schaltbau.de
Internet <http://www.schaltbau.de>

with compliments: