

Datasheet

Features

- 10-bit Resolution
- 2 Gsps Sampling Rate
- Selectable 1:2 or 1:4 Demultiplexed Output
- 500 mVpp Differential 100Ω or Single-ended 50Ω Analog Input
- 100Ω Differential or Single-ended 50Ω Clock Input
- LVDS Output Compatibility
- Functions:
 - ADC Gain Adjust
 - Sampling Delay Adjust
 - 1:4 Demultiplexed Simultaneous or Staggered Digital Outputs
 - Data Ready Output with Asynchronous Reset
 - Out-of-range Output Bit (11th Bit)
- Power Consumption: 6.5W
- Power Supplies: -5V, -2.2V, 3.3V and V_{PLUSD} Output Power Supply
- Package
 - Cavity Down EBGA 317 (Enhanced Ball Grid Array)
 - 25 × 35 mm Dimensions



Performances

- 3 GHz Full Power Analog Input Bandwidth
- -0.5 dB Gain Flatness from DC up to 1.5 GHz
- Single-tone Performance at $F_s = 2$ Gsps, Full First and Second Nyquist (-1 dBFS)
 - ENOB = 7.8 Effective Bits, $F_{IN} = 1000$ MHz
 - SNR = 51 dBc, SFDR = -55 dBc, $F_{IN} = 1000$ MHz
 - ENOB = 7.5 Effective Bits, $F_{IN} = 2$ GHz
 - SNR = 50 dBc, SFDR = -54 dBc, $F_{IN} = 2$ GHz
- Dual-tone Performance (IMD3) at $F_s = 2$ Gsps (-7 dBFS Each Tone)
 - $F_{in1} = 945$ MHz, $F_{in2} = 955$ MHz: IMD3 = -60 dBFS
 - $F_{in1} = 1545$ MHz, $F_{in2} = 1555$ MHz: IMD3 = -60 dBFS

Screening

- Temperature Range:
 - $T_{amb} > 0^\circ\text{C}$; $T_J < 90^\circ\text{C}$ (Commercial C Grade)
 - $T_{amb} > -40^\circ\text{C}$; $T_J < 110^\circ\text{C}$ (Industrial V Grade)

Visit our website: www.e2v.com
for the latest version of the datasheet

Applications

- Direct RF Down Conversion
- Broadband Digital Receivers
- Test Instrumentation
- High Speed Data Acquisition
- High Energy Physics

1. Description

The AT84AS004 combines a 10-bit 2 Gsps analog-to-digital converter with a 1:4 DMUX, designed for accurate digitization of broadband signals in either first or second Nyquist zone. It features 7.8 Effective Number of Bits (ENOB) and -55 dBFS Spurious Free Dynamic Range (SFDR) at 2 Gsps over the full first Nyquist zone and 7.5-bit with 54 dB SFDR over full second Nyquist.

The 1:4 demultiplexed digital outputs are LVDS logic compatible, allowing easy interfacing with standard FPGAs or DSPs. The AT84AS004 operates at up to 2 Gsps.

The AT84AS004 comes in a 25 × 35 mm EBGA317 package. This package has the same TCE as FR4 boards, offering excellent reliability when subjected to large thermal shocks.

2. Block Diagram

Figure 2-1. Block Diagram

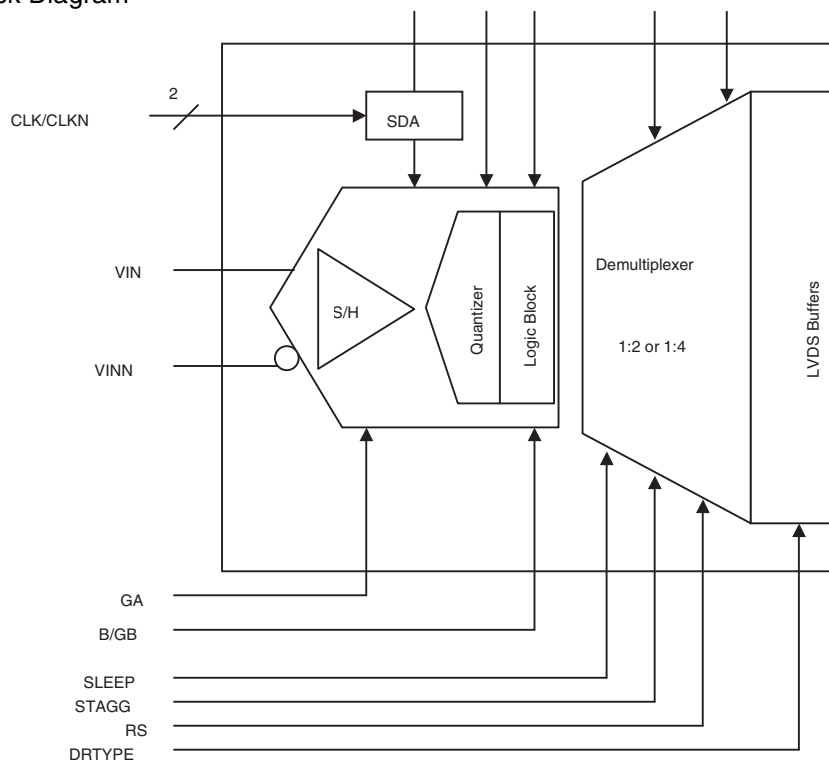

3. Functional Description

The AT84AS004 is a 10-bit 2 Gsps ADC combined with a 1:4 demultiplexer (DMUX) allowing to lower the 11 bit output data stream (10-bit data and one out-of-range bit) by a selectable factor of 4 or 2. The ADC works in fully differential mode from analog input through to digital outputs.

The ADC should be 50Ω reverse terminated, as close as possible to the EBGA Package input pin (1 mm maximum). The ADC Clock input is on-chip 100Ω differentially terminated. The output clock and the output data are LVDS logic compatible, and should be 100Ω differentially terminated.

The AT84AS004 ADC features two asynchronous resets:

- DRRB, which ensures that the first digitized data corresponds to the first acquisition.
- ASYNCRST, which ensures that the first digitized data will be output on port A of the DMUX.

The ADC gain can be tuned-in to unity gain by the means of the GA analog control input A Sampling Delay Adjust function (SDA analog control input, activated via the SDAEN signal) may be used to fine-tune the ADC aperture delay by ± 120 ps around its center value. The SDA function may be of interest for interleaving multiple ADCs. The control pin B/GB is provided to select either a binary or gray data output format.

A tunable delay cell (controlled via CLKDACTRL) is integrated between the ADC and the DMUX on the clock path to fine tune the data vs. clock alignment at the interface between the ADC and the DMUX. This delay can be tuned from -275 to 275 ps around default center value, featuring a 550 ps typical delay tuning range. An extra standalone delay cell is also provided, (controlled via DACTRL analog control input and activated via DAEN). The tuning range is typically 550 ps.

A pattern generator (PGEB) is integrated in the ADC part for debug or acquisition setup. Similarly, a Built-in Self Test (BIST) is provided for quick debug of the DMUX part. The output demultiplexing 1:4 or 1:2 ratio can be selected by the means of RS digital control input.

Two modes for the output clock (via DRTYPE) can be selected:

- DR mode: only the output clock rising edge is active, the output clock rate is the same as the output data rate
- DR/2 mode: both the output clock rising and falling edges are active, the output clock rate is half the output data rate

The data outputs are available at the output of the AT84AS004 in two different modes:

- Staggered: even and odd bits come out with half a data period delay
- Simultaneous: even and odd bits come out at the same time

A Power reduction mode (SLEEP control input) is provided to reduce the DMUX power consumption.

The ADC junction temperature monitoring is made possible through the DIODE input by sensing the voltage drop across 1 diode implemented on the ADC close to chip hot point.

The AT84AS004 is delivered in an Enhanced Ball Grid Array (EBGA), very suitable for applications subjected to large thermal variations (thanks to its TCE which is similar to FR4 material TCE).

Table 3-1. Functions Description

Name	Function				
V _{CCA}	Analog 3.3V power supply	<p>The diagram shows the AT84AS004 chip with the following pins: V_{CCA} (3.3V), V_{EE} (-5V), V_{MINUSD} (-2.2V), V_{CCDVPLUSD} (3.3V), V_{PLUSD} (2.5V), AGND, DGND, VIN, VINN (2 pins), CLK, CLKN (2 pins), DRRB, ASYNCRST, SDAEN, SDA, GA, PGEB, B/GB, DACTRL, CLKDACTRL (2 pins), DAI, DAIN (2 pins), SLEEP, STAGG, CLKTYPE, RS, DAEN, BIST, DRTYPE, [A0...A9], [A0N...A9N], AOR/DRAN, AORN/DRA (2 pins), [B0...B9], [B0N...B9N], BOR/DRBN, BORN/DRB (2 pins), [C0...C9], [C0N...C9N], COR/DRCN, CORN/DRC (2 pins), [D0...D9], [D0N...D9N], DOR/DRDN, DORN/DRD (2 pins), DR, DRN (2 pins), DAO, DAON (2 pins), and DIODE ADC.</p>			
V _{CCD}	Digital 3.3 V power supply				
V _{EE}	Analog -5V power supply				
V _{PLUSD}	Output 2.5 V power supply				
V _{MINUSD}	Output -2.2V power supply				
AGND	Analog ground				
DGND	Digital ground				
CLK, CLKN	Input clock signals				
VIN, VINN	Analog input data				
DRRB	ADC reset				
ASYNCRST	DMUX asynchronous reset				
DR/DRN	Output clock signals				
A0...A9 A0N...A9N	Output data port A				
AOR/DRAN, AORN/DRA	Additional output bit port A or output clock in staggered mode for port A			Name	Function
B0...B9 B0N...B9N	Output data port B			DAI, DAIN	Input signals for standalone delay cell
BOR/DRBN, BORN/DRB	Additional output bit port B or output clock in staggered mode for Port B			DAO, DAON	Output signals for standalone delay cell
C0...C9 C0N...C9N	Output data Port C	GA	ADC gain adjust		
		SDAEN	ADC SDA enable		
COR/DRCN, CORN/DRC	Additional output bit port C or Output clock in staggered mode for Port C	SDA	ADC sampling delay adjust		
		PGEB	ADC pattern generator		
D0...D9 D0N...D9N	Output data Port D	B/GB	Binary or gray output code selection		
		SLEEP	Sleep mode selection signal		
DOR/DRDN, DORN/DRD	Additional output bit Port D or output clock in staggered mode for Port D	STAGG	Staggered mode selection for data outputs		
RS	DMUX ratio selection signal	CLKTYPE	Input clock type selection signal (to be connected to V _{CCD} or left floating)		
CLKDACTRL	Control signal for clock delay cell	DRTYPE	Output clock type selection signal		
DACTRL	Control signal for standalone delay cell	BIST	Built-in Self Test		
DAEN	Enable signal for standalone delay cell	DIODE ADC	Diode for die junction temperature monitoring (ADC)		

4. Specifications

4.1 Absolute Maximum Ratings

Table 4-1. Absolute Maximum Ratings

Parameter	Symbol	Value	Unit
Analog positive supply voltage	V_{CCA}	GND to 6	V
Digital positive supply voltage	V_{CCD}	GND to 3.6	V
Analog negative supply voltage	V_{EE}	GND to -5.5	V
Digital positive supply voltage	V_{PLUSD}	GND to 3	V
Digital negative supply voltage	V_{MINUSD}	GND to -3	V
Maximum difference between V_{PLUSD} and V_{MINUSD}	$V_{PLUSD} - V_{MINUSD}$	5	V
Analog input voltages	V_{IN} or V_{INN}	-1.5 to 1.5	V
Maximum difference between V_{IN} and V_{INN}	V_{IN} or V_{INN}	-1.5 to 1.5	
Clock input voltage	V_{CLK} or V_{CLKN}	-1 to 1	V
Maximum difference between V_{CLK} and V_{CLKN}	$V_{CLK} - V_{CLKN}$	-1 to 1	V _{pp}
Control input voltage	GA, SDA	-1 to 0.8	V
Digital input voltage	SDAEN, B/GB, PGEB, DECB	-5 to 0.8	V
ADC reset voltage	DRRB	-0.3 to $V_{CCA} + 0.3$	V
DMUX function input voltage	RS, CLKTYPE, DRTYPE, SLEEP, STAGG, BIST, DAEN	-0.3 to $V_{CCD} + 0.3$	V
DMUX asynchronous reset	ASYNCRST	-0.3 to $V_{CCD} + 0.3$	
DMUX input voltage	DAI, DAIN	-0.3 to $V_{CCD} + 0.3$	V
DMUX control voltage	CLKDACTRL, DACTRL	-0.3 to $V_{CCD} + 0.3$	V
Maximum input voltage on DIODE	DIODE ADC	700	mV
Maximum input current on DIODE	DIODE ADC	1	mA
Junction temperature	T_J	135	°C

- Note:
1. Absolute maximum ratings are short term limiting values (referenced to GND = 0 V), to be applied individually, while other parameters are within specified operating conditions. Long exposure to maximum ratings may affect device reliability.
 2. All integrated circuits have to be handled with appropriate care to avoid damage due to ESD. Damage caused by inappropriate handling or storage could range from performance degradation to complete failure.

Table 4-2. Recommended Condition of Use

Parameter	Symbol	Comments	Recommended Value	Unit
Positive supply voltage	V_{CCA}		3.3	V
Positive supply voltage	V_{CCD}		3.3	V
Negative supply voltage	V_{EE}		-5.0	V
Positive negative supply voltage	V_{MINUSD}		-2.2	V
Differential analog input voltage	$V_{IN} - V_{INN}$		500	mVpp
Differential clock input level	V_{inclk}	50 Ω single-ended (V_{INN} grounded through 50 Ω)	± 125 500	mV mVpp
Clock input power level (ground common mode)	P_{CLK} P_{CLKN}	50 Ω single-ended clock input or 100 Ω differential clock (recommended)	0	dBm
ADC control input voltage	GA, SDA		-0.5 to 0.5	V
ADC functions	SDAEN, B/GB, PGEB, DECB		GND or VEE	V
ADC reset	DRRB		GND to 3.3V	V
DMUX standalone delay cell inputs	DAI, DAIN		GND to 3.3V	V
DMUX control inputs	SLEEP, STAGG, ASYNCRST, BIST, RS, DAEN, DRTYPE, CLKDACTRL, DACTRL		GND to 3.3V	V
Operating temperature range	T_C ; T_J	Commercial C grade industrial V grade	0 $^{\circ}$ C < T_C ; T_J < 90 $^{\circ}$ C -20 $^{\circ}$ C < T_C ; T_J < 110 $^{\circ}$ C	$^{\circ}$ C
Storage temperature	T_{stg}		-65 to 150	$^{\circ}$ C
Maximum junction temperature	T_J		125	$^{\circ}$ C

4.2 Electrical Operating Characteristics

- $V_{CCA} = V_{CCD} = 3.3V$, $V_{EE} = -5V$, $V_{MINUSD} = -2.2V$
- $V_{INN} - V_{INN} = 1$ dBFS (single-ended driven with VINN connected to ground via 50Ω)
- PCLK = 0 dBm (differential driven)

Table 4-3. DC Electrical Characteristics at Ambient Temperature and Hot Temperature (TJ Max)

Parameter	Test Level	Symbol	Min	Typ	Max	Unit
Resolution				10		Bit
Power Requirements						
Positive Supply Voltages	-analog -digital -digital outputs	V_{CCA} V_{CCD} V_{PLUSD}	3.15 3.15 2.4	3.3 3.3 2.5	3.45 3.45 2.6	V V V
Positive Supply Current	-analog $V_{CCA} = 3.3V$ -digital $V_{CCD} = 3.3V$ (1:2 DMUX) -digital $V_{CCD} = 3.3V$ (1:4 DMUX) -output $V_{PLUSD} = 2.5V$	I_{VCCA} I_{VCCD} I_{VCCD} I_{VPLUSD}		80 535 565 450	100 590 620 470	mA mA mA mA
Negative supply voltage	V_{EE}	V_{EE}	-5.25	-5	-4.75	V
Negative supply current		I_{VEE}		620	660	mA
Negative supply voltage		V_{MINUSD}	-2.3	-2.2	-2.1	V
Negative supply current		$I_{V_{MINUSD}}$		190	200	mA
Power Dissipation (1:2 DMUX)		P_D		6.5	7.1	W
Analog Inputs						
Full-scale input voltage range		V_{IN}	-125		125	mV
Differential mode 0V common mode voltage		V_{INN}	-125		125	mV
Full-scale input voltage range	Single-ended input option 0V common mode voltage	V_{IN}, V_{INN}	-250	0	250	mV
Analog input power level (50Ω single-ended)		P_{IN}		-2		dBm
Analog input capacitance (die)		C_{IN}		0.3		pF
Input leakage current		I_{IN}		10		μA
Input resistance	-single-ended	R_{IN}	49	50	51	Ω
	-differential	R_{IN}	98	100	102	Ω

Table 4-3. DC Electrical Characteristics at Ambient Temperature and Hot Temperature (TJ Max) (Continued)

Parameter	Test Level	Symbol	Min	Typ	Max	Unit
Clock Inputs						
Logic common mode compatibility for clock inputs	4		Differential ECL to LVDS (AC coupling)			
Clock input common voltage range (V _{CLK} or V _{CLKN}) (0V common mode)		V _{CM}	-1.2	0	0.3	V
Clock input power level (low-phase noise sinewave input) 50Ω single-ended or 100Ω differential		P _{CLK}	-4	0	4	dBm
Clock input swing (single ended with CLKN = 50Ω to GND)		V _{CLK}	±200	±320	±500	mV
Clock input swing (differential voltage) on each clock input		V _{CLK} , V _{CLKN}	±141	±226	±354	mV
Clock input capacitance (die)		C _{LK}		0.3		pF
Clock input resistance - Single-ended - Differential ended		R _{CLK} R _{CLK}	45 90	50 100	55 110	Ω Ω
Digital Data Outputs						
Logic compatibility			LVDS			
50Ω transmission lines, 100Ω (2 × 50Ω) differential termination) - Logic low - Logic high - Differential output - Common mode	1	V _{OL} V _{OH} V _{ODIFF} V _{OCM}	- 1.25 250 1.125	1.075 1.425 350 1.25	1.25 - 500 1.375	V V mV V
Control Function Inputs						
DRRB and ASYNCRST - Logic low - Logic high	1	V _{IL} V _{IH}	0 1.6		1.0 3.3	V V V
RS, DRTYPE, SLEEP, STAGG, BIST, DAEN - Logic low - Logic high	4	V _{IL} R _{IL} V _{IH} R _{IH}	0 2 10 K		0.5 10 Infinite	V Ω V Ω
SDAEN, PGEB, B/GB - Logic low - Logic high	1	V _{IL} V _{IH}	-2	V _{EE} 0	-3 0	V V
DAI, DAIN - Differential input - Common mode	1	V _{IDIFF} V _{ICM}	1 100	1.25 350	1.6 -	V mV

Table 4-3. DC Electrical Characteristics at Ambient Temperature and Hot Temperature (TJ Max) (Continued)

Parameter	Test Level	Symbol	Min	Typ	Max	Unit
GA, SDA	1		-0.5		0.5	V
CLKDACTRL, DACTRL	1		$1/3 \times V_{CCD}$		$2/3 \times V_{CCD}$	V
DC accuracy						
DNLrms	1	DNLrms		0.2	0.3	LSB
Differential non-linearity ⁽¹⁾	1	DNL ⁺		0.8	1.5	LSB
Integral non-linearity ⁽¹⁾	1	INL ⁻	-4	-2		LSB
Integral non-linearity ⁽¹⁾	1	INL ⁺		2	4	LSB
Gain central value ⁽²⁾	1		0.95	1	1.05	
Gain error drift	4			23	35	ppm/°C
Input offset voltage	1		-10		10	mV

- Note:
1. Histogram testing at $F_s = 390$ Msps $F_{in} = 100$ MHz.
 2. This range of gain can be set to 1 thanks to the gain adjust function.

Table 4-4. AC Electrical Characteristics at Ambient Temperature and Hot Temperature (T_J Max)

Parameter	Test Level	Symbol	Min	Typ	Max	Unit
AC Analog Inputs						
Full power input bandwidth ⁽¹⁾	4	FPBW		3		GHz
Small signal input bandwidth (10% full-scale) ⁽¹⁾		SSBW		3.3		GHz
Gain flatness ⁽²⁾		BF		-0.5		dB
Input voltage standing wave ration ⁽³⁾		VSWR		1.1: 1	1.2: 2	
AC Performance: Nominal Condition						
-1 dBFS single-ended input mode (unless otherwise specified); 50% clock duty cycle; 0 dBm differential clock (CLK,CLKN) binary output data format.						
Effective Number of Bits						
Fs = 1 Gsps Fin = 100 MHz	1	ENOB	7.4	8		Bit
Fs = 1.5 Gsps Fin = 750MHz	1		7.4	8		
Fs = 2 Gsps Fin = 1000 MHz	4		7.3	7.8		
Fs = 2 Gsps Fin = 2 GHz	4		7.1	7.5		
Signal to Noise Ratio						
Fs = 1 Gsps Fin = 100 MHz	1	SNR	50	52		dBc
Fs = 1.5 Gsps Fin = 750MHz	1		49	52		
Fs = 2 Gsps Fin = 1000 MHz	4		48	51		
Fs = 2 Gsps Fin = 2 GHz	4		48	50		
Total Harmonic Distortion						
Fs = 1 Gsps Fin = 100 MHz	1	ITHDI	46	52		dBc
Fs = 1.5 Gsps Fin = 750MHz	1		46	52		
Fs = 2 Gsps Fin = 1000 MHz	4		45	49		
Fs = 2 Gsps Fin = 2 GHz	4		45	49		
Spurious Free Dynamic Range						
Fs = 1 Gsps Fin = 100 MHz	1	ISFDRI	50	58		dBc
Fs = 1.5 Gsps Fin = 750MHz	1		50	58		
Fs = 2 Gsps Fin = 1000 MHz	4		48	55		
Fs = 2 Gsps Fin = 2 GHz	4		48	54		
Two-tone Third-order Inter-modulation Distortion						
Fs = 2 Gsps		IIMD3I				dBFS
Fin1 = 945 MHz, Fin2 = 955 MHz [-7 dBFS]	4			60		
Fin1 = 1545 MHz, Fin2 = 1555 MHz [-7 dBFS]	4			60		

- Note:
1. See "Definitions of Terms" on page 41.
 2. From DC to 1.5 GHz.
 3. Specified from DC up to 2.5 GHz input signal. Input VSWR is measured on a soldered device. It assumes an external $50\Omega \pm 2\Omega$ controlled impedance line, and a 50Ω driving source impedance ($S_{11} \leq 30$ dB).

Table 4-5. Transient and Switching Performances

Parameter	Test Level	Symbol	Min	Typ	Max	Unit
Transient Performance						
Bit error rate ⁽¹⁾	4	BER	10 ⁻¹¹			Error/sample
ADC setting time (V _{IN} -V _{INN} = 400 mVpp)	4	TS		400		ps
Overshoot recovery time	4	ORT			500	ps
ADC step response rise/fall time (10 –90%)	4			80	100	ps
Overshoot	5			4		%
Ringback	5			2		%
Switching Performance and Characteristics						
Maximum clock frequency ⁽²⁾	4	F _S Max	2			Gsps
Minimum clock frequency ⁽²⁾		F _S Min		150	200	Msps
Maximum clock pulse width (high)		TC1	0.22		2.5	ns
Minimum clock pulse width (low)		TC2	0.22		2.5	ns
Aperture delay ⁽²⁾		TA		160		ps
Aperture uncertainty		Jitter		150		fs rms
DRRB pulse width			1			ns
ASYNCRST pulse width			1			ns
Output Data						
Data Output Delay ⁽³⁾	4	TOD		7.1		ns
Data output delay Skew		T _{skew}			400	ps
Data pipeline delay - Synchronized 1:2 ratio - Synchronized 1:4 ratio - Staggered 1:2 ratio - Staggered 1:4 ratio		TPD		5.5 7.5 4.5/5.5 4.5/5.5/6.5/7.5		Clock cycles
Data output rise/fall time (20% to 80%)		TR/TF			650	ps
Output Clock						
Output clock delay ⁽³⁾	4	TDR		6.6		ns
Output clock rise/fall time (20% –80%)		TR/TF			650	ps
Output data to output clock propagation delay		TD2-TD1 TOD-TDR	200	500	600	ps

Table 4-5. Transient and Switching Performances (Continued)

Parameter	Test Level	Symbol	Min	Typ	Max	Unit
Standalone Delay Cell (DACTRL) and Tunable Delay cell (CLKDACTRL) ⁽⁴⁾						
Input frequency	4	FMSDA	600			MHz
Input duty cycle		DCYCSDA	40	50	60	%
Propagation delay with CLKDACTRL or DACTRL = $V_{CCD}/3$	4	TSDAMIN	1.70	2.00	2.30	ns
Propagation delay with CLKDACTRL or DACTRL = $2 \times V_{CCD}/3$	4	TSDAMAX	2.1	2.50	2.90	ns
Tuning range ⁽⁴⁾	4	SDARANGE	400	550	600	ps

- Note:
1. Output error amplitude < ± 6 LSB. $F_s = 2$ Gsps $T_J = 110^\circ\text{C}$.
 2. See “Definitions of Terms” on page 41.
 3. TOD and TDR propagation times are defined at package input/outputs. They are given for reference only. See “Definitions of Terms” on page 41.
 4. The delay cell used in both standalone delay cell and input clock path (DR) has a characteristic that is not linear with junction temperature. The largest tuning range is obtained near ambient temperature.

4.3 Explanation of Test Levels

Level	Comments
1	100% production tested at 25°C (for <i>C</i> Temperature range).
2	100% production tested at 25°C, and sample tested at specified temperatures (for <i>V</i> and <i>M</i> temperature ranges).
3	Sample tested only at specified temperatures
4	Parameter is guaranteed by design and characterization testing (thermal steady-state conditions at specified temperature).
5	Parameter is a typical value only guaranteed by design only

- Note: Unless otherwise specified:
Only minimum and maximum values are guaranteed (typical values are issued from characterization results).

4.4 Digital Coding

Differential Analog Input	Voltage Level	Digital Output			
		Binary (B/GB = GND or floating) MSB...LSB out-of-range		GRAY (B/GB = V _{EE}) MSB.....LSB out-of-range	
> 250.25 mV	>Top end of full-scale + ½ LSB	1 1 1 1 1 1 1 1 1 1	1	1 0 0 0 0 0 0 0 0 0	1
250.25 mV	Top end of full-scale + ½ LSB	1 1 1 1 1 1 1 1 1 1	0	1 0 0 0 0 0 0 0 0 0	0
249.75 mV	Top end of full-scale - ½ LSB	1 1 1 1 1 1 1 1 1 0	0	1 0 0 0 0 0 0 0 0 1	0
125.25 mV	3/4 full-scale + ½ LSB	1 1 0 0 0 0 0 0 0 0	0	1 0 1 0 0 0 0 0 0 0	0
124.75 mV	full-scale - ½ LSB	1 0 1 1 1 1 1 1 1 1	0	1 1 1 0 0 0 0 0 0 0	0
0.25 mV	Mid scale + ½ LSB	1 0 0 0 0 0 0 0 0 0	0	1 1 0 0 0 0 0 0 0 0	0
-0.25 mV	Mid scale - ½ LSB	0 1 1 1 1 1 1 1 1 1	0	0 1 0 0 0 0 0 0 0 0	0
- 124.75 mV	1/4 full-scale + ½ LSB	0 1 0 0 0 0 0 0 0 0	0	0 1 1 0 0 0 0 0 0 0	0
- 124.25 mV	1/4 full-scale - ½ LSB	0 0 1 1 1 1 1 1 1 1	0	0 0 1 0 0 0 0 0 0 0	0
- 249.75 mV	Bottom end of full-scale + ½ LSB	0 0 0 0 0 0 0 0 0 1	0	0 0 0 0 0 0 0 0 0 1	0
- 250.25 mV	Bottom end of full-scale - ½ LSB	0 0 0 0 0 0 0 0 0 0	0	0 0 0 0 0 0 0 0 0 0	0
≤ 250.25 mV	< Bottom end of full-scale - ½ LSB	0 0 0 0 0 0 0 0 0 0	1	0 0 0 0 0 0 0 0 0 0	1

5. Characterization Results

5.1 Nominal Conditions

Unless otherwise specified:

- $V_{CCA} = 3.3V$, $V_{CCD} = 3.3V$, $V_{EE} = -5V$, $V_{PLUSD} = 2.5V$, $V_{MINUSD} = -2.2V$
- $T_J = 80^\circ C$
- 50% clock duty cycle, binary output data format
- -1 dBFS analog input

5.2 Full Power Input Bandwidth

- Analog input level = -1 dBFS
- Gain flatness at -0.5 dB from DC to 1.5 GHz

Figure 5-1. Full Power Input Bandwidth at -3 dB

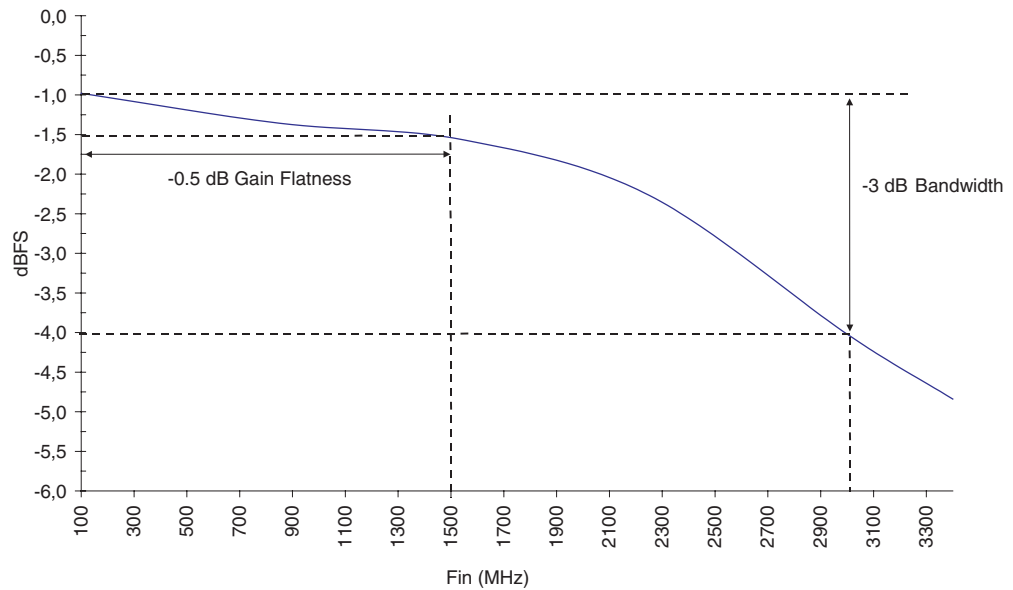

5.3 VSWR Versus Input Frequency

Figure 5-2. VSWR Curve for the Analog Input (VIN) and Clock (CLK)

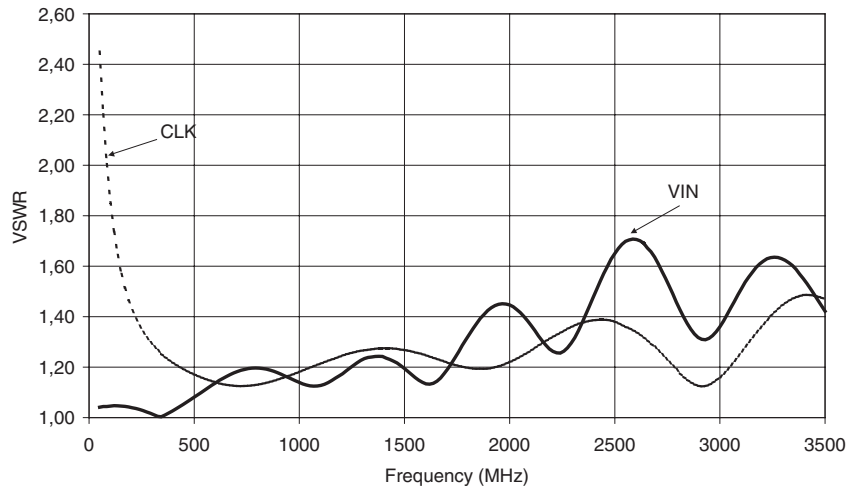

5.4 Step Response

- T_r measured = 114.8 ps = $\sqrt{T_{r_{PulseGenerator}}^2 + T_{r_{ADC}}^2}$
- $T_{r_{PulseGenerator}}$ (estimated) = 41 ps
- Actual $T_{r_{ADC}}$ = 107 ps

Figure 5-3. Step Response Rise Time ($F_s = 2$ Gsps, $F_{in} = 1$ GHz)

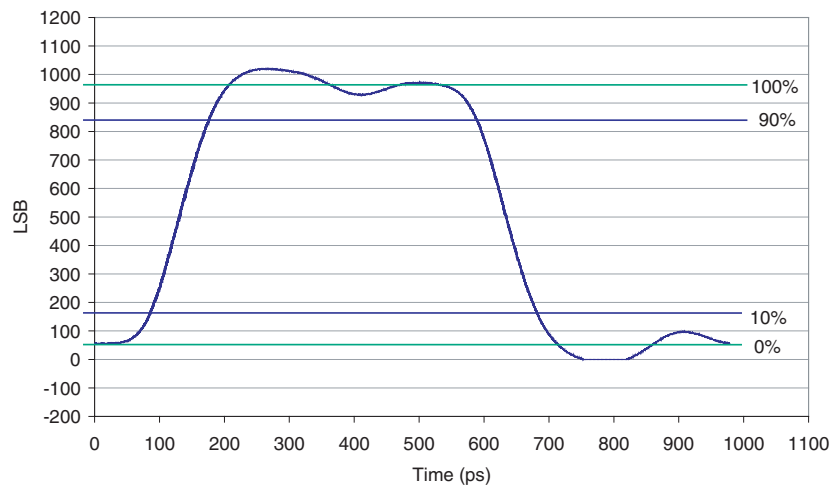

5.5 Dynamic Performance Versus Sampling Frequency

Figure 5-4. Dynamic Parameters Versus Sampling Frequency in Nyquist Conditions ($F_{in} = F_s/2$)

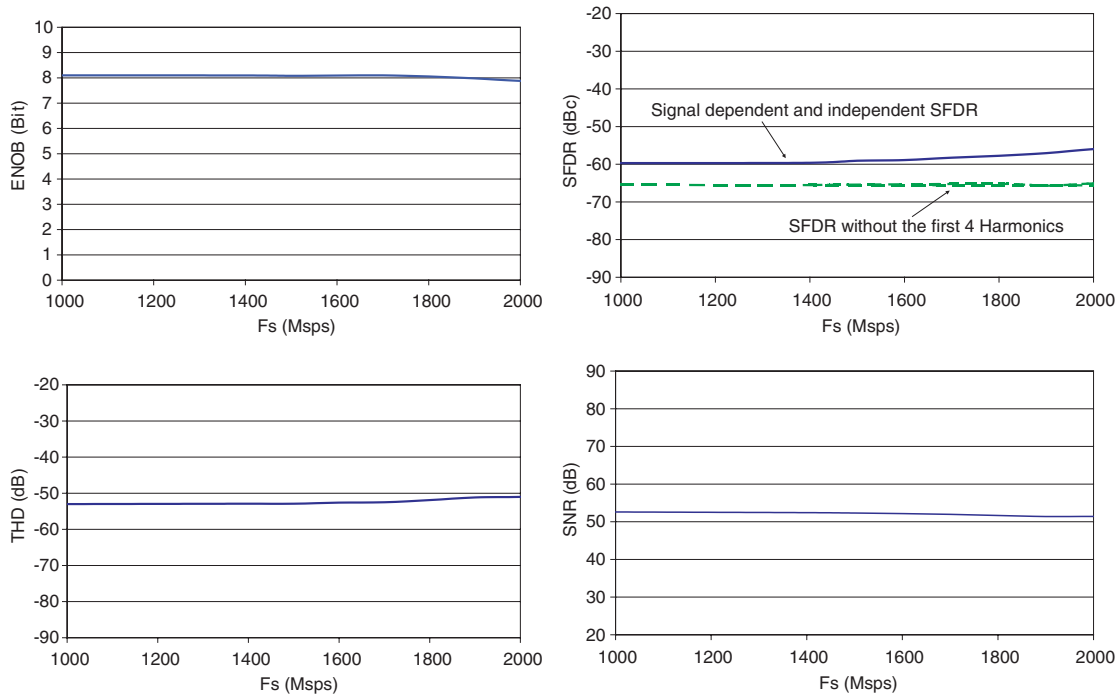

5.6 Dynamic Performance Versus Input Frequency

Figure 5-5. Dynamic Parameters Versus Input Frequency at $F_s = 2$ Gbps

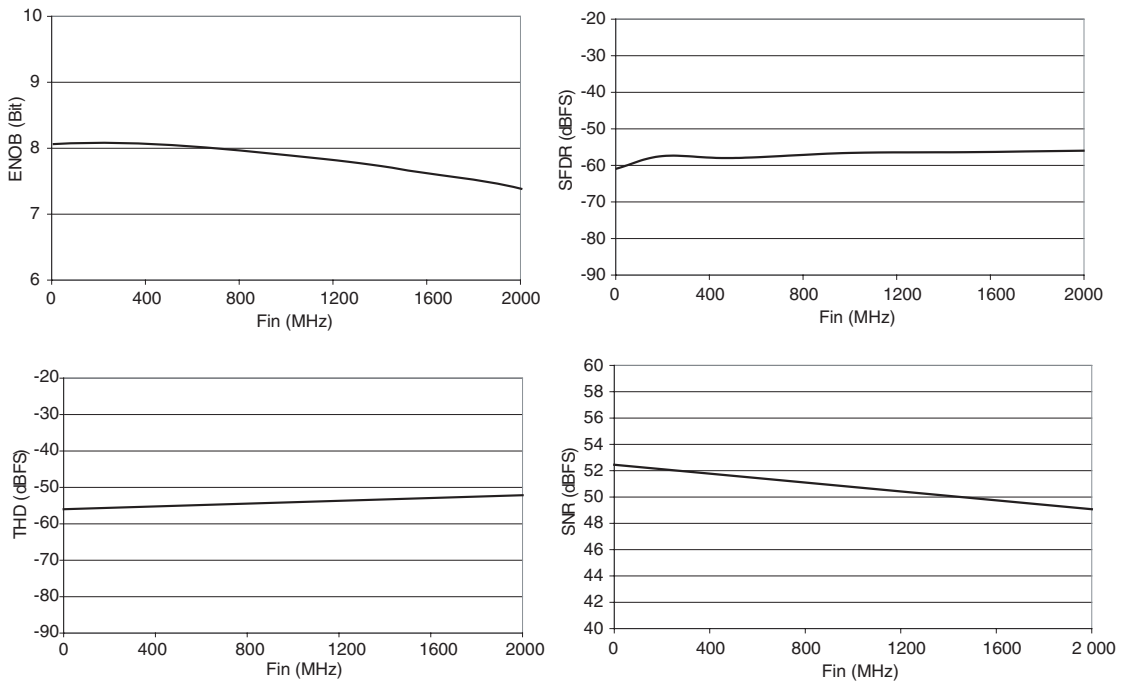

5.7 Signal Spectrum

Figure 5-6. $F_s = 2$ Gsps, $F_{in} = 998$ MHz -1 dBFS Analog Input, 1:4 Demultiplexing Factor, 32 kpoint FFT

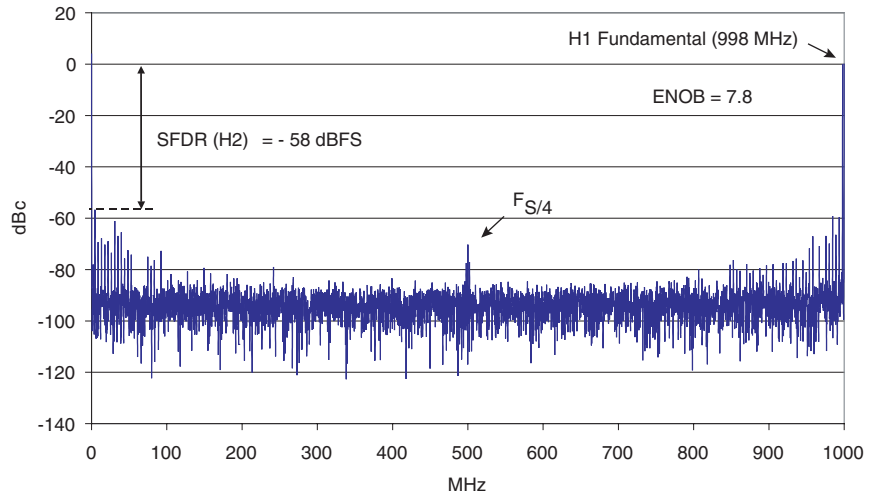
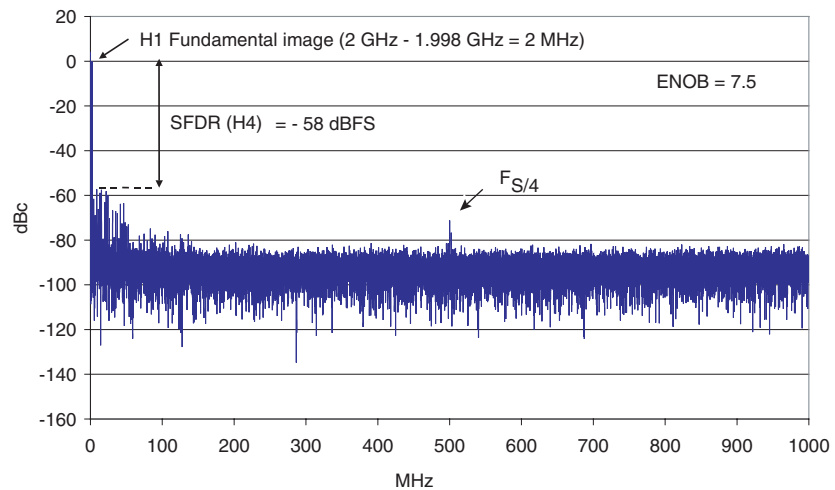

Figure 5-7. $F_s = 2$ Gsps, $F_{in} = 1998$ MHz -1 dBFS Analog Input, 1:4 Demultiplexing Factor, 32 kpoint FFT



5.8 Dynamic Performance Sensitivity Versus Temperature and Power Supply

Figure 5-8. Dynamic Parameters Versus Junction Temperature at $F_s = 2$ Gsps, $F_{in} = 998$ MHz, -1 dBFS Analog Input

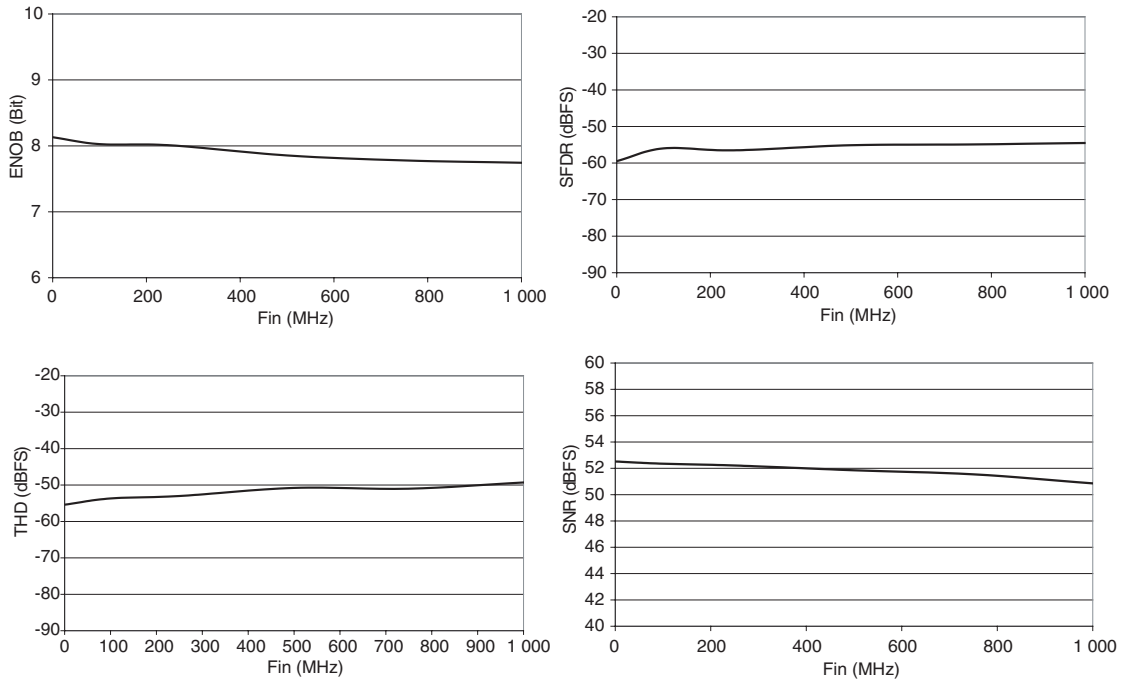
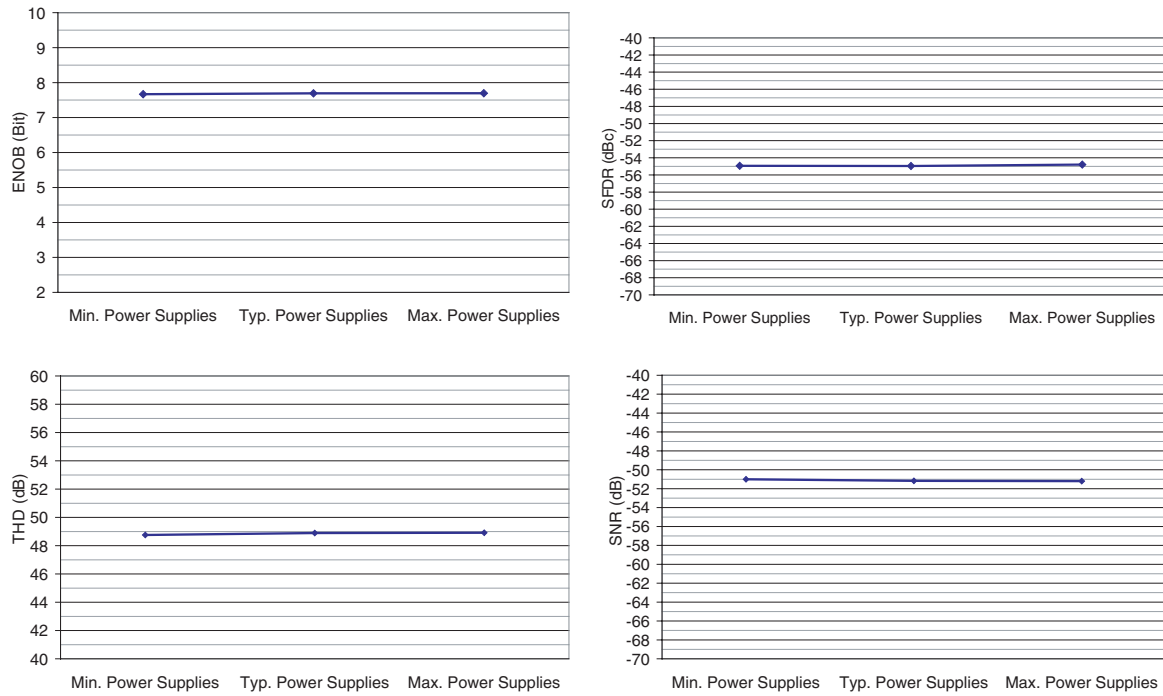

Figure 5-9. Dynamic Parameters at Min., Typ. and Max. Power Supplies, $F_s = 2$ Gsps, $F_{in} = 998$ MHz, -1 dBFS Analog Input



Note: Minimum power supplies: $V_{CC} = 3.45V$, $V_{EE} = -4.75V$
 Typical power supplies: $V_{CC} = 3.3V$, $V_{EE} = -5V$
 Maximum power supplies: $V_{CC} = 3.15V$, $V_{EE} = -5.25V$

5.9 Dual Tone Performance

Figure 5-10. Dual Tone Signal Spectrum at $F_s = 2$ Gsps, $F_{in1} = 1545$ MHz, $F_{in2} = 1555$ MHz (-7 dBFS)

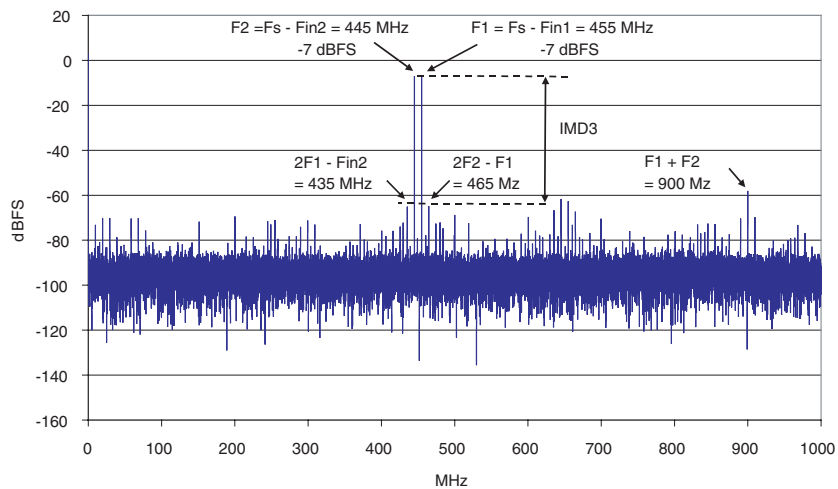

5.10 NPR Performance

Figure 5-11. Digitizing of 575 MHz Broadband Pattern at 1.4 Gsps, 25 MHz Notch Centered Around 290 MHz, -12 dBFS Loading Factor

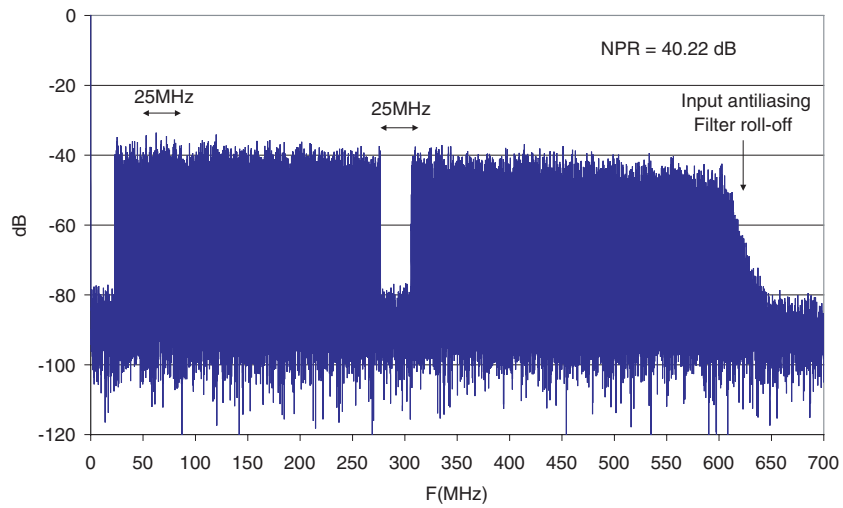

Table 6-1. Pin Description

Symbol	Pin Number	Function
Power Supplies		
DGND	C17, C18, D17, D18, F3, F4, H3, H4, M3, M4, P3, P4, R18, T18, U16, U17	Digital ground
AGND	B21, B23, C21, C23, D21, D23, E21, E23, F21, F23, F26, F27, G25, G26, G27, H25, H26, J25, J26, K27, N25, P25, R22, R23, R24, R25, R26, R27, T22, t23, T24, T25, T26, T27, U22, U23, U24, U25, U26, U27, V21, V23, V24, V26, V27, W22, W25, W26, W27	Analog ground
V _{CCA}	A24, A26, A27, B24, B26, B27, C24, C26, C27, D24, D26, D27, E24, E26, F25, L25, L26, M27, R21, T21, U21,	ADC analog positive power supply
V _{EE}	A25, B22, B25, C20, C22, C25, D20, D22, D25, E20; E22, E25, F20, F22, F24, K25, K26, L27, M25, M26, N26, N27, R20, T20	ADC analog negative power supply
SUB	D14, D15, R17	Connect to V _{EE}
V _{PLUSD}	C4, C5, C6, C7, C9, C11, C13, C14, C15, C16, C19, D5, D6, D7, D9, D11, D13, D19, E3, E19, F19, J3, J4, L3, L4, N3, N4, R3, R4, R19, T6, T7, T9, T11, T13, T14, T15, T19, U4, U5, U6, U7, U9, U11, U13, U14, U15	ADC and DMUX output power supply
V _{CCD}	C3, C8, C10, C12, D3, D4, D8, D10, D12, D16, E4, E17, G3, G4, K3, K4, R16, T3, T4, T5, T8, T10, T12, T16, T17, U3, U8, U10, U12	DMUX digital power supply
V _{MINUSD}	A19, A20, B19, B20, E18, F18, U19, U20	ADC digital negative power supply (-2.2V)
Inputs		
CLK, CLKN	H27, J27	ADC clock differential Inputs ECL/PECL/LVDS compatible
VIN	V25, W24	ADC in-phase analog input (double pin: one of the two has to be terminated via 50Ω to ground)
VINN	V22, W23	ADC Inverted-phase analog input (double pin: one of the two has to be terminated via 50Ω to ground)
Outputs		
A0...A9	B16, B15, B14, B13, B12, B11, B10, B9, B8, B7	In-phase digital outputs port A LVDS compatible
A0N...A9N	A16, A15, A14, A13, A12, A11, A10, A9, A8, A7	Inverted-phase digital outputs port A LVDS compatible
AOR/DRAN, AORN/DRA	B6, A6	Port additional bit or port A output clock in staggered mode

Table 6-1. Pin Description (Continued)

Symbol	Pin Number	Function
B0...B9	B5, B4, B3, B2, C2, D2, E2, F2, G2, H2	In-phase digital outputs port B LVDS compatible
B0N...B9N	A5, A4, A3, A2, B1, C1, D1, E1, F1, G1	Inverted-phase digital outputs port B LVDS compatible
BOR/DRBN, BORN/DRB	J2, H1	Port B additional bit or port B output clock in staggered mode
C0...C9	M2, N2, P2, R2, T2, U2, V1, V2, V3, V4	In-phase digital outputs port C LVDS compatible
C0N...C9N	L1, M1, N1, P1, R1, T1, U1, W2, W3, W4	Inverted-phase digital outputs port C LVDS compatible
COR/DRCN, CORN/DRC	V5, W5	Port C additional bit or port V output clock in staggered mode
D0...D9	V6, V7, V8, V9, V10, V11, V12, V13, V14, V15	In-phase digital outputs port D LVDS compatible
D0N...D9N	W6, W7, W8, W9, W10, W11, W12, W13, W14, W15	Inverted-phase digital outputs port D LVDS compatible
DOR/DRDN, DORN/DRD	V16, W16	Port D additional bit or port D output clock in staggered mode
DR, DRN	J1, K2	Differential output clock LVDS compatible
Control Functions Inputs		
DRRB	P27	ADC data ready reset LVCMOS (3.3V) compatible
ASYNCRST	B17	DMUX asynchronous reset
SDAEN	P26	ADC sampling delay adjust enable -SDA disabled when left floating or connected to ground -SDA enabled when connected to V_{EE}
SDA	E27	ADC sampling delay adjust ($\pm 0.5V$ range)
PGEB	A23	Pattern generator enable -Leave floating or connect to ground for normal mode -Connect to V_{EE} for test mode
B/GB	A21	Binary or gray output coding selection -Leave floating or connect to ground for binary coding -Connect to V_{EE} for gray coding
GA	W21	ADC gain adjust control pin ($\pm 0.5V$ range)
CLKTYPE	V18	Connect to V_{CCD}

Table 6-1. Pin Description (Continued)

Symbol	Pin Number	Function
SLEEP	A18	DMUX SLEEP mode Enable -leave floating or connect to V_{CCD} for normal mode -connect to ground for SLEEP mode
STAGG	A17	DMUX staggered mode enable -leave floating or connect to V_{CCD} for normal mode -connect to ground for STAGG mode
DRTYPE	K1	DMUX output clock mode selection -connect to ground for DR/2 type -leave floating or connect to V_{CCD} for DR type
RS	L2	DMUX Ratio mode selection -connect to ground for 1:2 ratio -leave floating or connect to V_{CCD} for 1:4 ratio
BIST	V17	DMUX BIST mode -leave floating or connect to V_{CCD} for normal mode -connect to ground for BIST mode
CLKDACTRL	U18	DMUX clock delay control (from $1/3 \times V_{CCD}$ to $2/3 \times V_{CCD}$)
DACTRL	W18	Standalone delay cell control (from $1/3 \times V_{CCD}$ to $2/3 \times V_{CCD}$)
DAEN	W17	Standalone delay cell enable -delay cell disabled when left floating or connected to V_{CCD} -delay cell enabled when connected to ground
DAI, DAIN	W19, V19	Standalone delay cell differential inputs LVDS compatible
Control Functions Outputs		
DAO, DAON	W20, V20	Standalone delay cell differential outputs LVDS compatible
DIODE ADC	A22	ADC die junction temperature monitoring
NC	A1, B18, W1	No connect (leave this pin floating)

7. Main Features

7.1 Reset

There are two reset signals available: DRRB and ASYNCRST. DRRB is active low while ASYNCRST is active high. These reset signals are required to start the device properly. It is recommended to apply both reset signals simultaneously. Please refer to the Application Section for more information on how to implement the reset functions. In the case of multiple channels, it is recommended to hold the input clock signal low during reset (as described in [Figure 7-1](#)) to ensure synchronization of the channels.

The DRRB/ASYNCRST signal frequency should be 200 MHz maximum. The reset pulse should be 1 ns minimum.

Figure 7-1. Asynchronous Reset Timing Diagram, 1:2 Mode, Simultaneous Mode (Principle of Operation)

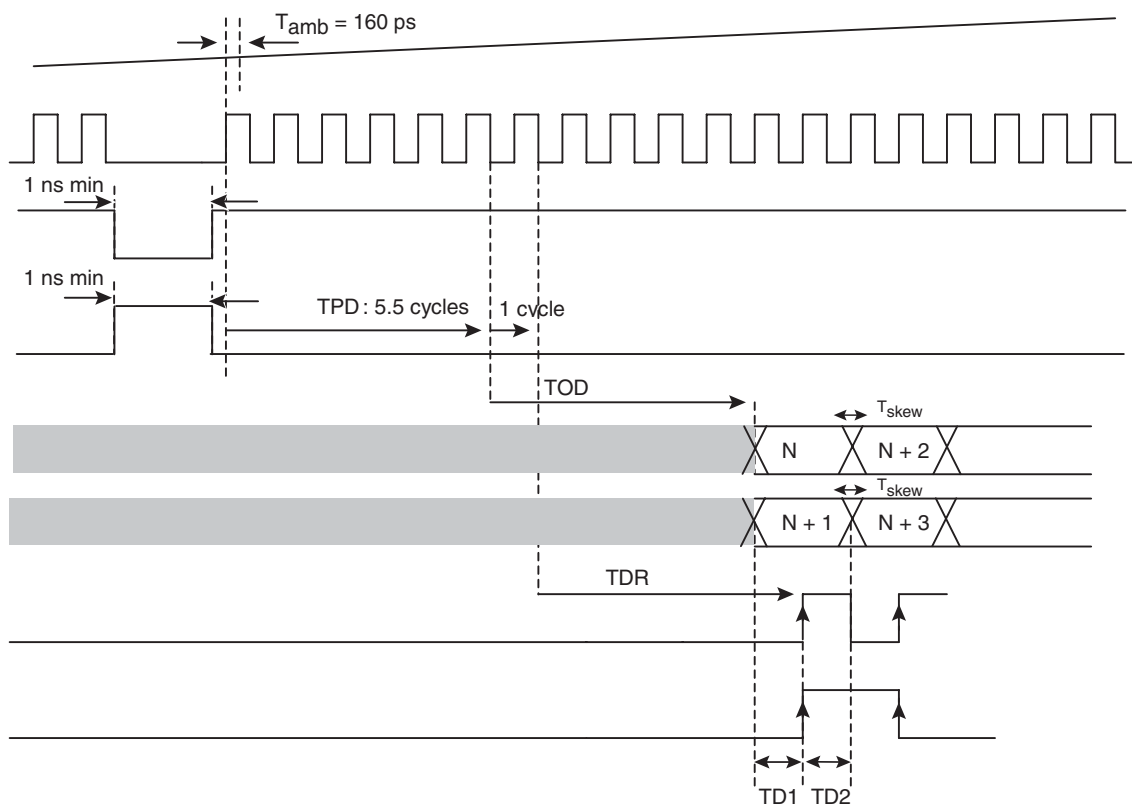
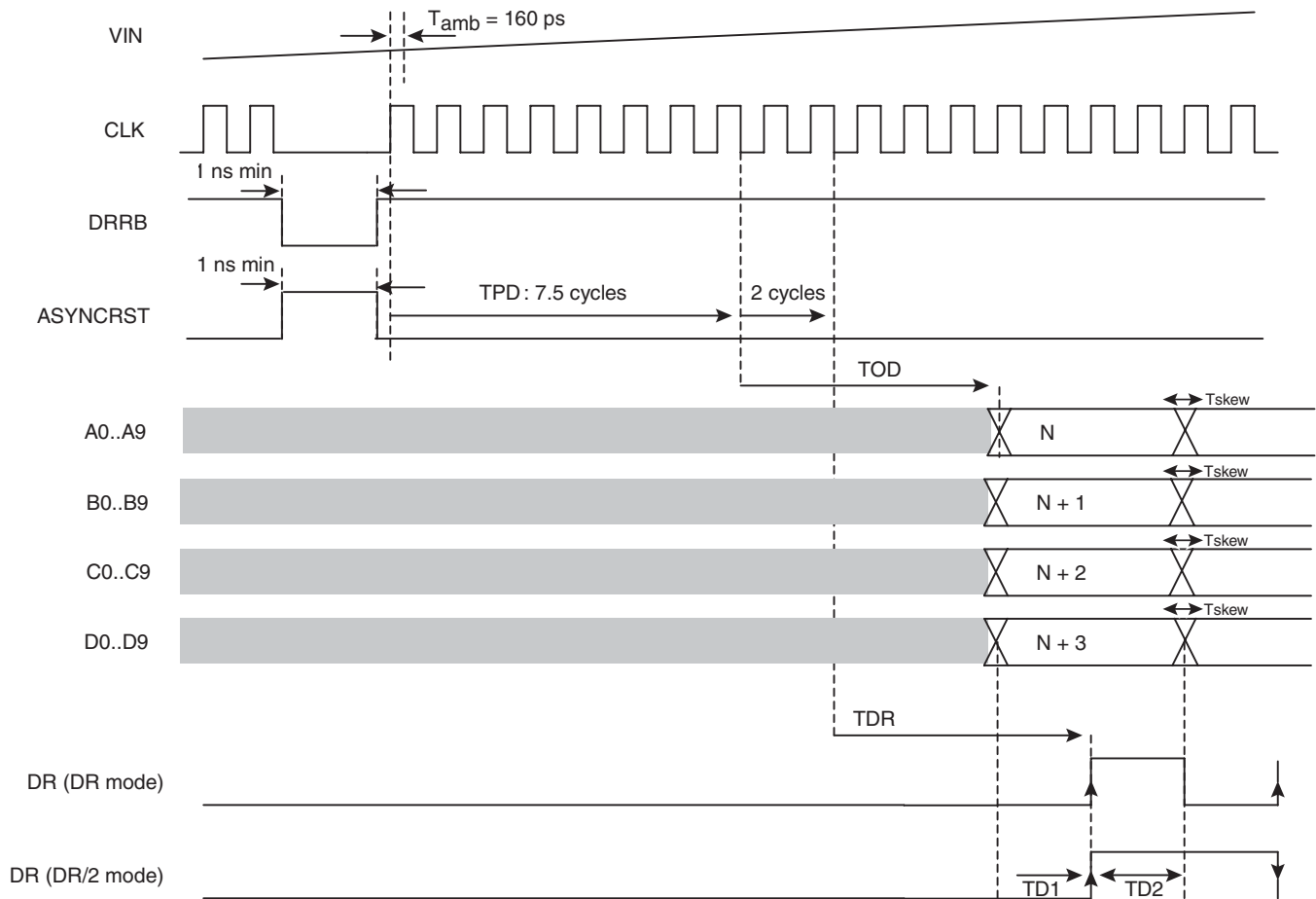

Figure 7-2. Asynchronous Reset Timing Diagram, 1:4 Mode, Simultaneous Mode (Principle of Operation)



- Note:
1. TPD time is the delay between the first rising edge after the reset signal and before the TOD or TDR delay. This time is a number of clock cycle.
 2. Definition of TOD: it is the time between the falling edge and the next point of change of data
 3. Definition of TDR: it is the time between the falling edge and the next point of change of data ready.
 4. $TOD - TDR$ is always lower to 600 ps over temperature and power supply
 5. $TD1 = 2 \text{ clock cycles} + TOD - TDR$.
 6. $TD2 = 2 \text{ clock cycles} + TDR - TOD$ With $TOD = 6.2 \text{ ns}$. This delay is long due to the several delay lines in the DMUX.

7.2 Control Signal Settings

The SLEEP, RS, DAEN, STAGG, BIST and DRTYPE control signals use the same static buffer.

ASYNCRST is activated on logic high (tied/switched to $V_{CCD} = 3.3V$, or $10\text{ k}\Omega$ to ground, or left floating) and deactivated on logic low (grounded).

SLEEP, DAEN, STAGG, BIST are activated on logic low (10Ω grounded), and deactivated on logic high ($10\text{ k}\Omega$ to ground, or tied to $V_{CCD} = 3.3V$, or left floating). This is illustrated in [Figure 7-3](#).

Figure 7-3. Control Signal Setting

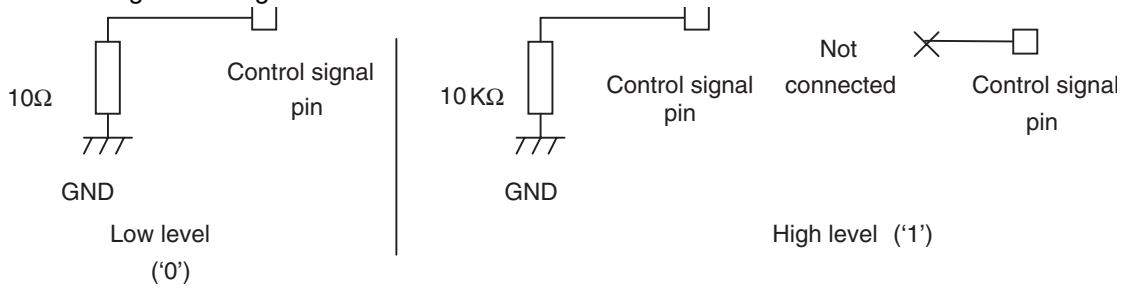

Table 7-1. DMUX Mode Settings - Summary

Function	Logic Level	Electrical Level	Description
BIST	0	10 Ω to ground	BIST
	1	10 k Ω to ground	Normal conversion
		N/C	
SLEEP	0	10 Ω to ground	Power reduction mode (the outputs are fixed at an arbitrary LVDS level)
	1	10 Ω to ground	Normal conversion
		N/C	
STAGG	0	10 Ω to ground	Staggered mode
	1	10 k Ω to ground	Simultaneous mode
		N/C	
DAEN	0	10 Ω to ground	Standalone delay adjust activated
	1	10 k Ω to ground	Standalone delay adjust disabled
		N/C	
RS	0	10 Ω to ground	1:2 ratio
	1	10 k Ω to ground	1:4 ratio
		N/C	
ASYNCRST	0	10 Ω to ground	Normal conversion
	1	10 k Ω to ground	Reset
		N/C	
DRTYPE	0	10 Ω to ground	DR/2 mode
	1	10 k Ω to ground	DR mode
		N/C	

7.3 Programmable DMUX Ratio

The demultiplexer ratio is programmable thanks to the RS ratio selection signal:

RS	DMUX Ratio
0	1:2
1	1:4

Figure 7-4. DMUX in 1:2 Ratio

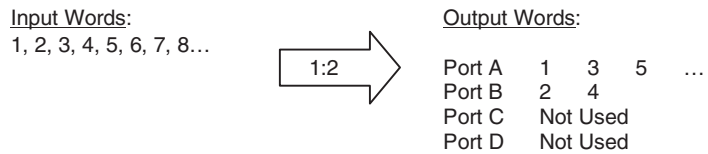
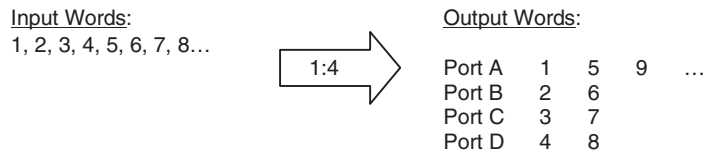

Figure 7-5. DMUX in 1:4 Ratio



7.4 Output Mode (STAGG)

Two output mode are provided:

- Staggered: the output data come out of the DMUX the one after the other;
- Simultaneous: the output data come out of the DMUX at the same time.

In staggered mode, the output clock for each port is provided by the DRA, DRAN, DRB, DRBN, DRC, DRCN and DRD, DRDN signals which corresponds respectively to the AORN, AOR, BRON, BOR, CORN, COR, DORN and DOR.

The simultaneous mode is the default mode (STAGG left floating of at logic 1).

The staggered mode is activated by the means of the STAGG input (active low).

Figure 7-6. Simultaneous Mode in 1:4 Ratio (STAGG = 1)

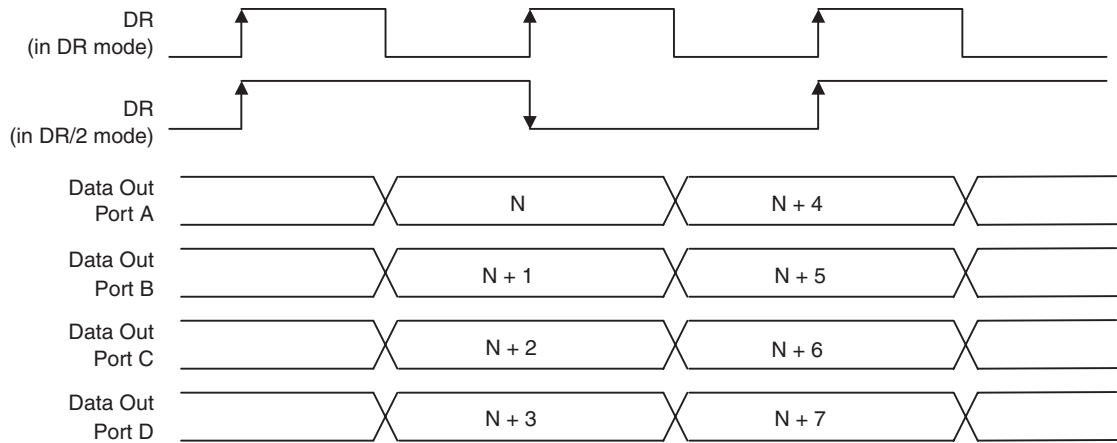

Figure 7-7. Staggered Mode in 1:2 Ratio (STAGG = 0)

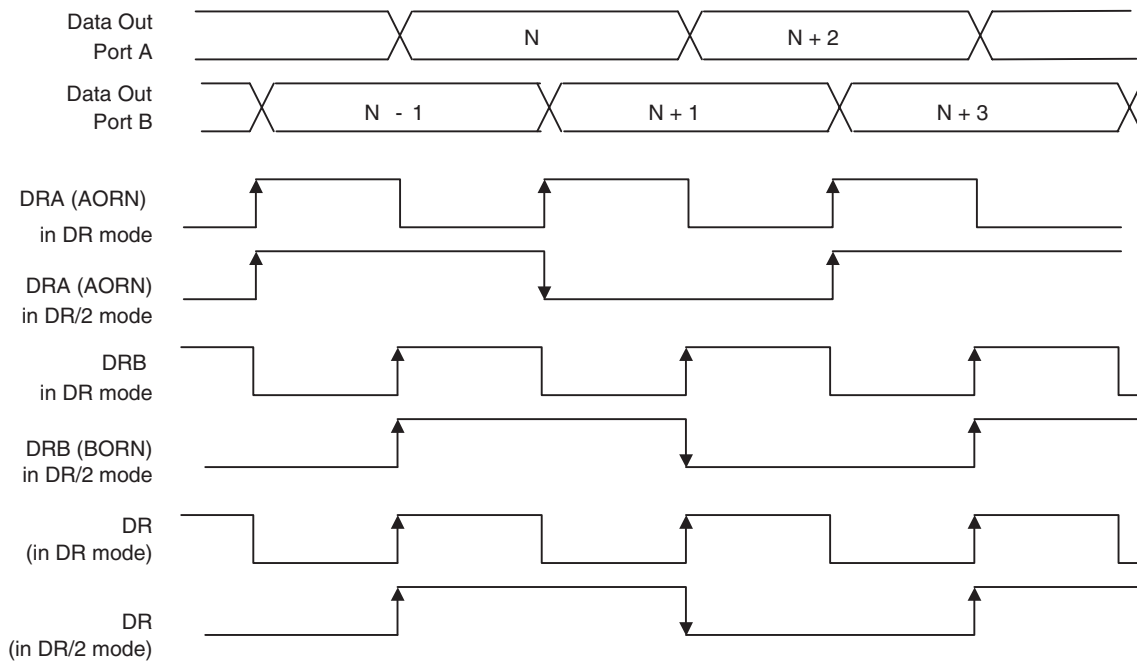
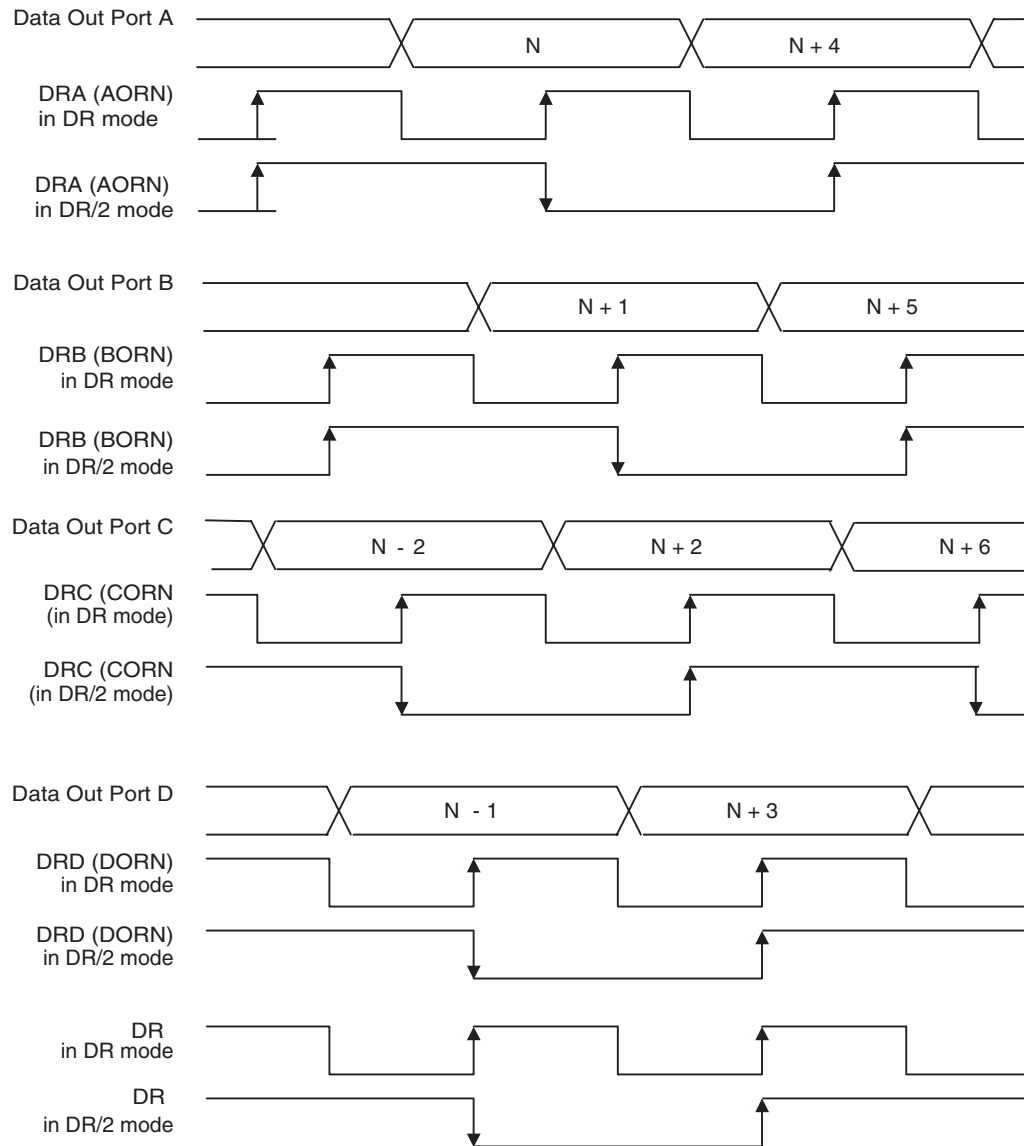

Figure 7-8. Staggered Mode in 1:4 Ratio (STAGG = 0)



7.5 Additional Bit

In simultaneous output mode:

The (AOR/DRAN, AORN/DRA), (BOR/DRBN, BORN/DRB), (COR/DRCN, CORN/DRC) and (DOR/DRDN, DORN/DRD) signals are used to process the out-of-range bit from the ADC as the ADC output data.

In 1:2 ratio, (AOR, AORN) and (BOR, BORN) will output this signal at half its initial speed.

In 1:4 ratio, (AOR, AORN), (BOR, BORN), (COR, CORN) and (DOR, DORN) will output this signal at 1/4 of its initial speed.

In Staggered output mode: (AOR/DRAN, AORN/DRA), (BOR/DRBN, BORN/DRB), (COR/DRCN, CORN/DRC) and (DOR/DRDN, DORN/DRD) will output a Data Ready signal for each ports, centered on the corresponding data.

The frequency of the (DRA, DRAN), (DRB, DRBN), (DRC, DRCN) and (DRD, DRDN) depends on the DRTYPE mode (same as data in DR mode, half in DR/2 mode).

In 1:2 ratio, DR/DRN and DRB/DRBN are the same.

In 1:4 ratio, DR/DRN and DRD/DRDN are the same.

7.6 Output Clock Type Selection

Two modes for the output clock type can be chosen:

- DR mode: only the output clock rising edge is active, the output clock rate is the same as the output data rate;
- DR/2 mode: both the output clock rising and falling edges are active, the output clock rate is half the output data rate.

This is illustrated in [Figure 7-9](#) and [Figure 7-10](#).

Figure 7-9. DR Mode

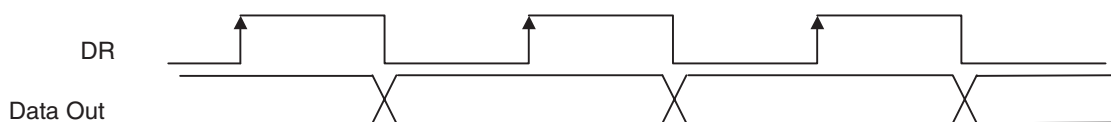

Figure 7-10. DR/2 Mode

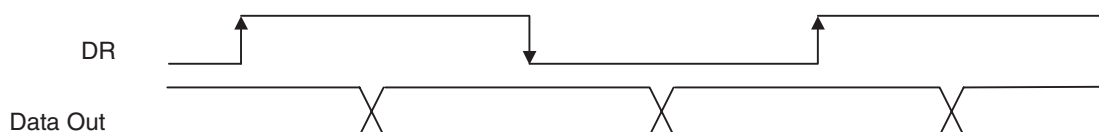

Table 7-2. Table 8. DMUX Output Clock Type Selection Settings

DRTYPE	DMUX Output Clock Type
1	DR
0	DR/2

When DRTYPE is left floating, the default mode is DR.

7.7 Power Reduction Mode (SLEEP)

The power reduction (SLEEP) mode allows the user to reduce the power consumption of the device (demultiplexing part in Sleep mode). In this mode, the device's consumption is reduced to 5W. The Power reduction mode is active when SLEEP is low. The device is in normal mode when SLEEP is high.

7.8 Standalone Delay Cell

A standalone delay cell is provided to allow the user to add a delay on the DAI/DAIN differential input signal. The delay is controlled via the DACTRL. The tuning range is about 550 ps varying from $V_{CCD} / 3$ to $(2 \times V_{CCD}) / 3$. This function results in a delayed output signal: DAO/DAON. The DAI/DAIN and DAO/DAON are LVDS signals.

Figure 7-11. Standalone Delay Cell Block Diagram

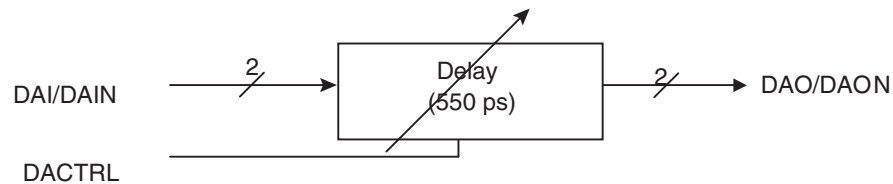

7.9 Clock input Delay Cell

A delay cell is provided to allow the user to tune the delay between clock and data at the DEMUX input. The delay is controlled via the CLKDACTRL. It ranges from -275 ps to 275 ps for CLKDACTRL varying from $V_{CCD} / 3$ to $(2 \times V_{CCD}) / 3$.

This function results in a delayed internal clock signal.

Figure 7-12. Standalone Delay Cell Block Diagram

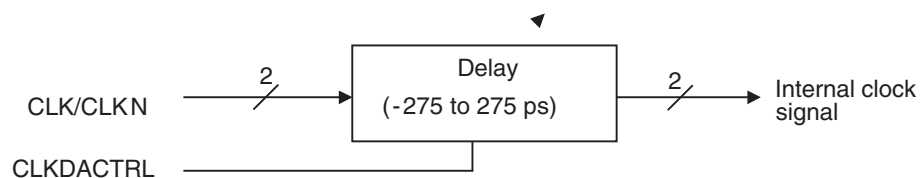

7.10 Built-In Self Test

The Built-in Self Test allows to test rapidly the DMUX block of the device. It is activated via the BIST bit (active low). When this signal is left floating, the BIST is inactive.

When in BIST mode, a clock must be applied to the device, which can be set to 1:2 or 1:4 mode. The output clock mode DRTYPE can be either DR or DR/2. In the BIST mode, all the bits are either all at low or high level (even and odd bits are in phase opposition) and transition every new cycle. For proper operation of the Built-In Self Test, V_{CCD} should be set to 3.3V minimum.

7.11 ADC Die Junction Temperature Monitoring

A die junction temperature measurement setting is available, for maximum junction temperature monitoring (hot point measurement). The measurement method consists in forcing a 1 mA current into a diode mounted transistor and sensing the voltage across the DIODE pin and the closest available ground pin. The measurement setup is described in [Figure 7-13 on page 34](#).

Figure 7-13. ADC Diode for Die Junction Temperature Monitoring Setup (10 in parallel of 3)

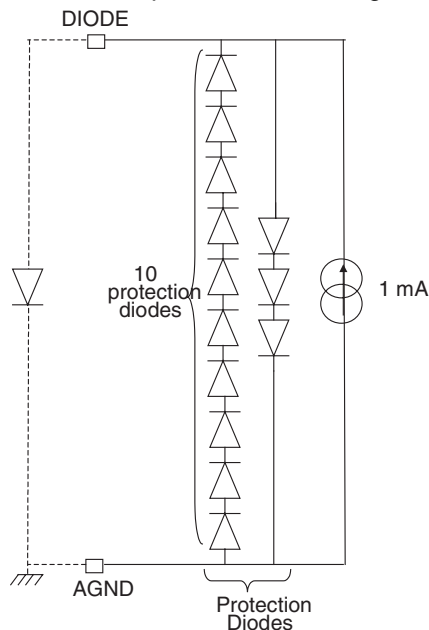

Caution:

Respect the current source polarity. In all cases, make sure that the maximum voltage compliance of the current source is limited to a maximum of 1V or use a resistor mounted in series with the current source to avoid damages, which may occur to the transistor device (this may occur for instance if the current source is connected in reverse).

The diode VBE forward voltage versus junction temperature (in steady state conditions) characteristic is given in Figure 7-14. The forward voltage drop, (V_{DIODE}) across diode component, versus junction temperature, (including chip parasitic resistance), is given below ($I_{DIODE} = 1 \text{ mA}$).

Figure 7-14. ADC Diode Characteristic ($I = 1 \text{ mA}$)

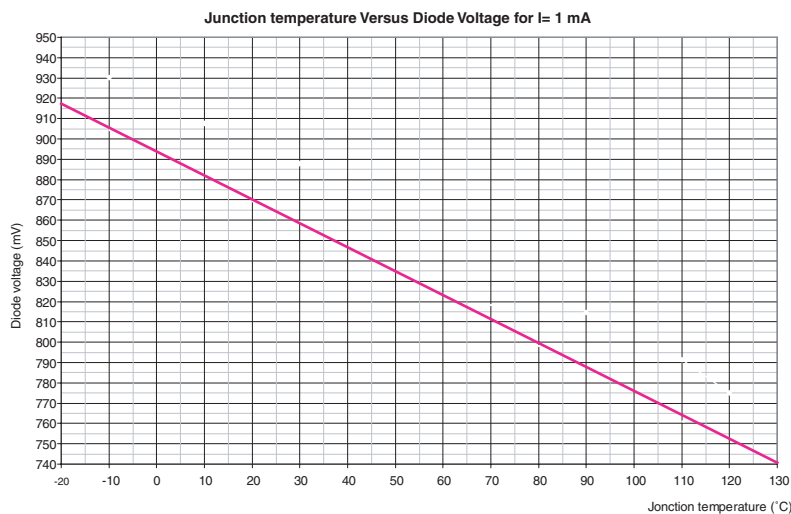

Note: The operating die junction temperature must be kept below 125°C, to ensure long term device reliability.

7.12 Pattern Generator Function

The Pattern Generator function (enabled by connecting pin PGEB to $V_{EE} = -5V$) allows to check rapidly the ADC operation thanks to a checker board pattern delivered internally to the ADC. Each output bit of the ADC should toggle from 0 to 1 successively. At the AT84AS004 output, all bits of each port are all 1 or all 0 and transition every cycle.

7.13 ADC Gain Control

The ADC gain is adjustable by the means of the pin W21 of the EPGA package.

The gain adjust transfer function is given below:

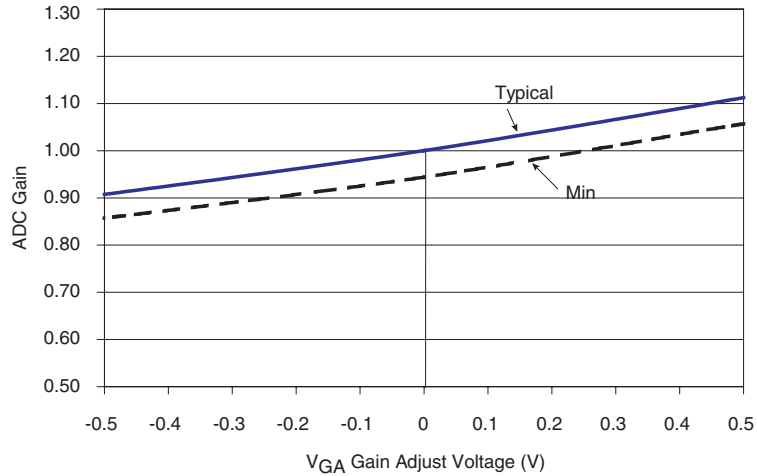

7.14 Sampling Delay Adjust

Sampling delay adjust (SDA pin) allows to fine tune the sampling ADC aperture delay TAD around its nominal value (160ps). This functionality is enabled thanks to the SDAEN signal, which is active when tied to V_{EE} and inactive when tied to GND.

This feature is particularly interesting for interleaving ADCs to increase sampling rate. The variation of the delay around its nominal value as a function of the SDA voltage is shown in the following graph (simulation result):

Figure 7-15. Typical Tuning Range is ± 120 ps for Applied Control Voltage Varying Between -0.5V to 0.5V on SDA pin.

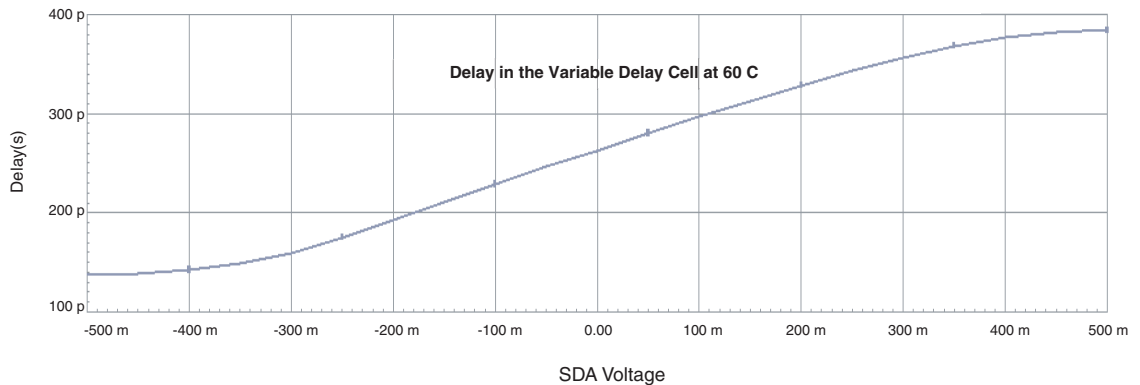

Note: The variation of the delay in function of the temperature is negligible.

8. Equivalent Input/Output Schematics

8.1 Equivalent Analog Input Circuit and ESD Protection

Figure 8-1. AT84AS004 Analog Input Buffer Schematic (VIN/VINN)

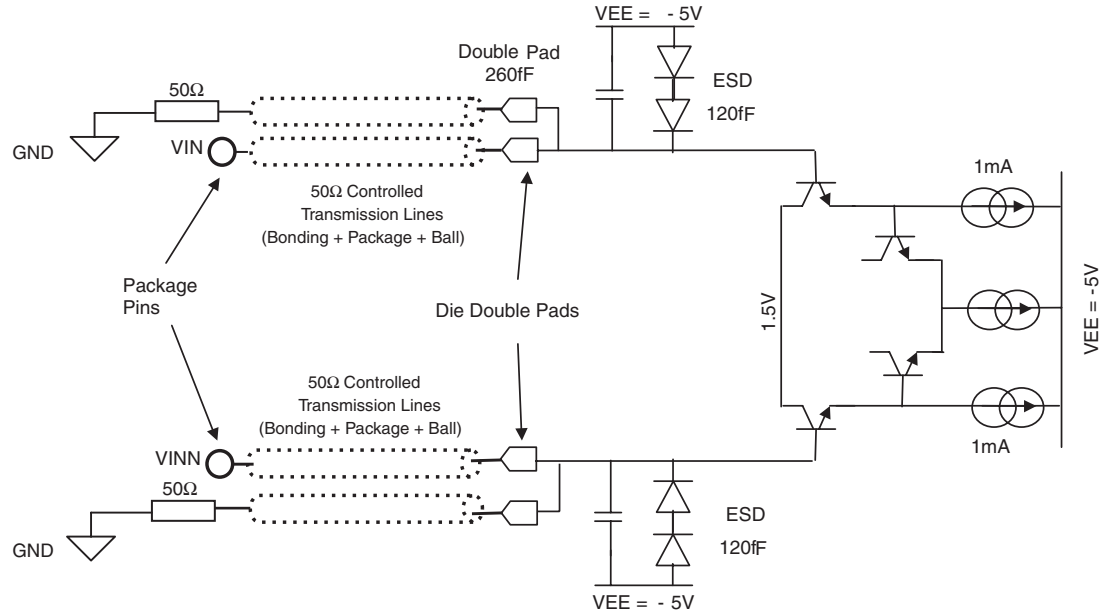

Note: External 50Ω reverse termination are required.

8.2 Equivalent Clock Input Circuit and ESD Protection

Figure 8-2. AT84AS004 Clock Input Buffer Schematic (CLK/CLKN)

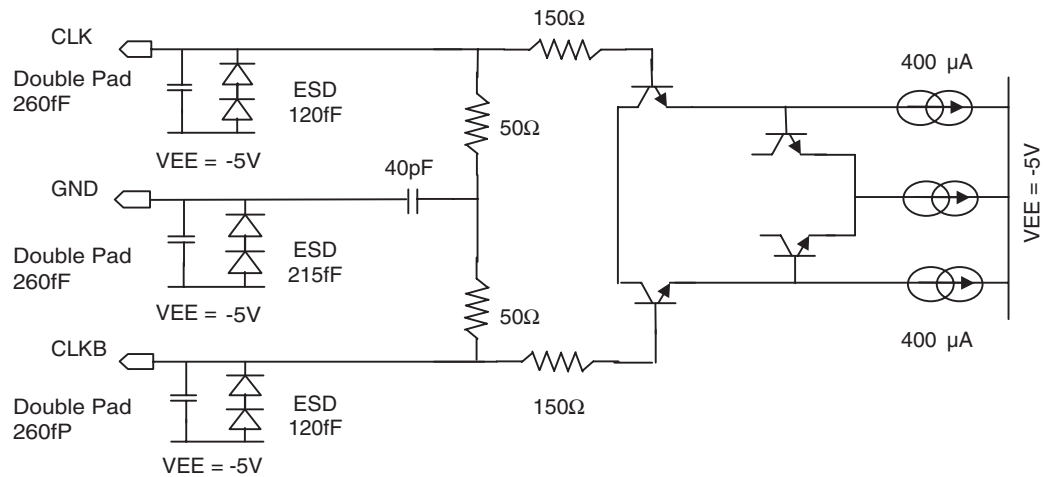

Note: The 100Ω termination mid point is on chip and AC coupled to ground through a 40 pF capacitor.

8.3 Equivalent Data/Clock Output Buffer Circuit and ESD Protection

Figure 8-3. AT84AS004 Data (Ai/AiN...Di/DiN), Clock (DR/DRN) and DAO/DAON Output Buffer Schematic

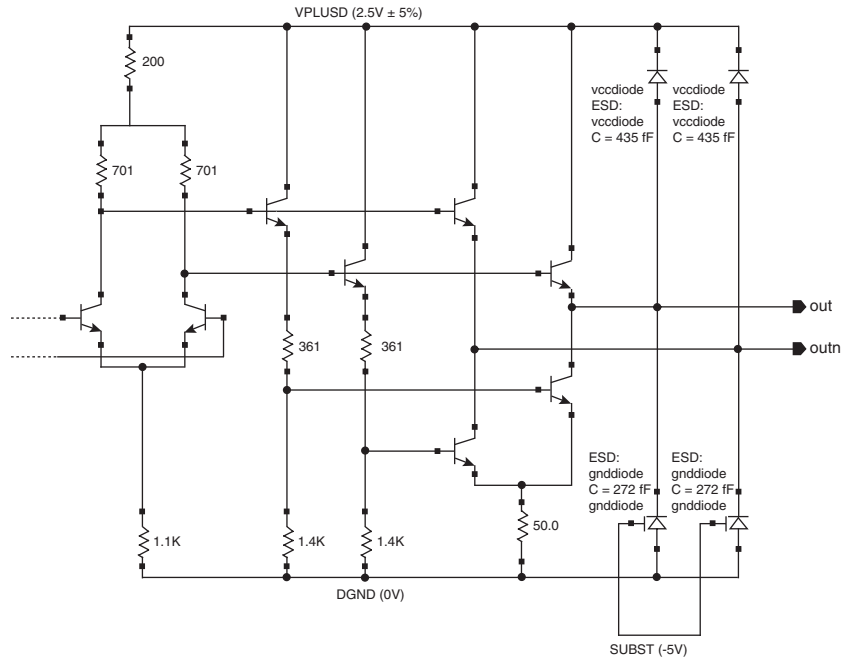

8.4 Standalone Delay Cell Data Input (DAI/DAIN) Buffer Circuit and ESD Protection

Figure 8-4. AT84AS004 Standalone Delay Cell Input DAI/DAIN Buffer Schematic

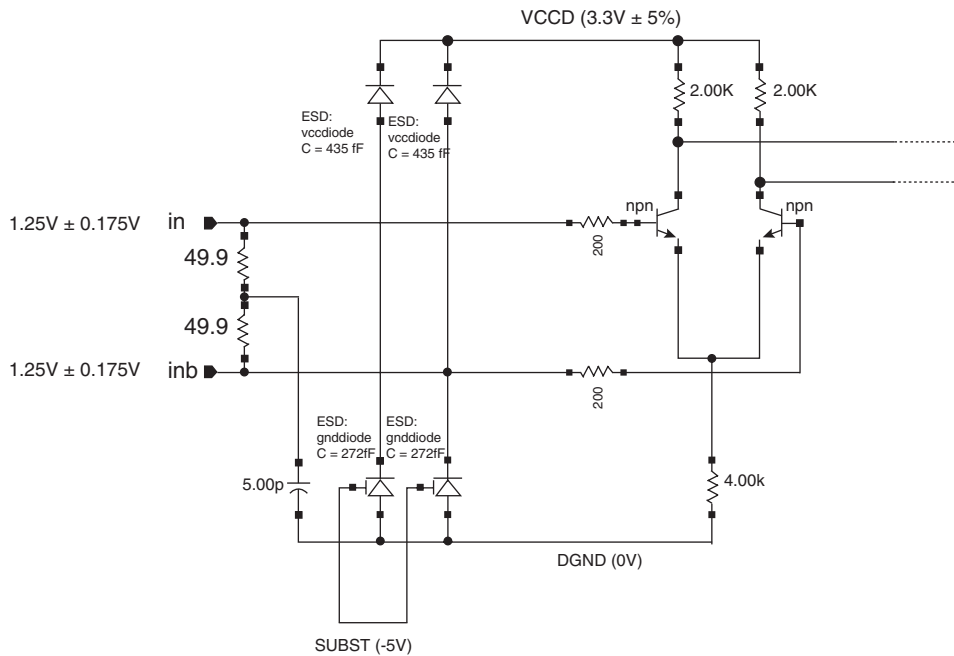

8.5 Delay Cell (DACTRL/DACTRLN and CLKCTRL/CLKCTRLN) Control Input Schematic and ESD Protection

Figure 8-5. AT84AS004 Delay Cell Control Input DACTRL/DACTRLN and CLKCTRL/CLKCTRLN Buffer Schematic

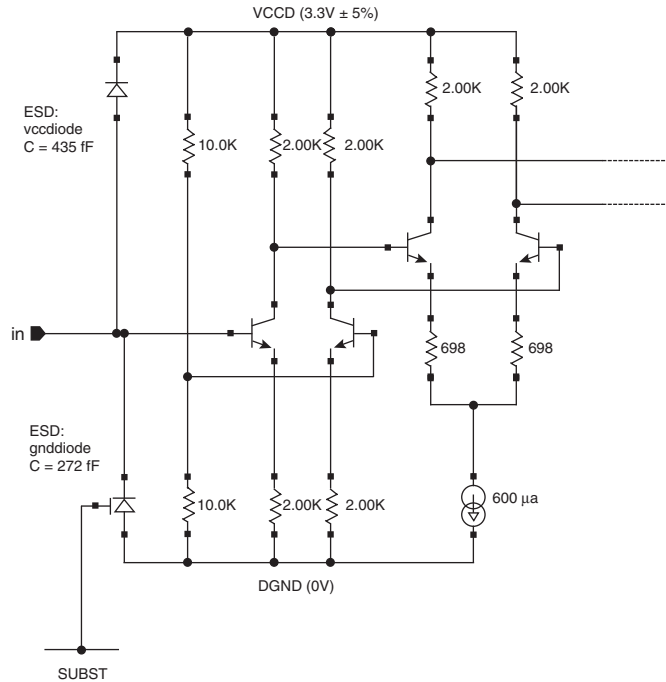

8.6 DRRB Equivalent Input Schematic and ESD Protection

Figure 8-6. AT84AS004 DRRB Reset Input Buffer Schematic

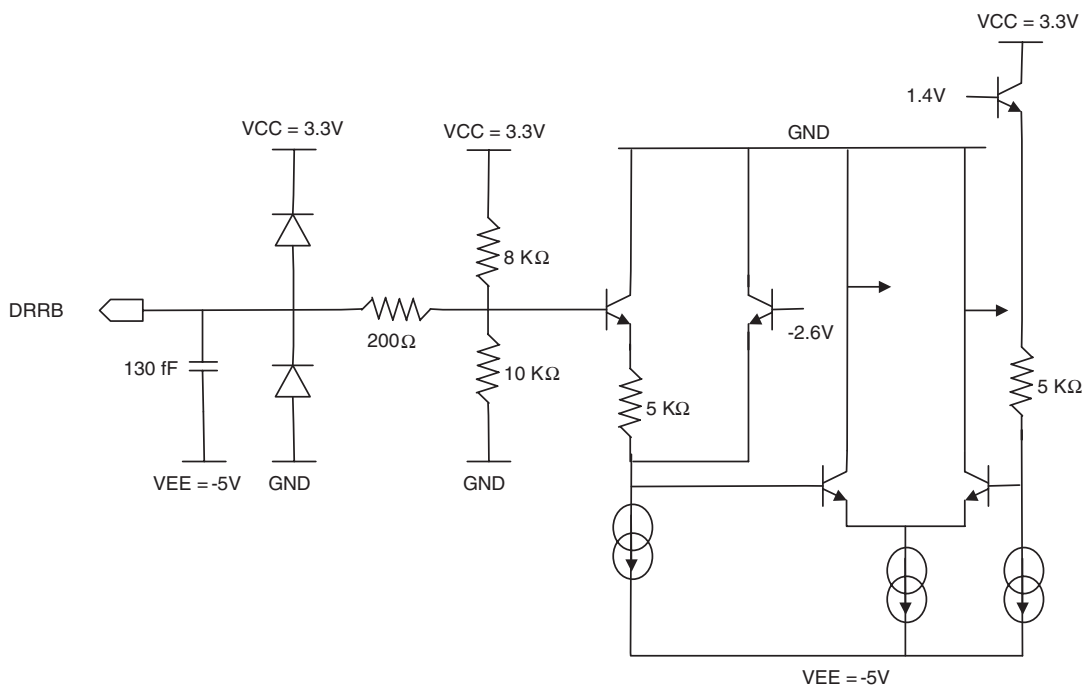

8.7 ASYNCRST Equivalent Input Schematic and ESD Protection

Figure 8-7. AT84AS004 Asynchronous Reset ASYNCRST Buffer Schematic

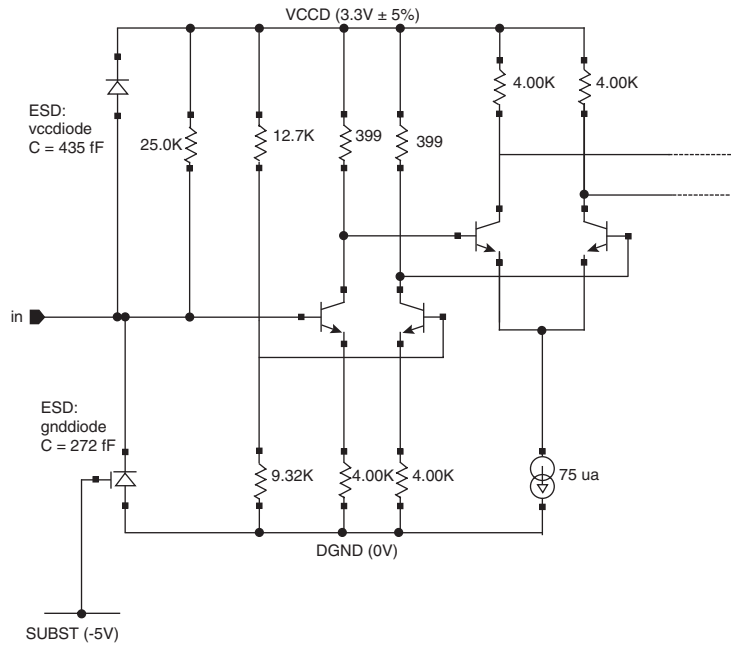

8.8 ADC Gain Adjust Equivalent Input Circuits and ESD Protection

Figure 8-8. AT84AS004 Gain Adjust Control Input Buffer Schematic (GA)

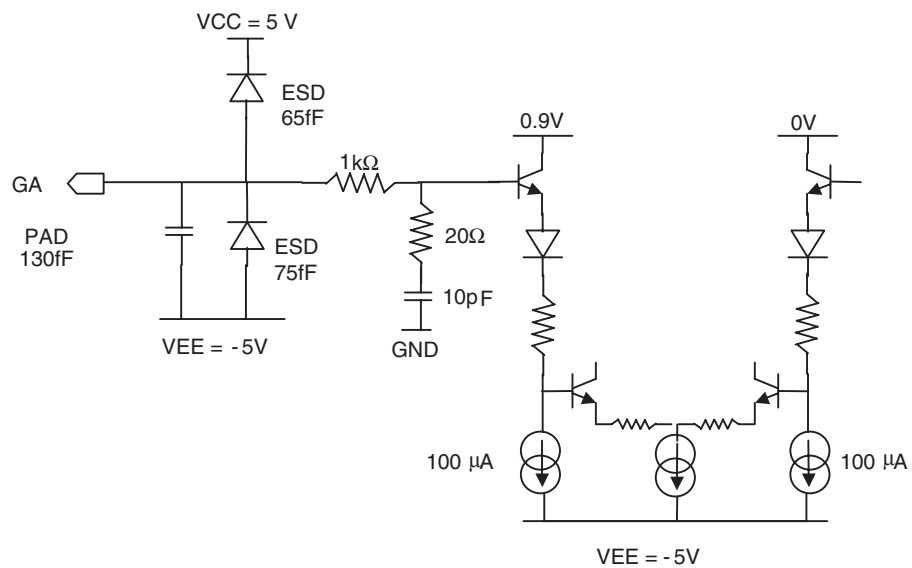

8.9 B/GB and PGEB Equivalent Input Schematics and ESD Protection

Figure 8-9. AT84AS004 B/GB and PGEB Control Buffer Schematic

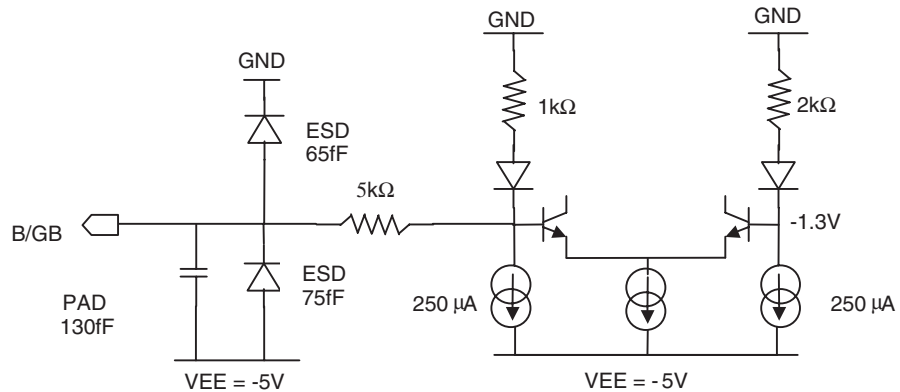

8.10 Control Signals Input Buffers and ESD Protection

Figure 8-10. AT84AS004 Control Signals Buffer Schematic (RS, DRTYPE, BIST, SLEEP, STAGG, RS, DAEN)

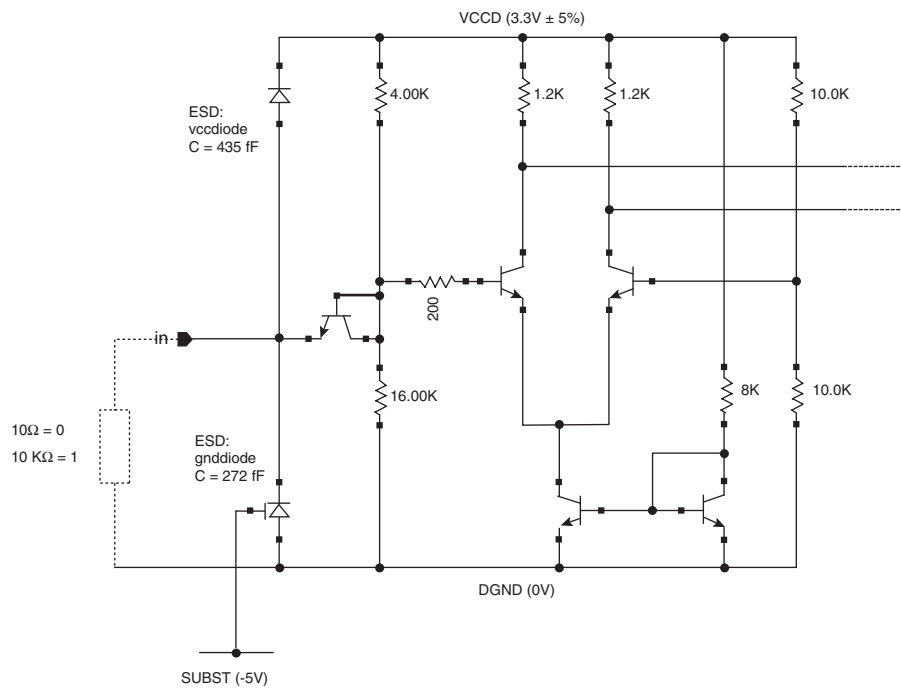

9. Definitions of Terms

(Fs max)	Maximum Sampling Frequency	Sampling frequency for which ENOB < 6bit.s
(Fs min)	Minimum Sampling frequency	Sampling frequency for which the ADC Gain has fallen by 0.5 dB with respect to the gain reference value. Performances are not guaranteed below this frequency.
(BER)	Bit Error Rate	Probability to exceed a specified error threshold for a sample at maximum specified sampling rate. An error code is a code that differs by more than ± 4 LSB from the correct code.
(FPBW)	Full Power Input Bandwidth	Analog input frequency at which the fundamental component in the digitally reconstructed output waveform has fallen by 3 dB with respect to its low frequency value (determined by FFT analysis) for input at full-scale -1 dB (-1 dBFS).
(SSBW)	Small Signal Input Bandwidth	Analog input frequency at which the fundamental component in the digitally reconstructed output waveform has fallen by 3 dB with respect to its low frequency value (determined by FFT analysis) for input at full-scale -10 dB (-10 dBFS).
(SINAD)	Signal to Noise and Distortion Ratio	Ratio expressed in dB of the RMS signal amplitude, set to 1 dB below full-scale (-1 dBFS), to the RMS sum of all other spectral components, including the harmonics except DC.
(SNR)	Signal to Noise Ratio	Ratio expressed in dB of the RMS signal amplitude, set to 1dB below full-scale, to the RMS sum of all other spectral components excluding the twenty five first harmonics.
(THD)	Total Harmonic Distortion	Ratio expressed in dB of the RMS sum of the first twenty five harmonic components, to the RMS input signal amplitude, set at 1 dB below full-scale. It may be reported in dB (i.e, related to converter -1 dB full-scale), or in dBc (i.e, related to input signal level).
(SFDR)	Spurious Free Dynamic Range	Ratio expressed in dB of the RMS signal amplitude, set at 1 dB below full-scale, to the RMS value of the highest spectral component (peak spurious spectral component). The peak spurious component may or may not be a harmonic. It may be reported in dB (i.e., related to converter -1 dB full-scale), or in dBc (i.e, related to input signal level).
(ENOB)	Effective Number of Bits	$ENOB = \frac{SINAD - 1.76 + 20 \log \frac{A}{FS/2}}{6.02}$ <p>Where A is the actual input amplitude and V is the full-scale range of the ADC under test.</p>
(DNL)	Differential Non-Linearity	The Differential Non Linearity for an output code i is the difference between the measured step size of code i and the ideal LSB step size. DNL (i) is expressed in LSBs. DNL is the maximum value of all DNL (i). DNL error specification of less than 1 LSB guarantees that there are no missing output codes and that the transfer function is monotonic.
(INL)	Integral Non-Linearity	The Integral Non Linearity for an output code i is the difference between the measured input voltage at which the transition occurs and the ideal value of this transition. INL (i) is expressed in LSBs, and is the maximum value of all INL (i).
(TA)	Aperture Delay	Delay between the rising edge of the differential clock inputs (CLK,CLKB) (zero crossing point), and the time at which (VIN,VINB) is sampled.

(JITTER)	Aperture Uncertainty	Sample to sample variation in aperture delay. The voltage error due to jitter depends on the slew rate of the signal at the sampling point.
(TS)	Settling Time	Time delay to achieve 0.2 % accuracy at the converter output when a 80% full-scale step function is applied to the differential analog input.
(ORT)	Over Voltage Recovery Time	Time to recover 0.2% accuracy at the output, after a 150 % full-scale step applied on the input is reduced to midscale.
(TOD)	Digital Data Output Delay	Delay from the rising edge of the differential clock inputs (CLK,CLKB) (zero crossing point) to the next point of change in the differential output data (zero crossing) with specified load.
(TDR)	Data Ready Output Delay	Delay from the falling edge of the differential clock inputs (CLK,CLKB) (zero crossing point) to the next point of change in the differential output data (zero crossing) with specified load.
(TD1)	Time Delay from Data Transition to Data Ready	General expression is $TD1 = TC1 + TDR - TOD$ with $TC = TC1 + TC2 = 1$ encoding clock period.
(TD2)	Time delay from Data Ready to Data	General expression is $TD2 = TC2 + TDR - TOD$ with $TC = TC1 + TC2 = 1$ encoding clock period.
(TC)	Encoding Clock Period	$TC1 =$ Minimum clock pulse width (high) $TC = TC1 + TC2$ $TC2 =$ minimum clock pulse width (low).
(TPD)	Pipeline Delay	Number of clock cycles between the sampling edge of an input data and the associated output data being made available, (not taking in account the TOD).
(TR)	Rise Time	Time delay for the output DATA signals to rise from 20% to 80% of delta between low level and high level.
(TF)	Fall Time	Time delay for the output DATA signals to fall from 20% to 80% of delta between low level and high level.
(PSRR)	Power Supply Rejection Ratio	Ratio of input offset variation to a change in power supply voltage.
(NRZ)	Non Return to Zero	When the input signal is larger than the upper bound of the ADC input range, the output code is identical to the maximum code and the out-of-range bit is set to logic one. When the input signal is smaller than the lower bound of the ADC input range, the output code is identical to the minimum code, and the out-of-range bit is set to logic one. (It is assumed that the input signal amplitude remains within the absolute maximum ratings).
(IMD)	Inter modulation distortion	The two tones inter modulation distortion (IMD) rejection is the ratio of either input tone to the worst third order intermodulation products.
(NPR)	Noise Power Ratio	The NPR is measured to characterize the ADC performance in response to broad bandwidth signals. When applying a notch-filtered broadband white-noise signal as the input to the ADC under test, the Noise Power Ratio is defined as the ratio of the average out-of-notch to the average in-notch power spectral density magnitudes for the FFT spectrum of the ADC output sample test.
(VSWR)	Voltage Standing Wave Ratio	The VSWR corresponds to the ADC input insertion loss due to input power reflection. For example a VSWR of 1.2 corresponds to a 20 dB return loss (i.e.. 99% power transmitted and 1% reflected).

10. Thermal and Moisture Characteristics

As there is no JEDEC standard definition for the thermal resistance applied to a multi-die device, only the thermal resistance for each die (ADC block powered on only or DMUX block powered on only) is provided. For easy understanding of the thermal behavior of the device, thermal data with both devices powered on are however provided.

All results were computed with ANSYS thermal simulation tool and with the following assumptions:

- Half geometry simulation
- DC heating zone = $1.9 \times 1.9 \text{ mm}^2$
- MUX heating $4.0 \times 4.0 \text{ mm}^2$
- No air, pure conduction, no radiation

10.1 Thermal Resistance from Junction To Bottom of Balls

When both blocks are powered on, the thermal simulation results in:

- Temperature at the center of the ADC block = 32.9°C
- Temperature at the center of the DMUX block = 13.6°C

When each block is powered on at a time, the resulting thermal resistance from junction to bottom of balls is:

- Rth Junction-bottom of balls (ADC block on only) = 7°C/W
- Rth Junction-bottom of balls (DMUX block on only) = 3.9°C/W

10.2 Thermal Resistance from Junction To Top of Case

When both blocks are powered on, the resulting thermal resistance from junction to top of case is:

- Temperature at the center of the ADC block = 18.5°C
- Temperature at the center of the DMUX block = 4.1°C

When each block is powered on at a time, the resulting thermal resistance from junction to top of case is:

- Rth Junction- top of case (ADC block on only) = 4.1°C/W
- Rth Junction- top of case (DMUX block on only) = 1.5°C/W

10.3 Thermal Resistance from Junction To Board

When both blocks are powered on, the resulting thermal resistance from junction to board is:

- Temperature at the center of the ADC block = 57.6°C
- Temperature at the center of the DMUX block = 37.3°C

When each block is powered on at a time, the resulting thermal resistance from junction to board is:

- Rth Junction- board (ADC block on only) = 8°C/W
- Rth Junction- board (DMUX block on only) = 4.9°C/W

Note: Assumed board size = $53 \times 43 \text{ mm}^2$

10.4 Thermal Resistance from Junction To Ambient

When both blocks are powered on, the resulting thermal resistance from junction to ambient is:

- Temperature at the center of the ADC block = 106°C
- Temperature at the center of the DMUX block = 85.3°C

When each block is powered on at a time, the resulting thermal resistance from junction to ambient is:

- Rth Junction- ambient (ADC block on only) = 17.1°C/W
- Rth Junction- ambient (DMUX block on only) = 13.9°C/W

10.5 Thermal Management Recommendations

In still air and 25°C ambient temperature conditions, the maximum temperature of 106°C + 25°C = 131°C is reached for the ADC block. It is consequently necessary to manage the heat from the AT84AS004 very carefully to avoid permanent damages of the device due to over temperature operation.

In no air cooling conditions, an external heatsink must be placed on top of package. An electrical isolation may be necessary as the top of the package is at $V_{EE} = -5V$ potential.

It is advised to use an external heatsink with intrinsic thermal resistance better than 4°C/Watt when using air at room temperature 20~25°C. At 60°C, the external heatsink should have an intrinsic thermal resistance better than 3°C/Watt. [Figure 10-1](#) provides the outlines of the heat sink used on the AT84AS004-EB evaluation board.

Figure 10-1. AT84AS004-EB Evaluation Board Heat Sink Outlines

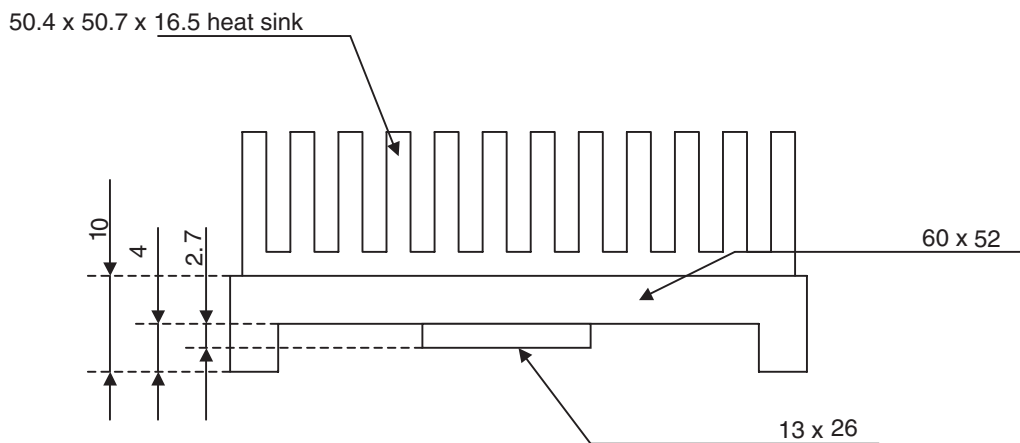

Note: All units are in mm

10.6 Moisture Characteristics

This device is sensitive to the moisture (MSL3 according to JEDEC standard).

Shelf life in sealed bag: 12 months at $<40^{\circ}\text{C}$ and $<90\%$ relative humidity (RH).

After this bag is opened, devices that will be subjected to infrared reflow, vapor-phase reflow, or equivalent processing (peak package body temperature 220°C) must be:

- mounted within 168 hours at factory conditions of $\leq 30^{\circ}\text{C}/60\%$ RH, or
- stored at $\leq 20\%$ RH

Devices require baking, before mounting, if Humidity Indicator is $>20\%$ when read at $23^{\circ}\text{C} \pm 5^{\circ}\text{C}$.

If baking is required, devices may be baked for:

- 192 hours at $40^{\circ}\text{C} + 5^{\circ}\text{C}/-0^{\circ}\text{C}$ and $<5\%$ RH for low temperature device containers, or
- 24 hours at $125^{\circ}\text{C} \pm 5^{\circ}\text{C}$ for high-temperature device containers.

11. Applying the AT84AS004

11.1 Bypassing, Decoupling and Grounding

All power supplies have to be decoupled to ground as close as possible to the signal accesses to the board by $1\ \mu\text{F}$ in parallel to $100\ \text{nF}$.

Figure 11-1. AT84AS004 Power supplies Decoupling and grounding Scheme

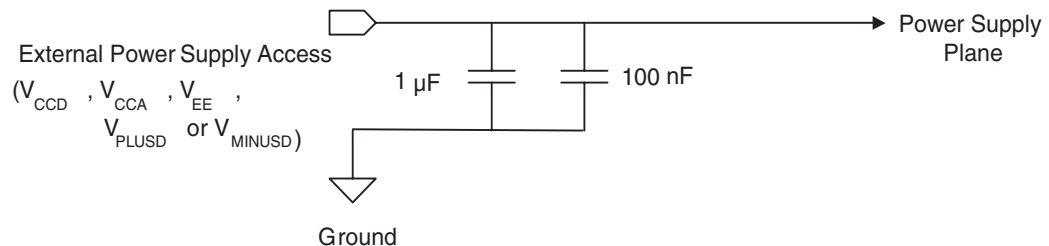

Note: V_{CCD} and V_{CCA} planes should be separated but the two power supplies can be reunited by a strap on the board.

Each group of neighboring power supply pins attributed to the same value should be bypassed with at least one pair of $100\ \text{pF}$ in parallel to $10\ \text{nF}$ capacitors. These capacitors should be placed as close as possible to the power supply package pins.

The minimum required pairs of capacitors by power supply type is:

- 10 for V_{CCA}
- 15 for V_{CCD}
- 11 for V_{EE}
- 22 for V_{PLUSD}
- 3 for V_{MINUSD}

Figure 11-2. AT84AS004 Power Supplies Bypassing Scheme

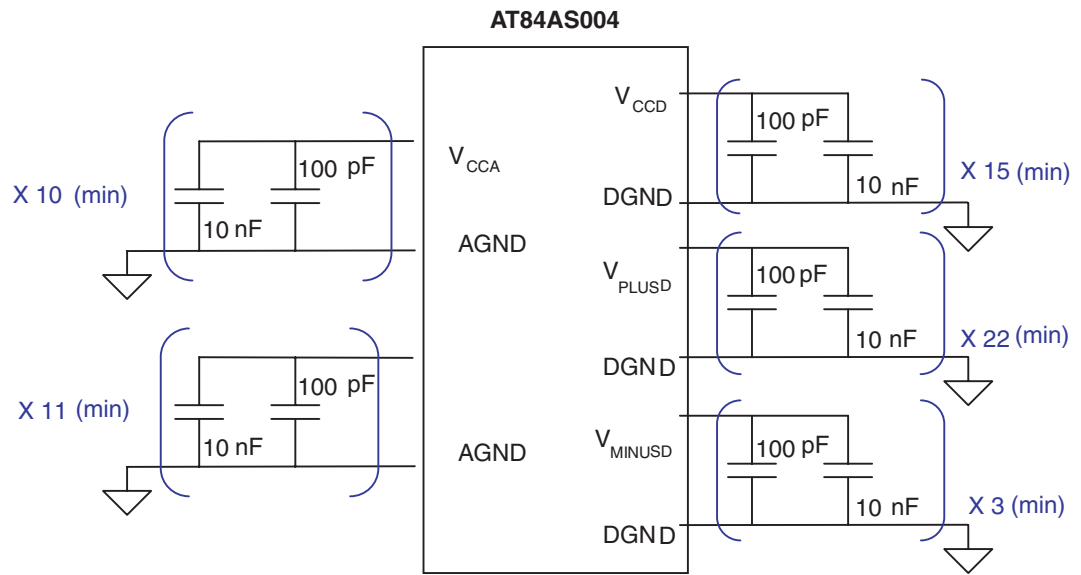

11.2 Analog Input Implementation

Two pins are available for each positive (VIN) and negative (VINN) inputs. It is necessary to terminate one of each input pair by 50Ω to ground as close as possible to the EPGA package pins. This is illustrated in Figure 11-3.

Figure 11-3. AT84AS004 Analog Input Reverse Termination Scheme

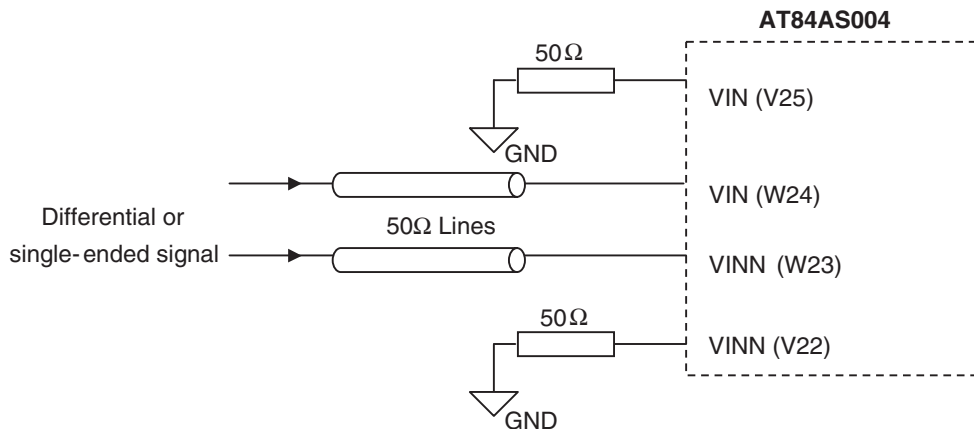

The analog input of the AT84AS004 device can be indifferently entered in single-ended or differential mode.

Figure 11-4. AT84AS004 Analog Input Termination Scheme (Single-ended)

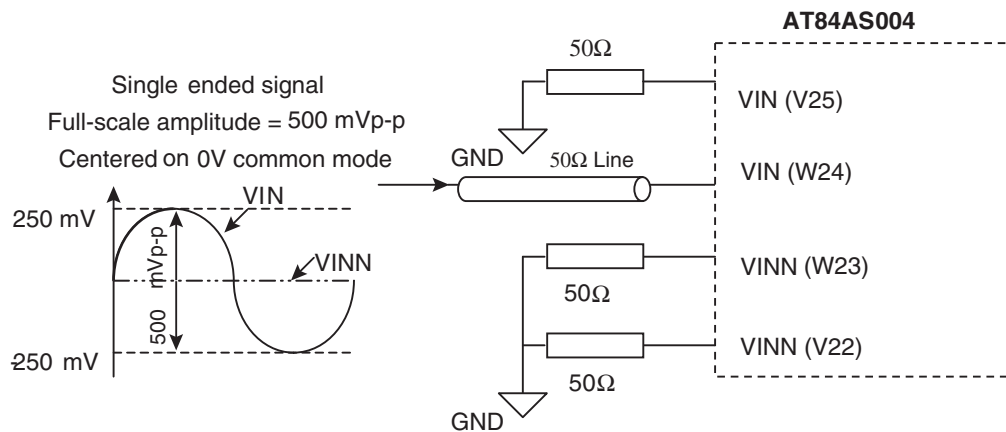

Note: The two 50Ω terminations connected to the two negative inputs (VINN) can be replaced by one 25Ω resistor to ground.

Figure 11-5. AT84AS004 Analog Input Termination Scheme (Differential)

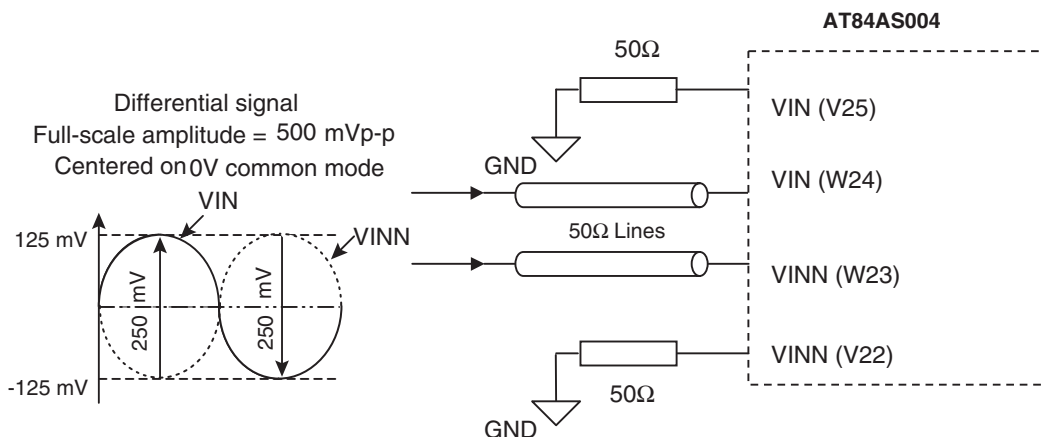

11.3 Clock Input Implementation

The AT84AS004 clock inputs (CLK/CLKN) are designed for either single-ended or differential operation but it is recommended to drive the clock differentially to optimize the device's performances at high frequencies. No external 50Ω termination are required for the clock inputs (CLK/CLKN) as they are already on-chip terminated by two 50Ω resistors connected to ground via an on-chip 40 pF capacitor.

The AT84AS004 input clock can be used in either DC coupled (0V common mode) or AC coupled (ECL, LVDS for example) mode. It is recommended to use a differential sinewave signal (0 dBm or 894 mVp-p differential) centered on 0V common mode to drive the clock signals. A balun (with Sqrt(2) ratio) may then be necessary to convert the single-ended clock signal to a differential clock signal.

Note: If the clock frequency is fixed, then it is recommended to narrow-band filter the clock signal in order to minimize its jitter and the integrated noise over the band of interest.

Figure 11-6. AT84AS004 Clock Input Termination Scheme (Single-ended)

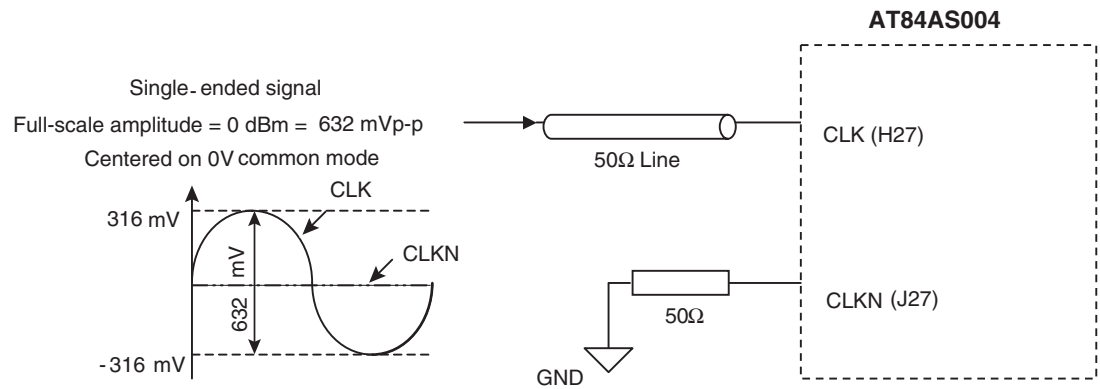
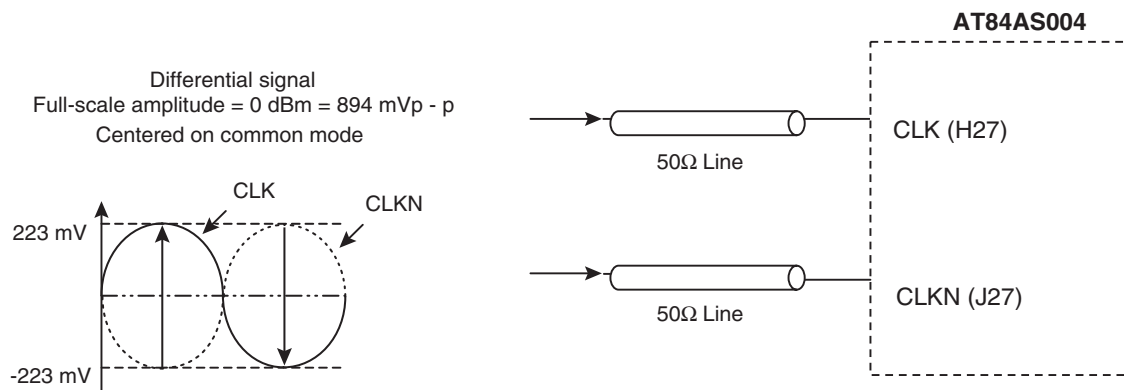

Figure 11-7. AT84AS004 Clock Input Recommended Termination Scheme (Differential)



11.4 LVDS Input Implementation

The DAI/DAIN input data of the standalone delay cell is LVDS compatible. It is $2 \times 50\Omega$ differentially on-chip terminated as described in Figure 11-8.

Figure 11-8. AT84AS004 LVDS Input (DAI/DAIN) Termination Scheme

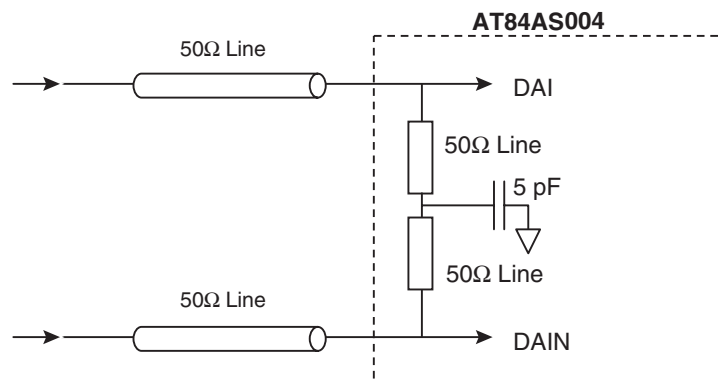

11.5 LVDS Output Implementation

The data (Ai/AiN...Di/DiN, AOR/AORN...DOR/DORN and DAO/DAON) and clock outputs (DR/DRN) are LVDS compatible. They have to be 100Ω differentially terminated as described in [Figure 11-9](#).

Figure 11-9. AT84AS004 LVDS Output Termination Scheme

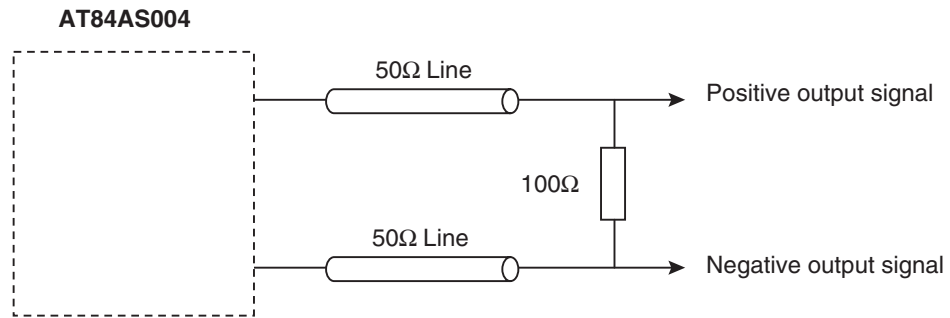

11.6 DRRB and ASYNCRST Implementation

The DRRB and ASYNCRST are required to start the device properly. DRRB is active at low level while ASYNCRST is active at high level.

As it is recommended to apply both reset signals simultaneously, one possible solution is to use a differential driver so that DRRB and ASYNCRST are generated as the two signals of a differential pair. This would allow for both the simultaneous application of the signals to the device a simple way to drive both signals. An example is provided below, [Figure 11-10](#).

Figure 11-10. AT84AS004 DRRB and ASYNCRST Driver Scheme

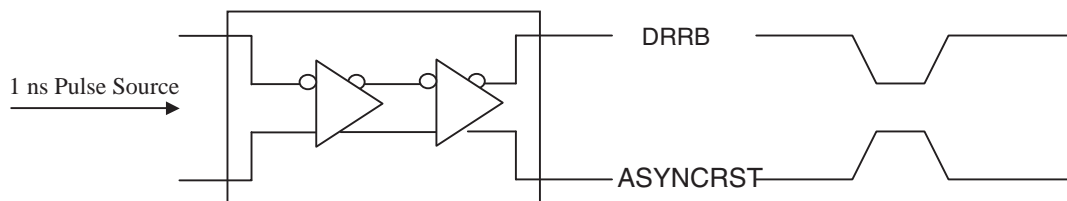

Please refer to the AT84AS004 “Reset Implementation Application Note” for more information.

12. Package Information

Figure 12-1. .EBGA317 Package Outline

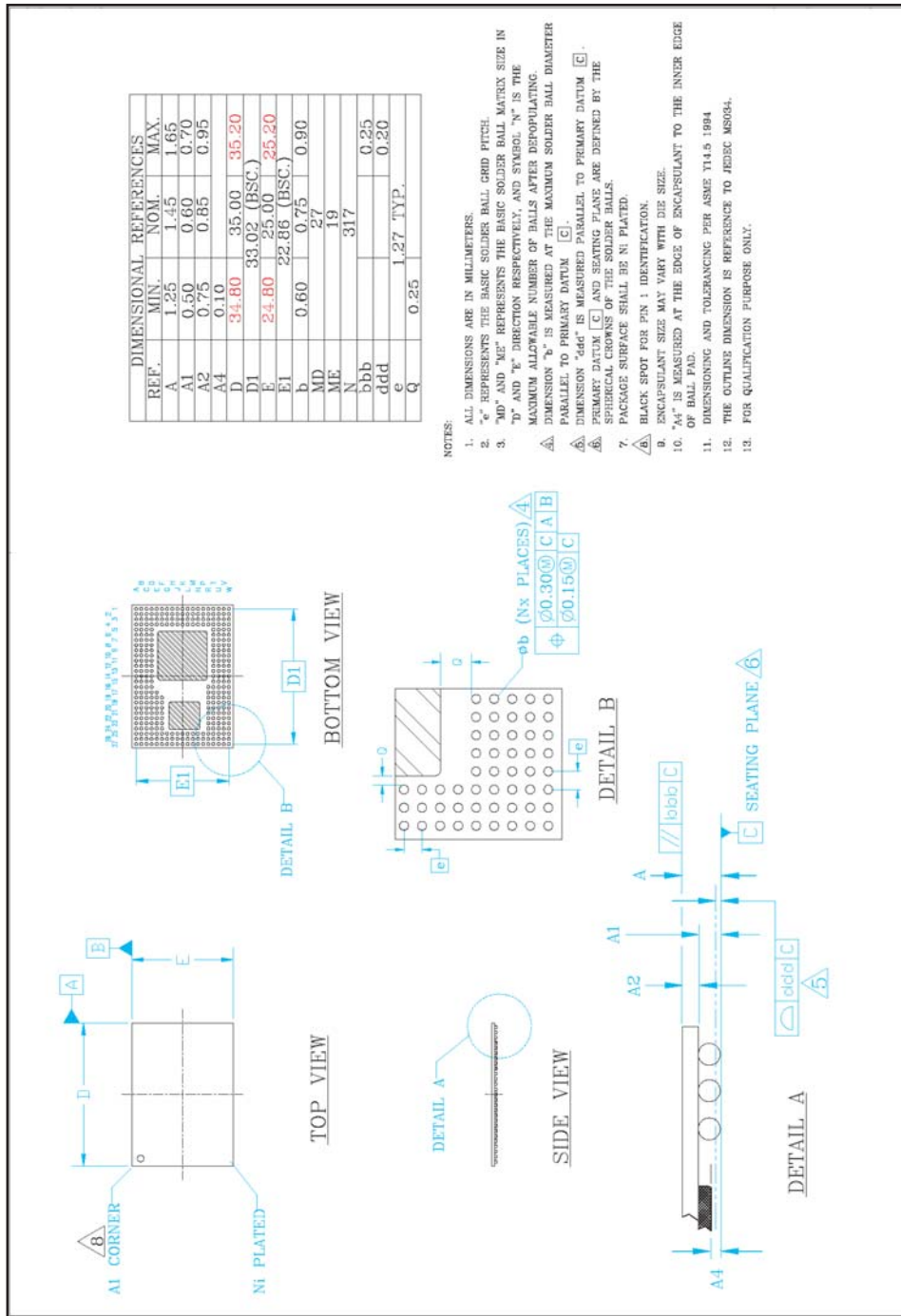

Note: The two pads at the bottom of the EBGA package are the dice moldings and should not be soldered to the board.

13. Ordering Information

Table 13-1. Ordering Information

Part Number	Package	Temperature Range	Screening	Comments
AT84AS004CTP	EBGA 317	Commercial <i>C</i> $0^{\circ}\text{C} < T_{\text{amb}}$ $T_{\text{J}} < 90^{\circ}\text{C}$	Standard	
AT84AS004VTP	EBGA 317	Industrial <i>V</i> $-40^{\circ}\text{C} < T_{\text{amb}}$ $T_{\text{J}} < 110^{\circ}\text{C}$	Standard	
AT84XAS004TPY	EBGA 317 RoHS	Ambient	Prototype	For availability please contact your local sales office
AT84AS004CTPY	EBGA 317 RoHS	Commercial <i>C</i> $0^{\circ}\text{C} < T_{\text{amb}}$ $T_{\text{J}} < 90^{\circ}\text{C}$	Standard	For availability please contact your local sales office
AT84AS004VTPY	EBGA 317 RoHS	Industrial <i>V</i> $-40^{\circ}\text{C} < T_{\text{amb}}$ $T_{\text{J}} < 110^{\circ}\text{C}$	Standard	For availability please contact your local sales office
AT84AS004TP-EB	EBGA 317	Ambient	Prototype	Evaluation kit

Table of Contents

1	Description	2
2	Block Diagram	2
3	Functional Description	3
4	Specifications	5
4.1	Absolute Maximum Ratings	5
4.2	Electrical Operating Characteristics	7
4.3	Explanation of Test Levels	12
4.4	Digital Coding	13
5	Characterization Results	14
5.1	Nominal Conditions	14
5.2	Full Power Input Bandwidth	14
5.3	VSWR Versus Input Frequency	15
5.4	Step Response	15
5.5	Dynamic Performance Versus Sampling Frequency	16
5.6	Dynamic Performance Versus Input Frequency	16
5.7	Signal Spectrum	17
5.8	Dynamic Performance Sensitivity Versus Temperature and Power Supply	18
5.9	Dual Tone Performance	19
5.10	NPR Performance	20
6	Pin Description	21
7	Main Features	25
7.1	Reset	25
7.2	Control Signal Settings	27
7.3	Programmable DMUX Ratio	29
7.4	Output Mode (STAGG)	29
7.5	Additional Bit	31
7.6	Output Clock Type Selection	32
7.7	Power Reduction Mode (SLEEP)	32
7.8	Standalone Delay Cell	32
7.9	Clock input Delay Cell	33
7.10	Built-In Self Test	33
7.11	ADC Die Junction Temperature Monitoring	33

7.12	Pattern Generator Function	35
7.13	ADC Gain Control	35
7.14	Sampling Delay Adjust	35
8	<i>Equivalent Input/Output Schematics</i>	36
8.1	Equivalent Analog Input Circuit and ESD Protection	36
8.2	Equivalent Clock Input Circuit and ESD Protection	36
8.3	Equivalent Data/Clock Output Buffer Circuit and ESD Protection	37
8.4	Standalone Delay Cell Data Input (DAI/DAIN) Buffer Circuit and ESD Protection	37
8.5	Delay Cell (DACTRL/DACTRLN and CLKCTRL/CLKCTRLN) Control Input Schematic and ESD Protection	38
8.6	DRRB Equivalent Input Schematic and ESD Protection	38
8.7	ASYNCRST Equivalent Input Schematic and ESD Protection	39
8.8	ADC Gain Adjust Equivalent Input Circuits and ESD Protection	39
8.9	B/GB and PGEB Equivalent Input Schematics and ESD Protection	40
8.10	Control Signals Input Buffers and ESD Protection	40
9	<i>Definitions of Terms</i>	41
10	<i>Thermal and Moisture Characteristics</i>	43
10.1	Thermal Resistance from Junction To Bottom of Balls	43
10.2	Thermal Resistance from Junction To Top of Case	43
10.3	Thermal Resistance from Junction To Board	43
10.4	Thermal Resistance from Junction To Ambient	44
10.5	Thermal Management Recommendations	44
10.6	Moisture Characteristics	45
11	<i>Applying the AT84AS004</i>	45
11.1	Bypassing, Decoupling and Grounding	45
11.2	Analog Input Implementation	46
11.3	Clock Input Implementation	47
11.4	LVDS Input Implementation	48
11.5	LVDS Output Implementation	49
11.6	DRRB and ASYNCRST Implementation	49
12	<i>Package Information</i>	50
13	<i>Ordering Information</i>	51



How to reach us

Home page: www.e2v.com

Sales Office:

Northern Europe

e2v ltd

106 Waterhouse Lane
Chelmsford
Essex CM1 2QU
England
Tel: +44 (0)1245 493493
Fax: +44 (0)1245 492492
E-Mail: enquiries@e2v.com

Southern Europe

e2v sas

16 Burospace
F-91572 Bièvres
Cedex
France
Tel: +33 (0) 16019 5500
Fax: +33 (0) 16019 5529
E-Mail: enquiries-fr@e2v.com

Germany and Austria

e2v gmbh

Industriestraße 29
82194 Gröbenzell
Germany
Tel: +49 (0) 8142 41057-0
Fax: +49 (0) 8142 284547
E-Mail: enquiries-de@e2v.com

Americas

e2v inc.

4 Westchester Plaza
Elmsford
NY 10523-1482
USA
Tel: +1 (914) 592 6050 or
1-800-342-5338,
Fax: +1 (914) 592-5148
E-Mail: enquiries-na@e2v.com

Asia Pacific

e2v

Bank of China Tower
30th floor office 7
1 Garden Rd Central
Hong Kong
Tel: +852 2251 8227/8/9
Fax: +852 2251 8238
E-Mail: enquiries-hk@e2v.com

Product Contact:

e2v

Avenue de Rochepleine
BP 123 - 38521 Saint-Egrève Cedex
France
Tel: +33 (0)4 76 58 30 00
Hotline:
hotline-bdc@e2v.com

Whilst e2v has taken care to ensure the accuracy of the information contained herein it accepts no responsibility for the consequences of any use thereof and also reserves the right to change the specification of goods without notice. e2v accepts no liability beyond that set out in its standard conditions of sale in respect of infringement of third party patents arising from the use of tubes or other devices in accordance with information contained herein.